

Dear Pontiac Enthusiast:

Thank you for choosing Ames Performance Engineering as your leading source for Pontiac restoration and performance parts. Our goal is simple; to supply you, the customer, with the best available products always at fair prices backed by the best customer service in the industry.

For 34 years Ames Performance Engineering has been doing just that. We are active in the Pontiac industry by attending 13 major swap meets with our 35-foot vending trailer. Ames sponsors over 75 Pontiac club shows and events and is the principal sponsor for all aspects of the Ames Performance Pontiac Nationals at Norwalk, Ohio. We also sponsor several venues at the GTOAA Nationals and POCI Nationals.

Thank you again for choosing Ames Performance Engineering as your supplier of Pontiac restoration parts. Your comments are important to us in our ongoing effort to ensure that your experience with us is satisfactory. Therefore, if you have any suggestions or concerns please do not hesitate to contact us.

Thank You,
The Ames Team

Miscellaneous.....	4-9
Literature	10-13
Interior.....	14-47
Front End Trim	48-53
Front Fender Trim	54-56
Hood Components	57-60
Door Components.....	61-77
Windshield and Rear Window	78-81
Convertible/T- Top	82-86
Rear 1/4 Trim.....	87-92
Trunk Components.....	93-99
Rear End Trim.....	100-108
Electrical Related	109-119
Engine Components.....	120-158
Engine Compartment	159-170
Transmission, Clutch and Brake	171-198
Suspension & Steering.....	199-209
Wheels & Tires.....	210-214
Decals	215-218

WANTED

Low Mileage, Low Production

We continue to add Pontiac muscle cars to the collection. If you know of a very low mileage original car or low production in any condition please call 800-421-2637.

Finder's fee paid.

GLOSSARY OF ABBREVIATIONS

AC	Air Conditioning	GM	Factory Part (General Motors)	RE	Reproduction Part
AP	After Product	HD	Heavy Duty	RH	Passenger Side (Right Hand Side)
AS	Air Suspension	HO	High Output	RP	Replacement Part
AT	Auto Transmission	ID	Inside Diameter	Sedan	Sport Coupe w/post
ATC	Auto Temperature Control	LH	Drivers Side (Left Hand Side)	SW	Station Wagon
APE	Ames Product	MT	Manual Transmission	TI	Transistorized Ignition
HT	Hardtop Coupe (no post)	NOS	New Old Stock (Factory Part that's no longer available from GM)	TH350	Turbo-350 Transmission
CVT	Convertible	OD	Outside Diameter	TH400	Turbo-400 Transmission
Disc	Discontinued	OEM	Original Equipment Manufacturer		
Inq	Inquire				
DB	Disc Brakes				

Welcome To Ames Performance Engineering

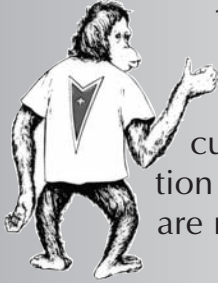

Thank you for requesting our newest Fullsize Catalog. Ames Performance Engineering sells only Pontiac parts and is in its 34th year of supplying enthusiasts worldwide. During this time we have established a reputation with our customers for prompt service and the finest quality product available. This attention to quality is especially evident in our reproduction items, many more of which are now being made in our own shop. As in the past we will critique our products in order to inform our customers of the quality of each reproduction.

Ordering Methods

By Phone

1-800-421-2637

Our sales representative are available to take orders or to answer any questions you may have.

***M-W 8:00am - 9:00pm est**
T-F 8:00am - 6:00pm est
Sat 9:00am - 3:00pm est

* Limited staff between 6-9pm and 9-3 Sat.

For international calls please dial:

603-363-7000

By Internet

Check out our secure website to order 24hours per day
7 days per week.

www.amesperf.com

By Fax

1-603-363-7007

Our FAX machine is available 24 hours, 7 days per week.
Faxed orders are typically processed the same day they
are received.

By Mail

Simply fill out one of our order forms from the back of the
catalog and mail it to us with your payment enclosed. If
you have any questions or need additional order forms,
please call our sales department toll free.

Ames Performance Engineering
PO Box 572
10 Pontiac Drive
Spofford, NH 03462

Methods of Payment

Credit Cards



We accept Mastercard, Visa, Discover Card and
American Express. When placing an order please
make sure you give us the name on the card and the
correct billing address.

Money Orders and Checks

Cashier's Checks, Money Orders and Personal Checks
are accepted. Personal checks will be held for 14 days
pending check clearance.

**An Ames Performance Gift Certificate Is
Perfect For That Particular Enthusiast
Who Has Everything.**

Please Inquire.



Pricing Information

Discounts

3% on orders over \$500.00 with Credit Card.
5% on orders over \$500.00 with check or money order.
8% on orders over \$1000.00 with Credit Card.
10% on orders over \$1000.00 with check or money order.

NOTE: Discounts do not apply to shipping charges and
specially marked items. Also, discounts are applied to
individual order only.

Prices

We will maintain the prices in this catalog as long as pos-
sible. However, we reserve the right to make price
changes whenever necessary. Prices charged shall be
those prevailing at time of shipment. Items may be dis-
continued at any time.

NO RETAIL OUTLET — SALES BY PHONE, MAIL, INTERNET AND AT SHOWS ONLY

Shipping

Shipping charges:

\$10 - \$50	\$ 9.00
\$50.01 - \$100	\$15.00
\$100.01 - \$250 ...	\$18.00
\$250.01 - \$500 ..	\$22.00
\$500.01 +	\$29.00



Additional shipping charges may be added as noted in the catalog.

COD

There is an additional \$10.00 charge per box for COD shipments. These package(s) must be shipped to a location where someone is present during normal business hours to accept and pay for the package. If an order does not get accepted we are obligated to pay the shipping both ways. These charges will be passed on to the customer and you will not be able to place another order until the shipping charges are cleared up. COD shipments cannot be shipped by air. Carriers will not accept cash or personal / company checks.

Air Shipments

There are no surcharges for air shipments. However, UPS expedited charges will be applied to your order. Next Day Air, 2nd Day Air, 3 Day select and Next Day Saturday delivery is available.

Truck Shipment

Certain items, because of their size or weight, must be shipped via common carrier. All items shipped by truck need to be shipped to a commercial address. **These shipments must be inspected for damage before being signed for.** Once signed for the customer assumes responsibility of product. COD is not an option on truck freight orders.

Foreign Shipments

Foreign orders will be shipped via UPS Expedited or USPS and you will be billed for the actual shipping charge. All foreign orders must be prepaid with credit card or certified US funds. Taxes and duties are the responsibility of the receiving party.

Show Deliveries

Save money by having Ames Performance bring your parts to you at one of the many shows we attend throughout the year. As always, show deliveries are free of any handling or shipping charges.



Customer Service

Service

Phone, mail-orders and internet orders will be processed and shipped within 24 hours except during weekends, shows or in backorder situations. During 2009 our large in-house inventory allowed us to ship over 90% of all orders within that deadline.

Returns & Damages

All parts in this catalog are sold with a satisfaction guaranteed policy. **Please examine your order immediately. All shortages, incorrect items, and damages must be reported within 15 days.** If the package was damaged during shipment, save the merchandise and packaging and notify us immediately for instructions.

To return an item, please contact us for instructions and a return authorization number. If Ames is responsible for the incorrect shipment, we will reimburse the customer for their return shipping charges, but under no circumstances will Ames pay for additional charges incurred by using packaging services, air shipping or accept COD shipments. For your protection, send the package via UPS or insured Parcel Post, saving the receipt until you hear from us. Special ordered items and items more than 90 days old may be subject to a restocking fee.

Backorders

Ames Performance Engineering maintains an inventory that provides the lowest backorder rate in the industry. However, on some occasions we may be out of stock on certain items. All backorders will be tracked by our computers and flagged when your backorder can be filled. We accept responsibility for shipping charges on backordered items with the exception of additional 'oversize' charges or truck freight items. Most back-ordered items will not be charged until they are shipped.

Warranty Policy

Ames Performance Engineering honors **manufacturer warranties** on all products that we sell. Most manufacturers have a limited warranty on their products that covers replacement cost of the product only. **Labor and shipping costs are not included in the warranty of any product.** Labor and shipping costs on warranty items, unfortunately, will be the responsibility of the consumer or installer involved. This is common practice and should be understood by our customers prior to purchasing product from Ames Performance.

Ames Performance Engineering

“The Nation’s Largest Supplier of Pontiac Restoration Parts”

MISCELLANEOUS

CAR COVERS & JACKETS



- PV101 1955-56 Flannel-Lined Car Cover w/Storage Bag\$225.00/ea.
- PV103 1957 Flannel-Lined Car Cover w/Storage Bag225.00/ea.
- PV105 1958 Flannel-Lined Car Cover w/Storage BagInquire
- PV107 1959-60 Flannel-Lined Car Cover w/Storage BagInquire
- PV109 1961-63 Flannel-Lined Car Cover w/Storage Bag225.00/ea.
- PV111 1964-70 Flannel-Lined Car Cover w/Storage Bag Catalina and '64-'68 GP225.00/ea.
- PV112 1964-76 Flannel-Lined Car Cover w/Storage Bag - Bonneville225.00/ea.
- PV113 1971-76 Flannel-Lined Car Cover w/Storage Bag - Catalina225.00/ea.
- PV115 1969-72 Flannel-Lined Car Cover w/Storage Bag - GP225.00/ea.
- PV115A 1973-77 Flannel-Lined Car Cover w/Storage Bag - GP225.00/ea.
- PV120 All Years Anti-Theft Steel Cable w/Lock12.00/ea.

Our new line of car covers offers the ultimate protection for your Pontiac's finish. Pre-shrunk 100% cotton outer with flannel lining protects from dust, scratches and dents while allowing moisture to escape. Of all the car covers we've seen to date, these flannel-lined covers far exceed the quality of unlined cotton covers.

Note: These covers are recommended for indoor use only. At the time of catalog printing several patterns for the above years have not been finalized. Please call to see if your year and body style are available.

- PV125 1964-70 Technalon Car Cover - Catalina and '64-'68 GP215.00/ea.
- PV125A 1964-76 Technalon Car Cover - Bonneville245.00/ea.
- PV126 1971-76 Technalon Car Cover - Catalina215.00/ea.
- PV127 1969-72 Technalon Car Cover - GP219.00/ea.
- PV127A 1973-77 Technalon Car Cover - GP219.00/ea.

We do not recommend outdoor storage of vehicles; however, when it is necessary, Technalon covers will protect your Pontiac's finish from the elements. They are made from the water resistant "Evolution 4" material which maintains complete breathability. One of the thickest covers available, it protects against scratches and minor dents as well.

- PV128 1955-77 Car Jacket (AP)299.00/ea.

Used in conjunction with our flannel-lined car cover to protect from scratching, this polyethylene car jacket will protect your car from dust & moisture in long term storage situations. Includes 5 lbs. of desiccant material in 8 oz. packages, owners manual, locks, and an antenna guard.

Add \$7.00 oversize fee to standard shipping for car jackets.



FENDER COVERS



PV180G

- PV180G Ames Performance Fender Cover..... Disc..
- PV180J "We Build Excitement" Fender Cover (AP)\$25.00/ea.



PV180J



PV180L

- PV180L "Heartbeat Stops Here" Fender Cover (AP) 20.00/ea.

With this fender cover you will be able to protect your finely restored Pontiac and irritate a Chevy owner all at the same time.



PV180P

- PV180P "Pontiac Racing" Fender Cover (AP) Inquire
- PV180R Plain Fender Cover (AP)..... 13.00/ea.



PV180R

AFTERMARKET DECALS



PV178

- PV178 8" Pontiac Parts Decal (AP) \$5.00/ea



PV178A

- PV178A 10" Authorized Pontiac Indian Head Service Decal (AP) 6.50/ea.



PV178D

- PV178D Genuine Pontiac Parts Decal (AP) 5.00/ea.
- PV178F Pontiac Factory Engineered Parts Decal (AP) 4.00/ea.



POR 15 RUST PREVENTION PRODUCTS

M I S C E L L A N E O U S



PV138

PV139

PV141

PV141A

PV141C

PV142

PV143

PV144

PV146

After several years of using POR 15 with excellent results, we have started to carry their rust-preventive products. By using their 4-step process rust will be permanently stopped.

Step 1 - Degrease & Clean Surface

PV138 POR 15 Marine Clean w/ Spray Bottle (AP) \$20.00/gal.
This environmentally safe cleaner degreases and leaves a residue-free surface. It can be diluted with water up to 10 times its volume. Excellent cleaner!

Step 2 - Neutralize Rust; Etch Metal

PV139 POR 15 Metal Prep With Spray Bottle (AP) 30.00/gal.
Also environmentally safe, this product will etch aluminum and other metals while leaving a zinc phosphate film that will enhance the chemical bonding of POR 15.

Step 3 - Rust Preventive Paint

PV141 POR 15 Black Gloss Coating (AP)..... 42.00/qt.
PV141A POR 15 Black Semi-Gloss Coating (AP) 42.00/qt.

Available in either gloss or semi-gloss black, these coatings can be applied directly over rust and seal it permanently. Por 15 cures by absorbing moisture from the atmosphere, completely sealing the rust and providing a chip-resistant finish.

PV141C POR 15 Solvent (AP) 11.00/qt.
PV141C is used in conjunction with POR15 coatings to dilute for spraying.

PV142 POR 15 Super Starter Kit (AP) 18.00/ea.
For small jobs or just to try the rust-preventive system, use this starter kit. Comes with 1/2 pint of Marine Clean, 1/2 Pint Metal Prep, screw top jar of gloss black POR 15 coating (enough for 12 square feet), 2 wooden handle brushes and a pair of rubber gloves.

Step 4 - Top Coats

PV143 POR 15 Chassis Coat (AP) 45.00/qt.
PV143A POR 15 Chassis Coat 14 oz. Aerosol (AP)..... 20.00/ea.

Use as a UV-resistant top coat or as an original-style frame and suspension finish. It resists scratches and abrasions extremely well which makes it an excellent finish for frame and suspension components.

PV147 POR 15 Metal Mask, 8 oz. (AP) 15.00/ea.
PV147A POR 15 Metal Mask, Quart (AP) 44.00/ea.
PV141C POR 15 Solvent 11.00/qt.
PV141C is used in conjunction with POR 15 coatings for spraying.

POR 15® Primers

PV144 POR 15 Tie Coat Primer (AP) \$27.00/qt.
Can be applied to any POR 15 surface, old or new, as an interlocking sandable polyurethane primer. Works well with almost any paint, including lacquers, enamels, and two-part component finishes.

PV145 POR 15 Self Etching Primer, 8oz Spray Can (AP) 23.00/ea.
PV145A POR 15 Self Etching Primer, Quart (AP) 44.00/qt.
A perfect solution for painting over the top of cured POR-15. This high-tech coating will gently etch POR-15, preparing the surface for bonding with the paint of your choice. This is not a high-build primer. Use the Tie-Coat Primer for your primer/filler applications.

POR 15® Kits

PV142 POR 15 Super Starter Kit (AP) 18.00/ea.
For small jobs or just to try the rust-preventive system, use this starter kit. Comes with 1/2 pint of Marine Clean, 1/2 Pint Metal Prep, screw top jar of gloss black POR 15 coating (enough for 12 square feet), 2 wooden handle brushes and a pair of rubber gloves.

PV146 POR 15 Fuel Tank Sealer (AP)..... 35.00/qt.
Impervious to all fuels including alcohol, this environmentally safe sealer is meant to be used in conjunction with other POR 15 components (marine clean and metal prep). Stops rust and corrosion, seals pinholes and seams, remains flexible and will seal a 25-gallon tank.

PV148 POR 15 Fuel Tank Repair Kit(AP) 69.00/kit
PV148 includes enough materials to repair most gas tanks with minor leaks due to cracked seams or pinholes with the following products: (2) quarts of Marine Clean®, (1) quart Metal Ready®, (1) quart of fuel tank sealer, and (1) quart of fuel stabilizer.

PA342TV POR 15 Steering Wheel Restoration Kit (AP)..... 89.00/kit
Contains all materials needed to refurbish cracked or broken wheels to show quality. Interior color paint is not included.

GM CAR CARE



PV135

PV135 GM Car Care Bucket Kit (AP)..... 109.00/kit
PV135 includes the following GM car care products: 3 1/2 gallon wash bucket, terry towels (2), chamois cloths (2), applicator pads, wash mitt, glass cleaner, finish enhancer, tire shine, cleaner-wax, wash-wax, and swirl remover.

PV815 Chrome Cleaner, 16 oz 7.00/ea.
Complex blend of pumice, oil, water and silicone.



PV168 3/8" Double-Ended Spotweld Cutter 19.50/ea.
PV168 is a must for cutting out original factory spotwelds.
PV168A Replacement Cutter Bits for PV168 (Pack of 3).. 19.50/set

MOTHERS® CAR CARE COMPONENTS



PV131

PV131 Mother's Mag and Aluminum Wheel Polish, 5 oz. Jar(AP)..... \$7.00/ea.

The Mothers® secret formula balances a brilliant shine with easy use for aluminum wheels and parts, brass, alloys and accessories. Application is just a matter of a clean cloth and a little elbow grease. Mothers® Mag & Aluminum polish is strong enough to put a shine to the most neglected metals and gentle enough to use on a regular basis.



PV133

PV133 Mother's 100% Carnauba California Gold Wax, 12 oz. Jar (AP)..... 22.00/ea.

Mothers® Pure Carnauba Wax is made with the finest Brazilian #1 yellow carnauba for superior shine and protection. It is non-abrasive, so use it as often as you like. You can apply more than one coat to keep your efforts well protected.



PV134ST

PV134ST Mother's Showtime Instant Detailer, 24 oz. \$12.00/ea.

Treat your paint to a Showtime® sparkle that's wet and striking. Whether you want to clear a layer of dust or prepare for the judges, use Showtime® Instant Detailer. Its unique formula will clean off fingerprints, smudges and dust, and hide minor imperfections and spider-webbing. Showtime® is designed with color enhancers and shine fortifiers, ready whenever you need your ride to look freshly detailed.



PV134WM

PV134WM Mother's Wheel Mist, 24 oz. 9.00/ea.

When your chrome is dirty, hazed and oxidized and corrosion is setting in, it's time for the big gun. Wheel Mist® Chrome/Wire is the original, powerful one-step that works on chrome wheels, chrome bumpers and roughcast aluminum. Spray on and hose off—this is the quickest way to the sharpest shine your chrome wheels and bumpers have ever seen. Overheated brake dust, surface rust, ground in dirt and oxidation can't evade this high impact cleaner.



PV134CW



PV134CWX



PV134GC

PV134CW Mother's Carwash Concentrate, 32 oz. 9.00/ea.

Mother's® Car Wash is strong enough to wash away dirt, road film, bugs, bird droppings, airborne pollutants and other grime, without removing wax or dulling the paint. pH balanced, super-sudsy and also resists water spotting.

PV134CWX Mother's Cleaner Wax, 16 oz. 10.50/ea.

Cleaner Wax is formulated to clean and protect in just one application. Uses the same Brazilian #1 yellow carnauba as FV133, combined with a light polish that will smooth minor flaws and make your paint snap.

PV134GC Mother's Glass Cleaner, 24 oz. 7.50/ea.

Great on all automotive glass, headlight lenses, mirrors and even chrome, this glass cleaner doesn't leave streaks. Professional strength formula is safe and ammonia-free.



PV134 Mother's Complete Car Care Kit (AP) 49.00/kit

PV134 includes the following Mothers® car care products: 4 gallon wash bucket, wash cloth, 16oz. car wash, 22oz. wheel mist, 16oz. glass cleaner, 8oz. scratch remover, 16oz. carnauba cleaner-wax, 16oz. Showtime® instant detailer, and a 16oz. interior protectant. Excellent for gift-giving.



PV134PR



PV134SR

PV134PR Mother's Preserved Protectant, 16 oz. 8.50/ea.

Preserves and protects for 30 days! Mothers® Protectant is a penetrating UV blocker, effective on rubber, vinyl, plastic and fiberglass. Constructed to recondition and maintain the original condition and appearance of dashboards, bumpers, trim, tires and more. Protectant isn't an oily surface-coating film. It's an ozone and smog resisting, UV shielding penetrant — a preservation agent that works on just about any uncoated plastic or rubber.

PV134SR Mother's Scratch Remover, 8 oz. 9.00/ea.

There are areas of your paint's finish that see more abuse than others: on the edge of doors and the trunk lid, around the door handles, keyholes, at the hood latch, etc. What you need is a scratch remover. Mothers® Scratch Remover works on any sort of paint, any sort of finish, to help restore high mileage paint and remove surface scratches. This is a true polish—be sure to chase it with the standard regiment of waxing to properly seal and protect.

DUSTERS AND WATER BLADES



PV332

PV332 California Water Blade 23.00/ea.

Removes 90% of standing water on any vehicle's surface without scratching or streaking. The water blade is made from medical grade silicone, producing 15 times less friction than a terrycloth towel, and won't retain dirt or other materials that will scratch. The Water Blade removes water with a single stroke, even on contoured surfaces.



PV333

PV333 California Car Duster (AP)..... 19.00/ea.

PV333A Mini Duster (AP) 10.00/ea.

These dusters have specially treated cotton fibers that will lift off dust without scratching painted surfaces. Their baked-in paraffin wax fibers will actually work better the dirtier they get. After years of wiping with wet towels and worrying about scratching, we now use the California Car Dusters exclusively.



DYNAMAT®



Dynamat®, the industry leader in sound deadening and heat dissipating materials, provides an array of products that can make your Pontiac comfortable on the inside despite what it may sound like on the outside. We all like that unique throaty rumble of our Pontiac V8's, and Dynamat® makes it possible to have a conversation with our passengers or listen to the radio as well.

- PV129AB** Dynamat® Xtreme Bulk Pak..... \$250.00/kit
PV129AB contains 9 - 18"X32" sheets of Dynamat® Xtreme for lining all areas including underside and vertical applications.
- PV129AJ** Dynamat® Hoodliner..... 70.00/ea.
PV129AJ contains 1 - 32"X54" sheet of Dynamat® Hoodliner.
- PV129AN** Dynamat® Xtreme Door Kit 90.00/kit
PV129AN contains 4 - 11.5"X32" sheet of Dynamat® Xtreme for lining doors.

- PV129AT** Dynamat® Dynaliner \$45.00/ea.
Dynaliner is an added layer of protection to be used with Dynamat®. PV129AT contains 1 - 32"X54" sheet 1/8" thick. Also available in 1/4" & 1/2". Please inquire
- PV129AV** Dynamat® 1 1/8" Roller Tool 9.00/ea.
This economy series 1 1/8" wooden roller tool helps with installation of Dynamat material.
- PV129AW** Dynamat® 1 7/8" Roller Tool 16.00/ea.
This professional series 1 7/8" rubber roller tool helps with installation of Dynamat material.

APPAREL



FRONT



BACK

- PV195B** Ames Performance T-Shirts..... 15.00/ea.
PV195B has the above 3 1/2" X 2 5/8" logo on the left breast with a larger image of Harry on the back.. Colors and sizes available: black, gray and navy blue. Comes in SM, ME, LG, XL, & XXL.



PV196

PV197

- PV196** Hurst '60's Floorshift T-Shirt..... 15.00/ea.
- PV197** Hurst Competition Plus T-Shirt..... 15.00/ea.
colors and sizes available: dk.blue, red, & lt.gray. Comes in SM, ME, LG, XL, & XXL.



PV198

PV199

- PV198** Hurst Warning T-Shirt 15.00/ea.
- PV199** Hurst Beware T-Shirt 15.00/ea.
colors and sizes available: dk.blue, red, & lt.gray. Comes in SM, ME, LG, XL, & XXL.

HATS & KEY CHAINS



PV200

- PV200** Pontiac Hot Hat, Khaki or Black 11.00/ea.
Please specify color when ordering.



PV201

- PV201** Pontiac Racing Hot Hat, Khaki or Black 11.00/ea.
Please specify color when ordering.



PV203A



PV203B



PV203C

- PV203A** "Pontiac" Key Ring 4.00/ea.
- PV203B** "Catalina 2+2" Key Ring 4.00/ea.
- PV203C** "Grand Prix" Key Ring 4.00/ea.

POSTERS



PV213

PV213 20" by 24" Scene of the Sixties Full-Color Poster(APE) \$5.00/ea.

This Poster depicts a stoplight scene featuring a '64 GTO, a '67 GTO, a '67 Shelby GT 350 and a '63 Corvette Coupe

PV218 20" x 26" "Traveler in Time" Full-Color Poster (APE) 5.00/ea.

PV218 Illustrates superb Airbrush work.



PV218

CLOCKS



PV324

PV324 "Pontiac Motor Division" Center Cap Clock (APE) \$49.00/ea.

These clocks use center caps that do not meet our first quality standards for PT140 8-lug center caps. They come complete with quartz works and hands - AA battery not included.

PV325 Gr-rrr! License Plate Clock (AP)..... 16.00/ea.

PV326 Pontiac License Plate Clock (AP) 16.00/ea.

PV327 "We Build Excitement" License Plate Clock White or Black (AP) 17.00/ea.

PV328 "Tin Indian" License Plate Clock (AP)..... 17.00/ea.

PV328B "Grand Prix" License Plate Clock (AP) 17.00/ea.

PV329 "Pontiac Racing" License Plate Clock (AP) 17.00/ea.

These are great battery-operated clocks. Hang them in your shop, garage, den or game room. Equipped with bold brass hands, these clocks have precision quartz movements and keep excellent time.

Note: Battery not included.



PV327

LICENSE PLATES



PV301

PV301 Gr-rrr! License Plate—Orange w/Black Letters (AP) 5.00/ea.



PV302

PV302 Pontiac License Plate (AP) 5.00/ea.



PV304

PV304 "Pontiac - We Build Excitement" License Plate - White or Black (AP) 5.00/ea.



PV305

PV305 "Tin Indian" License Plate (AP) 5.00/ea.

2 DOOR BUMPER STOP KITS

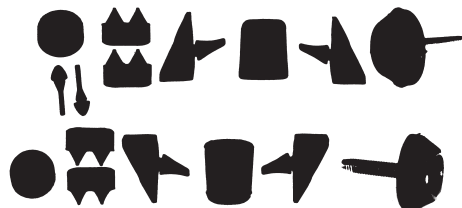

PV401 1955-57 Bumper Stop Kit (RE) 25.00/kit

PV403 1958 Bumper Stop Kit (RE) 25.00/kit

PV405 1959-62 Bumper Stop Kit (RE) 29.00/kit

PV406 1963 Bumper Stop Kit (RE) 30.00/kit

PV407 1964 Bumper Stop Kit (RE) 25.00/kit

PV408 1965 Bumper Stop Kit (RE) 25.00/kit

PV409 1966 Bumper Stop Kit (RE) 25.00/kit

PV411 1967 Bumper Stop Kit (RE) 30.00/kit

PV413 1968 Bumper Stop Kit (RE) 30.00/kit

PV415 1969 Bumper Stop Kit - FS (RE) 28.00/kit

PV417 1970 Bumper Stop Kit - FS (RE) 28.00/kit

PV419 1971-76 Bumper Stop Kit - FS (RE) 28.00/kit

PV421 1969 Bumper Stop Kit - GP (RE) 30.00/kit

PV423 1970-72 Bumper Stop Kit - GP (RE) 30.00/kit

Each kit contains the correct hood-to-fender bumpers, hood front bumpers, glove box bumpers, door bumpers, and trunk bumpers.

Note: Some 4-door bumper stop kits are available. Please inquire.



PV305B

PV305B "Grand Prix" License Plate (AP) 5.00/ea.



PV306

PV306 "Pontiac Racing" License Plate (AP) 5.00/ea.

TALK ABOUT FAST SERVICE!

AT AMES PERFORMANCE, WE HAVE ALWAYS MADE QUICK DELIVERY A HIGH PRIORITY. OUR VAST INVENTORY & EFFICIENT ORDER PROCESSING HAS KEPT THIS TRADITION ALIVE FOR OVER 30 YEARS.

IF YOU WANT YOUR PARTS FAST, WE'RE ONLY A PHONE CALL AWAY



LOCK SETS DOORS AND IGNITION



PV501	1955-57	Ignition and Door Lock Set w/2 Original-Style Keys -Sedans (NOS)	\$51.00/set
PV505	1955-57	Ignition and Door Lock Set w/2 Original-Style Keys - 2 Dr. HT and CVT (NOS)51.00/set
PV509	1955-57	Ignition and Door Lock Set w/2 Original-Style Keys - 4 Dr. HT (NOS)51.00/set
PV511	1955-57	Ignition and Door Lock Set w/2 Late-Style Keys - 4 Dr. HT (NOS)45.00/set
PV513	1958	Ignition and Door Lock Set w/2 Original-Style Keys -All Exc. SW(NOS)51.00/set
PV515	1958	Ignition and Door Lock Set w/2 Original-Style Keys - SW (NOS)51.00/set
PV517	1959	Ignition and Door Lock Set w/2 Original-Style Keys -All 2 Dr. Models (NOS)Disc.
PV523	1960	Ignition and Door Lock Set w/2 Original-Style Keys - All 4 Dr. Models(NOS)Disc.
PV525	1961-64	Ignition and Door Lock Set w/2 Original-Style Keys- Exc. 4 Dr. HT(NOS)46.00/set
PV529	1961-64	Ignition and Door Lock Set w/2 Original-Style Keys - 4 Dr. HT (NOS)51.00/set
PV531	1961-64	Ignition and Door Lock Set w/2 Late-Style Keys - 4 Dr. HT (NOS)46.00/set
PV533	1965	Ignition and Door Lock Set w/2 Original-Style Keys (NOS)67.00/set
PV537	1966	Ignition and Door Lock Set w/2 Original-Style Keys (NOS)Inquire
PV541	1967	Ignition and Door Lock Set w/2 Original-Style Keys (NOS)Inquire
PV545	1968	Ignition and Door Lock Set w/2 Original-Style Keys (NOS)37.00/set
PV547	1968	Ignition and Door Lock Set w/2 Late-Style Keys (NOS)31.00/set
PV549	1969-70	Ignition and Door Lock Set w/2 Keys - All (NOS)31.00/set
PV551	1971-73	Ignition and Door Lock Set w/2 Keys - FS (NOS)31.00/set
PV553	1971-73	Ignition and Door Lock Set w/2 Keys - GP (NOS)31.00/set

GLOVE BOX AND DECK LID



PV575	1955-58	Glove Box and Deck Lid Lock Set w/2 Original-Style Keys (NOS)49.00/set
PV577	1955-58	Glove Box and Deck Lid Lock Set w/2 Late-Style Keys (NOS)41.00/set
PV579	1959-60	Glove Box and Deck Lid Lock Set w/2 Original-Style Keys (NOS)36.00/set
PV581	1959-60	Glove Box and Deck Lid Lock Set w/2 Late-Style Keys (NOS)33.00/set
PV587	1961-62	Glove Box and Deck Lid Lock Set w/2 Original-Style Keys - Exc. GP (NOS)37.00/set
PV589	1961-62	Glove Box and Deck Lid Lock Set w/2 Late-Style Keys - Exc. GP (NOS)32.00/set
PV590	1962	Glove Box and Deck Lid Lock Set w/2 Original-Style Keys - GP (NOS)47.00/set
PV590A	1962	Glove Box and Deck Lid Lock Set w/2 Late-Style Keys - GP (NOS)36.00/set
PV591	1963-64	Glove Box and Deck Lid Lock Set w/2 Original-Style Keys - Exc. GP (NOS)34.00/set
PV595	1965	Glove Box and Deck Lid Lock Set w/2 Original-Style Keys - Exc. GP (NOS)37.00/set
PV595A	1965	Glove Box and Deck Lid Lock Set w/2 Late-Style Keys - Exc. GP (NOS)31.00/set
PV596	1966	Glove Box and Deck Lid Lock Set w/2 Original-Style Keys - Exc. GP (NOS)37.00/set
PV596A	1966	Glove Box and Deck Lid Lock Set w/2 Late-Style Keys - Exc. GP (NOS)31.00/set
PV597	1967	Glove Box and Deck Lid Lock Set w/2 Original-Style Keys - All Exc. Bonneville & GP (NOS)51.00/set
PV599	1967	Glove Box and Deck Lid Lock Set w/2 Late-Style Keys - All Exc. Bonneville & GP (NOS)26.00/set
PV601	1967	Glove Box and Deck Lid Lock Set w/2 Original-Style Keys - Bonneville & GP (NOS)47.00/set
PV603	1967	Glove Box and Deck Lid Lock Set w/2 Late-Style Keys - Bonneville & GP (NOS)36.00/set
PV605	1968	Glove Box and Deck Lid Lock Set w/2 Original-Style Keys (NOS)37.00/set
PV607	1968	Glove Box and Deck Lid Lock Set w/2 Late-Style Keys (NOS)32.00/set
PV609	1969	Glove Box and Deck Lid Lock Set w/2 Keys - FS (NOS)41.00/set
PV609A	1970-77	Glove Box and Deck Lid Lock Set w/2 Keys -FS (NOS)33.00/set
PV611	1969-72	Glove Box and Deck Lid Lock Set w/2 Keys -GP (NOS)Inquire
PV609A	1973-77	Glove Box and Deck Lid Lock Set w/2 Keys -GP (NOS)33.00/set

CONSOLE, GLOVE BOX, AND DECK LID



PV625	1962	Console, Glove Box and Deck Lid Lock Set w/2 Original-Style Keys - Exc. GP (NOS)	50.00/set
PV627	1962	Console, Glove Box and Deck Lid Lock Set w/2 Late-Style Keys - Exc. GP (NOS)	50.00/set
PV629	1963-64	Console, Glove Box and Deck Lid Lock Set w/2 Original-Style Keys - Exc. GP (NOS)	54.00/set
PV631	1963-64	Console, Glove Box and Deck Lid Lock Set w/2 Late-Style Keys - Exc. GP (NOS)	50.00/set
PV633	1965	Console, Glove Box and Deck Lid Lock Set w/2 Original-Style Keys - Exc. GP (NOS)	56.00/set
PV635	1965	Console, Glove Box and Deck Lid Lock Set w/2 Late-Style Keys - Exc. GP (NOS)	50.00/set
PV637	1966	Console, Glove Box and Deck Lid Lock Set w/2 Original-Style Keys - Exc. GP (NOS)	54.00/set
PV639	1966	Console, Glove Box and Deck Lid Lock Set w/2 Late-Style Keys - Exc. GP (NOS)	50.00/set
PV641	1967	Console, Glove Box and Deck Lid Lock Set w/2 Original-Style Keys - All exc. Bonneville & GP (NOS)	46.00/set
PV643	1967	Console, Glove Box and Deck Lid Lock Set w/2 Late-Style Keys - All exc. Bonneville & GP (NOS)	42.00/set
PV645	1967	Console, Glove Box and Deck Lid Lock Set w/2 Original-Style Keys - Bonneville & GP (NOS)	61.00/set
PV647	1967	Console, Glove Box and Deck Lid Lock Set w/2 Late-Style Keys - Bonneville & GP (NOS)	46.00/set
PV649	1968	Console, Glove Box and Deck Lid Lock Set w/2 Original-Style Keys (NOS)	54.00/set
PV651	1968	Console, Glove Box and Deck Lid Lock Set w/2 Late-Style Keys (NOS)	50.00/set

CONSOLE AND DECK LID

PV675	1969-72	Console and Deck Lid Lock Set w/2 Keys - GP (NOS)	31.00/set
--------------	---------	---	-------	-----------

Note: This set utilizes the black bezel on the console lock.



DOOR, GLOVE BOX, AND DECK LID

PV691	1974-76	Door, Glove Box and Deck Lid Lock Set w/2 Keys - FS (NOS)	51.00/set
PV693	1974-77	Door, Glove Box and Deck Lid Lock Set w/2 Keys - GP (NOS)	51.00/set

LITERATURE

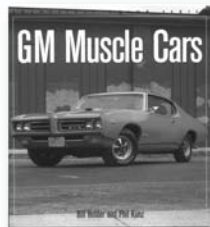

PW105B

PW105B GM Muscle Cars by Bill Holder and Phil Kunz \$15.00/ea.
A compilation of GM muscle cars by brand. Each brand receives a short history with numerous color photographs. The Pontiac section is 21 pages covering the GTO and Firebird.

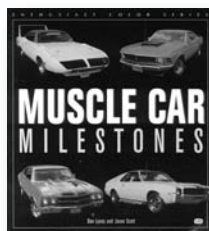

PW105C

PW105C *Musclecar Milestones* by Don Lyons and Jason Scott 15.00/ea.
Contains information on all makes of musclecars. Not geared toward Pontiac specifically but has specifications on many and their major competitors of the 1960's and 1970's.

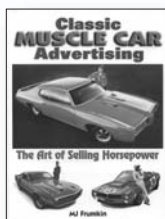

PW105E

PW105E *Musclecar Advertising - The Art of Selling Horsepower* by MJ Frumkin Disc.

PW105E covers some of the most aggressive performance-minded advertising ever used. Includes many different magazine advertisements from 1962-74, a period when horsepower and musclecars ruled the streets of America. 160 pages with 160+ color photos. All makes of American muscle.



PW105G

PW105G 101 GM Musclecar Performance Projects by Colin Date & Mitch Burns..... 29.00/ea.
This book covers 101 hands-on projects covering interior, exterior, drivetrain, suspension, and electrical. Each project includes time estimates, skill level, tools needed, and estimated project cost.

PW107A Road and Track on Pontiac 1960-83 Disc.
Very similar to PW107 with an emphasis on later model Pontiacs. Articles cover '64 GTO, '66 Sprint, Firebird, Fitch T/A, Racing T/A, Type K, Turbo T/A, Formula Convertible, Petty Grand National, 6000 STE, Grand Am, Bonneville, and Fiero.

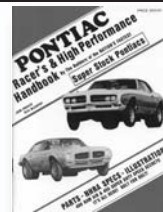

PW109

PW109 Pontiac Racer's High-Performance Handbook by Pete McCarthy \$20.00/ea.

Written from hands-on experience by three California drag racers. It completely explores all facets of high-performance Pontiac engines. The book covers part numbers, casting numbers, and the author's view of best blocks, heads, cams, etc. 100 pages with 82 illustrations. This book deals almost exclusively with performance Pontiac engines.

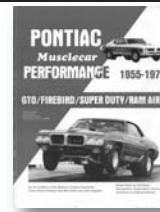

PW110

PW110 Pontiac Muscle Car Performance 1955-79 by Pete McCarthy 32.00/ea.

This publication is the most definitive work on Pontiac engines and drive trains ever attempted. It contains the information of PW109 plus numbers for all engine components from 1955 to 1979. Pete spent years on this project which also includes histories and documentation of the factory racecars. 224 pages.



PW112

PW112 Pontiac High-Performance Engine Design & Blueprint Assembly by Craig Hendrickson & Kern Osterstock 20.00/ea.

This is another fine book written by drag racers Craig Hendrickson and Kern Osterstock, well-known for their original work at H-O Racing Specialties. It delves into various modifications to increase power from your Pontiac. They also outline the construction of a full-competition engine for street and strip. 96 pages with 31 illustrations.

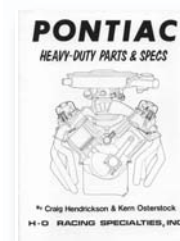

PW113

PW113 Pontiac Heavy-duty Parts and Specs by Craig Hendrickson and Kern Osterstock 10.00/ea.

Another H-O books, this softbound publication details parts and specifications for all high-performance Pontiacs of the 60's and 70's. 31 pages.

Note: Both PW112 and PW113 are highly recommended.

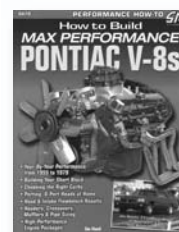

PW114C

PW114C How to Build Maximum Performance Pontiac V8's by Jim Hand 18.00/ea.

PW114C covers a range from mild performance upgrades to all-out high-performance build-ups for 1955-79 Pontiac V8's. Includes information on carburetors, intakes, heads, exhaust, and other engine-related topics.

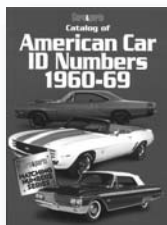

PW117

- PW116** Catalog of American Car ID Numbers 1950-59 Disc.
- PW117** Catalog of American Car ID Numbers 1960-69 \$30.00/ea.
- PW118** Catalog of American Car ID Numbers 1970-79 30.00/ea.

These books were compiled by the staff at Cars & Parts Magazine. They contain the keys to deciphering VIN codes, cowl tags, engine numbers, trim codes, and paint codes.



PW125

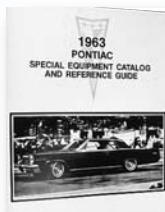

PW126

- PW125** 1962 Pontiac High Performance and Super-Duty Specification and Parts Manual (Reprint) 10.00/ea.
- PW126** 1963 Pontiac Special Equipment Catalog and Reference Guide (Reprint) 10.00/ea.



PW131

- PW131** How to Restore Metal Auto Trim by John Gunnell 18.00/ea.
Excellent book for showing how to remove and fix chrome, stainless and aluminum trim. Everything from tools to cleaning, repairing, welding, straightening and buffing. 96 pages.
- PW133A** How to Rebuild and Modify Your Musclicar by Jason Scott Disc.



PW133B



PW133C

- PW133B** How to Restore Your Musclicar By Paul Zazarine (AP) 34.00/ea.
PW133B explores 12 classic musclicar restorations with 1300 technical photographs and step-by-step how-to instructions. Includes GM, Ford, Chrysler, and AMC.
- PW133C** How to Paint Your Car on a Budget By Pat Ganahl 24.00/ea.
PW133C discusses how to prep and paint your car at home, in your own garage on a budget. Covers: tools needed, body work, and pre-paint techniques, through color-sanding and buffing out the final product. A must for the novice painter.

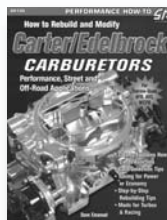

PW134



PW135



PW138K

- PW134** Super Tuning and Modifying Carter Carburetors By Dave Emanuel \$22.00/ea.
- PW135** Rochester Quadrajct Carburetors by Cliff Ruggles 24.00/ea.
PW134 and PW135 offer history and a large amount of technical information.
- PW138K** How To Build High Performance Ignition Systems by Todd Ryan 25.00/ea.

How to Build High-Performance Ignition Systems is the complete guide to understanding automotive ignition systems, from old-school points and condensers to modern computer-controlled distributorless systems, from bone-stock to totally aftermarket. 144 Pages - 275 color photos and wiring diagrams.

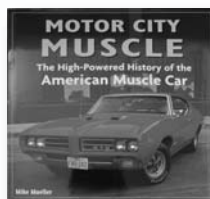

PW143

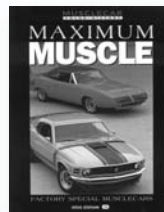

PW145



PW149

- PW143** Motor City Muscle by Mike Mueller 32.00/ea.
This hardcover book offers a comprehensive overview of the musclicar era. Included are sections on the Pontiac GTO, Trans Am, and full-size cars. This book also contains an incredible amount of information on other makes from this period. 192 pages, excellent photography.
- PW145** Maximum Muscle-Factory Special Musclicars ... 22.00/ea.
This book covers all American car companies factory hot rods including Pontiacs from the early Super Duty cars through the Firehawks of the 90's. 128 pages with color photos.
- PW148** Standard Catalog of American Cars 1946-1975 edited by John Gunnell Disc.
- PW149** Standard Catalog of American Cars 1976-1999 37.00/ea.
PW149 covers various models, production figures and options, plus pinpoints good investments and future collectibles.

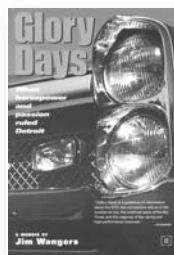

PW154



PW155H

- PW154** Glory Days: When Horsepower and Passion Ruled Detroit by Jim Wangers 35.00/ea.
PW154 gives fresh insight into the birth of the Pontiac GTO. Jim Wangers was responsible for the marketing campaign that propelled Pontiac to the forefront of the muscle car era. Jim uses his 45-year career to provide his view of those times.
- PW155H** Complete Hurst Shifter Guide 34.00/ea.
PW155H covers Hurst shifters from 1960-1970. Some items covered are Hurst history, shifter identification, and a vast listing of shifters used by the 4 major American car makers of this era. 144 pages.



PW157

PW157 Turbo-Hydra-matic 350 Handbook
by Ron Sessions \$19.00/ea.

PW158 Turbo-Hydra-matic 400 Transmission
by Ron Sessions Disc.

These books go deeper into troubleshooting and repairing transmissions. Very detailed information is supplied in the text. These books also contain information on special performance modifications for the street or track.

PW157M How To Build/Modify Manual Transmissions
by Paul Cangialosi 24.00/ea

Breaks down the disassembly, inspection, modification/upgrade, and rebuilding process into detailed yet easy-to-follow steps. Transmission expert Paul Cangialosi shares his proven rebuilding methods, and 27 years of knowledge. He guides you through the rebuilding process for most major high-performance transmissions, including T10 and super T10, Muncie, and others. Also explains theory, gear-ratio calculation, synchro function, and gear design features, so you possess the know-how to build best gearbox. 400 photos, charts, and illustrations.



PW157M



PW159

PW159 Muscle Car Interior Restoration Guide
by Daniel Strohl 29.00/ea.

The Muscle Car Interior Restoration Guide provides expert insight into the tools, materials, techniques, and procedures for professionally completing a muscle car restoration. It covers instrument panel and dashboard restoration, electrical system restoration, firewall pad, steering wheel, steering column, and pedal restoration. It also provides insight and expert guidance for restoring carpet, headliners, doors, door panels, glass restoration or replacement, convertible top restoration, upholstery replacement, and vinyl and leather seat repair.

ASSEMBLY MANUALS

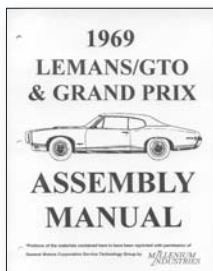

PW170 1969 Grand Prix Assembly Manual 19.00/ea.
PW180 1970 Grand Prix Assembly Manual 19.00/ea.
PW181 1971 Grand Prix Assembly Manual 19.00/ea.

Assembly manuals are used on GM production lines to show workers how each piece is assembled and installed. These assembly manual photocopies cover 1969 - 71 Grand Prix, Tempest, LeMans, and GTO. They include an exploded view of every section of the car detailing all part numbers and installation procedures. This once privileged information is invaluable to any restorer.

Comments: Photocopy work is fair to good.

FACTORY SHOP MANUALS ON CD



PW219 1955 Factory Shop Manual on CD \$49.00/ea.
PW219B 1956 Factory Shop Manual on CD 49.00/ea.
PW219C 1957 Factory Shop Manual on CD 49.00/ea.
PW219CA 1958 Factory Shop Manual on CD 49.00/ea.
PW219D 1959 Factory Shop Manual on CD 49.00/ea.
PW219F 1960 Factory Shop Manual on CD 49.00/ea.
PW219K 1961 Factory Shop Manual on CD 49.00/ea.
PW219M 1962 Factory Shop Manual on CD 49.00/ea.

Note: PW219M includes Tempest also.

PW219P 1963 Factory Shop Manual on CD 49.00/ea.

Note: PW219P includes Tempest also.

PW220 1964 Factory Shop Manual on CD 49.00/ea.
PW220B 1965 Factory Shop Manual on CD 49.00/ea.
PW220D 1966 Factory Shop Manual on CD 49.00/ea.
PW220F 1967 Factory Shop Manual on CD 49.00/ea.
PW220H 1968 Factory Shop Manual on CD 49.00/ea.
PW220K 1969 Factory Shop Manual on CD 49.00/ea.
PW221 1970 Factory Shop Manual on CD 49.00/ea.
PW221B 1971 Factory Shop Manual on CD 49.00/ea.
PW221D 1972 Factory Shop Manual on CD 49.00/ea.
PW222 1963-72 Factory Shop Manual, 10 CD Set 399.00/set

These CDs are an indispensable tool for restorers. Each disc contains the factory shop manual and Fisher body manual (58-later only) for the specific year. In addition many years include the GM parts book to help locate original part numbers. The parts book is from the early 1980's, therefore, any parts discontinued before that time will not be included. Requires Adobe Acrobat 5.5 or newer.

FISHER BODY MANUALS



PW230

PW226A 1955 Pontiac SW Body Manual (Reprint) 15.00/ea.
PW226D 1958 Pontiac Body Manual (Reprint) 19.00/ea.
PW226G 1961 Pontiac Body Manual (Reprint) 19.00/ea.
PW226H 1962 Pontiac Body Manual (Reprint) 30.00/ea.
PW227 1963 Fisher Body Manual (Reprint) 30.00/ea.
PW228 1964 Fisher Body Manual (Reprint) 30.00/ea.
PW229 1965 Fisher Body Manual (Photocopy) 42.00/ea.
PW230 1966 Fisher Body Manual (Reprint) 30.00/ea.
PW231 1967 Fisher Body Manual (Reprint) 30.00/ea.
PW232 1968 Fisher Body Manual (Reprint) 30.00/ea.
PW233 1969 Fisher Body Manual (Reprint) 30.00/ea.
PW234 1970 Fisher Body Manual (Reprint) 30.00/ea.
PW235 1971 Fisher Body Manual (Reprint) 30.00/ea.
PW236 1972 Fisher Body Manual (Reprint) 30.00/ea.

Fisher body manuals explore all aspects of disassembling, servicing, and installation of GM body components. Combine these with our shop manuals, and you will have more than adequate information for all aspects of your restoration.

SHOP MANUALS

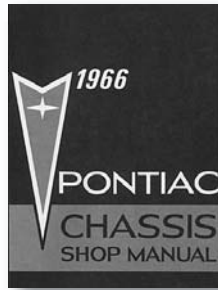

PW252

PW242	1955	Shop Manual Body/Chassis (Reprint)	\$45.00/ea.
PW242A	1956	Shop Manual Body/Chassis (Reprint)	35.00/ea.
PW243	1957	Shop Manual Chassis Only (Reprint)	35.00/ea.
PW243B	1956-57	Hydramatic Trans. Shop Manual (Reprint)	19.00/ea.
PW244	1958	Shop Manual Body/Chassis (Reprint)...	45.00/ea.
PW244B	1958-59	Hydramatic Trans. Shop Manual (Reprint)	19.00/ea.
PW244C	1958	Fuel Injection Manual (Reprint).....	12.00/ea.
PW245	1959	Shop Manual Chassis Only (Reprint)	55.00/ea.
PW246	1960	Shop Manual Body Only (Reprint)	22.00/ea.
PW246A	1960	Shop Manual Chassis Only (Reprint)	35.00/ea.
PW246C	1960	HVAC Manual (Reprint)	20.00/ea.
PW246D	1960	Hydramatic Trans. Manual (Reprint)....	18.00/ea.
PW247	1961	Shop Manual Chassis Only (Reprint)	41.00/ea.
PW248	1962	Shop Manual Chassis Only (Reprint)	39.00/ea.
PW248B	1962	A/C Manual, All Models (Reprint)	24.00/ea.
PW249	1963	Shop Manual Chassis Only(Reprint).....	50.00/ea.
PW250	1964	Shop Manual Body Only (Reprint)	Disc.
PW251	1965	Shop Manual Chassis Only(Reprint).....	45.00/ea.
PW252	1966	Shop Manual - Full-Size Pontiac Models (Reprint)	48.00/ea.
PW252AC	1966	A/C Supplement, All Models (Reprint) ..	20.00/ea.
PW253	1967	Shop Manual - All Models (Reprint)	45.00/ea.
PW254	1968	Shop Manual - All Models (Reprint).....	39.00/ea.
PW255	1969	Shop Manual - All Models (Reprint)	42.00/ea.
PW256	1970	Shop Manual - All Models (Photocopy)	70.00/set
PW257	1971	Shop Manual - All Models (Reprint)	99.00/ea.
PW257B	1972	Shop Manual - All Models (Reprint)	95.00/ea.
PW257D	1973	Shop Manual - All Models (Reprint)	89.00/ea.
PW257F	1974	Shop Manual - All Models (Reprint)	89.00/ea.
PW257F	1975	Shop Manual - All Models (Reprint)	89.00/ea.
PW257L	1976	Shop Manual Supplement - All Models (Reprint).....	32.00/ea.
PW257M	1977	Shop Manual - All Models (Reprint)	95.00/ea.
PW265	1965	Pontiac Inspectors Manual (RE).....	15.00/ea.



OWNER'S MANUALS



PW282

PW270	1955	Pontiac Owners Manual (Reprint)	\$20.00/ea.
PW271	1956	Pontiac Owners Manual (Reprint)	20.00/ea.
PW272	1957	Pontiac Owner's Manual (Reprint)	20.00/ea.
PW273	1958	Pontiac Owners Manual (Reprint)	20.00/ea.
PW274	1959	Pontiac Owners Manual (Reprint)	20.00/ea.
PW275	1960	Pontiac Owners Manual (Reprint)	20.00/ea.
PW280	1965	Pontiac Owner's Manual.....	12.00/ea.
PW281	1966	Pontiac Owner's Manual.....	12.00/ea.
PW282	1967	Pontiac Owner's Manual.....	12.00/ea.
PW283	1968	Pontiac Owner's Manual.....	12.00/ea.
PW284	1969	Pontiac Owner's Manual.....	12.00/ea.
PW285	1970	Pontiac Owner's Manual.....	12.00/ea.

CONVERTIBLE TOP MANUALS

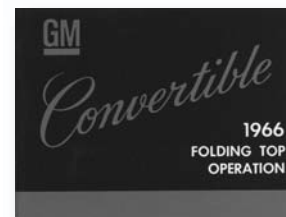

PW327

PW322	1961	Convertible Top Manual (GM)	7.00/ea.
PW323	1962	Convertible Top Manual (GM)	7.00/ea.
PW324	1963	Convertible Top Manual (GM)	7.00/ea.
PW325	1964	Convertible Top Manual (GM)	7.00/ea.
PW326	1965	Convertible Top Manual (GM)	7.00/ea.
PW327	1966	Convertible Top Manual (GM)	7.00/ea.
PW328	1967	Convertible Top Manual (GM)	7.00/ea.
PW329	1968	Convertible Top Manual (GM)	7.00/ea.

All convertibles were originally supplied with this manual in the glovebox. It covers operation and maintenance of the convertible top.

PW340	1964	New Car Accessory Price List (RE).....	3.00/ea.
--------------	------	--	----------

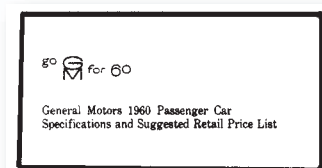

PW370

PW370	1960	Pontiac GM Cars Retail Price Book(RE)	3.50/ea.
PW374	1964	Pontiac GM Cars Retail Price Book (RE)	3.50/ea.
PW375	1965	Pontiac GM Cars Retail Price Book (RE)	3.50/ea.
PW376	1966	Pontiac GM Cars Retail Price Book (RE)	3.50/ea.
PW381	1971	Pontiac GM Cars Retail Price Book (RE)	3.50/ea.
PW408	1964	Widetrack Accessories Catalog (NOS)..	12.00/ea.

PW408 is the original accessory portion from the dealer showroom literature catalog for all 1964 Pontiac models. Includes: basic group options, lamps, protection, decor, mirrors, individual options and accessories, and Safari accessories.

IMPORTANT NOTE:

This catalog covers all full-size Pontiac models from 1955-76 and Grand Prix up to 1977. In 1969 Pontiac changed the Grand Prix from the full-size "B" body to the intermediate size "G" body. To avoid confusion for the years 1969-1977, we will use "ALL" after the part description if the part fits both Grand Prix and full-size. If a part fits only full-size models then "FS" will follow the part description. If a part only fits Grand Prix, then "GP" will follow the part description. Please note this when ordering.

INTERIORS

INTERIOR PAINT

After many requests from you, our customers, we will be carrying a high-quality line of interior grade paints. To deliver the highest quality available, much research and testing has gone into deciding on this particular product. Currently, we are developing a line of colors to match the PUI brand interior products. Please inquire regarding Legendary brand colors. The last three digits of the following part numbers correspond with PUI vinyl color codes. ie: VDM27 is equivalent to PUI's # M27 parchment. **This line of interior paints is only available from Ames Performance.**

**EXCLUSIVE COLOR
MATCHING**



VDS52	Interior Paint, 12oz Aerosol, Dk. Aqua (APE)	\$12.00/ea.
VDS54	Interior Paint, 12oz Aerosol, Dark Blue (APE).....	12.00/ea.
VDS64	Interior Paint, 12oz Aerosol, Red (APE)	12.00/ea.
VDS65	Interior Paint, 12oz Aerosol, Saddle (APE)	12.00/ea.
VDS69	Interior Paint, 12oz Aerosol, White (APE)	12.00/ea.
VDM02	Interior Paint, 12oz Aerosol, Light Aqua (APE)	12.00/ea.
VDM04	Interior Paint, 12oz Aerosol, Aqua (APE).....	12.00/ea.
VDM06	Interior Paint, 12oz Aerosol, Mustard Gold (APE) .	12.00/ea.
VDM07	Interior Paint, 12oz Aerosol, Sienna Brown (APE) .	12.00/ea.
VDM08	Interior Paint, 12oz Aerosol, Metallic Red (APE) ...	12.00/ea.
VDM09	Interior Paint, 12oz Aerosol, Medium Blue (APE)..	12.00/ea.
VDBLK	Interior Paint, 12oz Aerosol, Black (APE)	12.00/ea.
VDM12	Interior Paint, 12oz Aerosol, Light Blue (APE).....	12.00/ea.
VDM14	Interior Paint, 12oz Aerosol, Bright Blue (APE)	12.00/ea.

VDM15	Interior Paint, 12oz Aerosol, Medium Blue (APE)..	\$12.00/ea.
VDM16	Interior Paint, 12oz Aerosol, Dark Blue (APE).....	12.00/ea.
VDM17	Interior Paint, 12oz Aerosol, Teal Blue (APE)	12.00/ea.
VDM18	Interior Paint, 12oz Aerosol, Navy Blue (APE)	12.00/ea.
VDM19	Interior Paint, 12oz Aerosol, Jade Green (APE).....	12.00/ea.
VDM24	Interior Paint, 12oz Aerosol, Dark Green (APE).....	12.00/ea.
VDM25	Interior Paint, 12oz Aerosol, Green (APE)	12.00/ea.
VDM27	Interior Paint, 12oz Aerosol, Parchment (APE).....	12.00/ea.
VDM28	Interior Paint, 12oz Aerosol, Pearl (APE)	12.00/ea.
VDM30	Interior Paint, 12oz Aerosol, Red (APE)	12.00/ea.
VDM31	Interior Paint, 12oz Aerosol, Bright Red (APE)	12.00/ea.
VDM32	Interior Paint, 12oz Aerosol, Bright Red (APE)	12.00/ea.
VDM35	Interior Paint, 12oz Aerosol, Light Saddle (APE)	12.00/ea.
VDM36	Interior Paint, 12oz Aerosol, Saddle (APE)	12.00/ea.
VDM37	Interior Paint, 12oz Aerosol, White (APE)	12.00/ea.
VDM40	Interior Paint, 12oz Aerosol, Off White (APE).....	12.00/ea.
VDM41	Interior Paint, 12oz Aerosol, Sandalwood (APE)....	12.00/ea.
VDM42	Interior Paint, 12oz Aerosol, Dark Saddle (APE)....	12.00/ea.
VDM43	Interior Paint, 12oz Aerosol, Gold (APE)	12.00/ea.
VDM46	Interior Paint, 12oz Aerosol, Ivy Gold (APE).....	12.00/ea.
V862	Vinyl Prep Solution, 4oz Bottle (AP)	12.00/ea.
V863	Vinyl Dye Adhesion Promoter, 12oz Aerosol (AP)	12.00/ea.

VINYL YARDAGE

Vinyl yardage is available. Price is \$30.00 per running yard (36" x 54") of Seville or Madrid grain. Please call for samples. Other grains are also available. Please call for pricing.

DON'T MISS THE 2011

Ames Performance

Pontiac Nationals

Ames Performance

TRI-POWER PONTIAC NATIONALS!

THE WORLD'S LARGEST ALL-PONTIAC SHOW AND RACE EVENT

August 2011 - Summit Motorsports Park - Norwalk, OH

For show dates and more information contact:

Super Duty Promotions

P.O. Box 714 - Norwalk, OH 44857

(419)663-7383

For highlights from past years and information on the 2011 upcoming event, go to:

www.amesperf.com

PUI SEAT UPHOLSTERY



For over 20 years PUI has been a leading manufacturer of interior components. Their focus on quality and customer service is the best in the industry. Using time-tested patterning methods they are able to give you excellent fit, color, and appearance for your project. PUI's seat covers are precision cut on an automated cutter insuring the same fit time after time. Their colors are specifically run for PUI, and by working closely with their material suppliers, they are able to insure accurate and consistent color match from part to part. PUI's interior components come with a 2-year warranty.

Samples must be seen before ordering colored seats.

Please add \$12.00 oversize fee to standard shipping for seat kits.



1962



1962 Colors: Black, White, Light Blue, Red, Saddle

- PA020A** 1962 Complete Seat Upholstery Kit - GP (2 Buckets and Rear) (RE) \$569.00/set
- PA020C** 1962 Bucket Seat Upholstery - GP (Pairs Only) (RE) 379.00/pr.
- PA020D** 1962 Rear Seat Upholstery - GP (RE) 219.00/ea.

1963



1963 Colors: Black, White, Dark Blue, Aqua, Red, Saddle

- PA022** 1963 Complete Seat Upholstery Kit - GP (2 Buckets and Rear) (RE) 569.00/set
- PA022C** 1963 Bucket Seat Upholstery - GP (Pairs Only) (RE) 379.00/pr.
- PA022D** 1963 Rear Seat Upholstery - GP (RE) 219.00/ea.

Note: The pleat size differs slightly from original; otherwise, an excellent product.

1964



1964 Colors: Black, White, Dark Blue, Aqua, Red

- PA026** 1964 Complete Seat Upholstery Kit - GP (2 Buckets and Rear) (RE) 569.00/set
- PA026C** 1964 Bucket Seat Upholstery - GP (Pairs Only) (RE) 379.00/pr.
- PA026D** 1964 Rear Seat Upholstery - GP (RE) 219.00/ea.

1965



1965 Colors: Black, Parchment, Dark Blue, Aqua, Metallic Red

- PA030** 1965 Complete Seat Upholstery Kit - GP (2 Buckets and Rear) (RE) \$515.00/set
- PA030C** 1965 Bucket Seat Upholstery - GP (Pairs Only) (RE) 289.00/pr.
- PA030D** 1965 Rear Seat Upholstery - GP (RE) 255.00/ea.
- PA031C** 1965 Bench Seat Upholstery - Bonneville (RE) 309.00/ea.
- PA032** 1965 Complete Seat Upholstery Kit - 2+2 HT (2 Buckets and Rear) (RE) 515.00/set
- PA032B** 1965 Complete Seat Upholstery Kit - 2+2 CVT (2 Buckets and Rear) (RE) 515.00/set
- PA032C** 1965 Bucket Seat Upholstery - 2+2 (Pairs Only) (RE) 289.00/pr.
- PA032D** 1965 Rear Seat Upholstery - 2+2 HT (RE) 255.00/ea.
- PA032G** 1965 Rear Seat Upholstery - 2+2 CVT (RE) 255.00/ea.
- PA033A** 1965 Complete Seat Upholstery Kit - Parisienne HT (2 Buckets and Rear) (RE) 515.00/set
- PA033B** 1965 Complete Seat Upholstery Kit - Parisienne CVT (2 Buckets and Rear) (RE) 515.00/set
- PA033C** 1965 Bucket Seat Upholstery - Parisienne (Pairs Only) (RE) 289.00/pr.
- PA033D** 1965 Rear Seat Upholstery - Parisienne HT (RE) 255.00/ea.
- PA033E** 1965 Rear Seat Upholstery - Parisienne CVT (RE) 255.00/ea.

1966



1966 Colors: Black, Parchment, Blue, Aqua, Metallic Red

- PA034** 1966 Complete Seat Upholstery Kit - GP (2 Buckets and Rear) (RE) 515.00/set
- PA034C** 1966 Bucket Seat Upholstery - GP (Pairs Only) (RE) 289.00/pr.
- PA034D** 1966 Rear Seat Upholstery - GP (RE) 255.00/ea.
- PA036** 1966 Complete Seat Upholstery Kit - 2+2 HT (2 Buckets and Rear) (RE) 515.00/set
- PA036B** 1966 Complete Seat Upholstery Kit - 2+2 CVT (2 Buckets and Rear) (RE) 515.00/set
- PA036C** 1966 Bucket Seat Upholstery - 2+2 (Pairs Only) (RE) 289.00/pr.
- PA036D** 1966 Rear Seat Upholstery - 2+2 HT (RE) 255.00/ea.
- PA036G** 1966 Rear Seat Upholstery - 2+2 CVT (RE) 255.00/ea.
- PA037CB** 1966 Bench Seat Upholstery - Bonneville (RE) 289.00/ea.

Seat Upholstery continues on next page.

Seat Upholstery continued.

1967



- 1967 Colors:** Black, Parchment, Aqua, Blue, Red, Gold
- | | | | |
|---------------|------|--|--------------|
| PA038 | 1967 | Complete Seat Upholstery Kit - GP
HT (2 Buckets and Rear) (RE) | \$515.00/set |
| PA038B | 1967 | Complete Seat Upholstery Kit - GP
CVT (2 Buckets and Rear) (RE) | 515.00/set |
| PA038C | 1967 | Bucket Seat Upholstery - GP
(Pairs Only) (RE) | 289.00/pr. |
| PA038D | 1967 | Rear Seat Upholstery - GP
HT (RE) | 255.00/ea. |
| PA038G | 1967 | Rear Seat Upholstery - GP
CVT (RE) | 255.00/ea. |
| PA039B | 1967 | Complete Seat Upholstery Kit -
Parisienne CVT (RE) | 515.00/set |
| PA039C | 1967 | Bucket Seat Upholstery -
Parisienne (Pairs Only) (RE)... | 289.00/pr. |
| PA039G | 1967 | Rear Seat Upholstery -
Parisienne CVT (RE) | 255.00/ea. |

1969



- 1969 Colors:** Black, Parchment, Dark Blue, Dark Green, Mustard Gold
- | | | | |
|---------------|------|--|------------|
| PA042 | 1969 | Complete Seat Upholstery Kit - GP
(2 Buckets and Rear) (RE) | 515.00/set |
| PA042C | 1969 | Bucket Seat Upholstery - GP
(Pairs Only) (RE) | 289.00/pr. |
| PA042D | 1969 | Rear Seat Upholstery - GP (RE) | 255.00/ea. |

1970



- 1970 Colors:** Black, Sandalwood, Light Saddle, Dark Green, Dark Blue
- | | | | |
|---------------|------|--|------------|
| PA044 | 1970 | Complete Seat Upholstery Kit - GP
(2 Buckets and Rear) (RE) | 515.00/set |
| PA044C | 1970 | Bucket Seat Upholstery - GP
(Pairs Only) (RE) | 289.00/pr. |
| PA044D | 1970 | Rear Seat Upholstery - GP (RE) | 255.00/ea. |

1971

- 1971 Colors:** Black, Sandalwood, Dark Saddle, White, Jade Green, Dark Blue, Sienna
- | | | | |
|---------------|------|--|------------|
| PA046 | 1971 | Complete Seat Upholstery Kit - GP
(2 Buckets and Rear) (RE) | 515.00/set |
| PA046C | 1971 | Bucket Seat Upholstery - GP
(Pairs Only) (RE) | 289.00/pr. |
| PA046D | 1971 | Rear Seat Upholstery - GP (RE) | 255.00/ea. |

1972



- 1972 Colors:** Black, Dark Green, White, Dark Saddle
- | | | | |
|---------------|------|--|--------------|
| PA048 | 1972 | Complete Seat Upholstery Kit - GP
(2 Buckets and Rear) (RE) | \$515.00/set |
| PA048C | 1972 | Bucket Seat Upholstery - GP
(Pairs Only) (RE) | 289.00/pr. |
| PA048D | 1972 | Rear Seat Upholstery - GP (RE) | 255.00/ea. |

Note: PA046-PA048D do not include the square trim buttons for the seats.

Note 1: Bucket seats are sold in pairs only.

Add \$12.00 oversize fee to standard shipping for orders that include complete seat kits.



BUCKET SEAT SPRINGS & FRAME



PA175FC

- | | | | |
|---|---------|--|-----------|
| PA175FC | 1962-65 | Bucket Seat Bottom Side Support
Spring Kit (RE) | 18.00/kit |
| Contains enough springs and fasteners for the sides of one bucket seat bottom. | | | |
| PA175FK | 1966-67 | Bucket Seat Bottom Side Support
Spring Kit (RE) | 29.00/kit |
| Contains enough springs and fasteners for the sides of one bucket seat bottom. | | | |
| PA175FN | 1968-72 | Bucket Seat Bottom Side Support
Spring Kit - All (RE) | 25.00/kit |
| Contains enough springs and fasteners for the sides of two bucket seat bottoms. | | | |

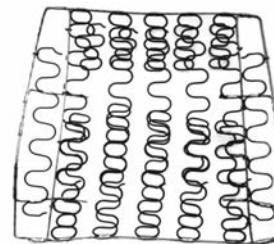

- | | | | |
|----------------|---------|---|-----------|
| PA175HB | 1962-65 | Bucket Seat Bottom Spring Assembly
w/Side Support Springs (RE) | 95.00/ea. |
| PA175HD | 1962-65 | Bucket Seat Back Spring Assembly (RE) | 89.00/ea. |
| PA175HH | 1966-67 | Bucket Seat Bottom Spring
Assembly w/Side Support Springs (RE).. | 95.00/ea. |
| PA175HK | 1966-67 | Bucket Seat Back Spring Assembly (RE) | 89.00/ea. |
| PA175HN | 1968-72 | Bucket Seat Bottom Spring
Assembly w/Side Support Springs - All (RE) | 95.00/ea. |
| PA175HR | 1968-72 | Bucket Seat Back Spring Assembly -All (RE) | 89.00/ea. |

Add \$5.00 oversize fee to standard shipping on seat spring assemblies.





PA175KR

PA175KL 1966-68 Bucket Seat Frame Assembly, LH (RE)... \$369.00/ea.

PA175KR 1966-68 Bucket Seat Frame Assembly, RH (RE).. 369.00/ea.

Add \$12.00 oversize fee to standard shipping for PA175KL-KR.



EXCELLENT QUALITY BUCKET SEAT PADDING

ACI seat cushions have proven to be the finest quality seat cushions on today's market. They are recommended for all interior restorations.

American Cushion Industries

Precision Molded Seat Cushions



- PA176J** 1962-65 Bucket Seat Padding (RE)..... 199.00/set
- PA177** 1966-72 Bucket Seat Padding (RE)..... 199.00/set
- PA177B** 1973-77 Bucket Seat Padding -GP (RE) 399.00/set

This four-piece contoured set of bucket seat foam restores original shape and resilience to worn buckets. If shape or foam density of your bucket is a problem, we recommend installing these seat pads.

Add \$16.00 oversize fee to standard shipping for bucket seat padding.



GOOD QUALITY BUCKET SEAT PADDING

With the costs of urethane foam products constantly rising, we found it necessary to offer another line of less-expensive seat padding. The following seat padding products exhibit good quality along with affordability.

- PA176JC** 1962-65 Bucket Seat Padding (RE)..... 149.00/set
- PA177BC** 1966-72 Bucket Seat Padding (RE)..... 149.00/set
- PA177BF** 1973-77 Bucket Seat Padding -GP (RE) 229.00/set

This four-piece contoured set of bucket seat foam restores original shape and resilience to worn buckets. If shape or foam density of your bucket is a problem, we recommend installing these seat pads.

Add \$16.00 oversize fee to standard shipping for bucket seat padding.



REAR SEAT PADDING



PA181 1955-77 Rear Seat Padding Kit (RE)..... \$59.00/kit

This 3/4" thick cotton pad and burlap combination is located between the spring assembly and the vinyl upholstery on rear seats. Originals were commonly used as nesting material by rodents.

HOG RINGS & PLIERS



PA182M

PA182M Upholstery Installation Kit (AP) 11.00/kit

For customers installing their own seat upholstery, this kit includes one pair of hog ring pliers and enough hog rings for one pair of bucket seats. Order an extra set of PA182MD for complete seat kit installations.

PA182MD Upholstery Hog Rings, 100 Count (RP). 2.00/pkg.



PA182MG

PA182MG Heavy Duty Upholstery Hog Ring Pliers, Straight End (AP)..... 23.00/ea.

PA182MJ Heavy Duty Upholstery Hog Ring Pliers, Curved End (AP)..... 23.00/ea.

PA182MN Heavy Duty Hog Ring Cutters (AP)..... 9.50/ea.

PA172MN

1966-67 BUCKET SEAT PANELS

These are plastic reproductions of the original steel panels used on 1966 and 1967 buckets. These have the correct grain and gloss as the originals. Panels come complete with chrome seat piping and piping end caps.

Colors Available: black, white, red, and aqua. For non-stocked colors please allow 1-2 weeks for delivery.

Add \$12.00 oversize fee to standard shipping for seat back panels.



PA173

PA173 1966-67 Bucket Seat Panel Screw Kit (AP)..... 6.00/set

PA173C 1966-67 Lower Seat Panel Spacers, 6pc. (RE) 7.50/set

PA174AN 1966 Plastic Bucket Seat Back Panels, Pair-Black (RP) 67.00/pr.

PA174AP 1966 Plastic Bucket Seat Back Panels, Pair-Colors (RP)..... 79.00/pr.

PA174AQ 1967 Plastic Bucket Seat Back Panels, Pair-Black (RP) 67.00/pr.



Bucket Seat Panels continue on next page.

Bucket Seat Panels continued.

PA174AR 1967 Plastic Bucket Seat Back Panels, Pair-Colors (RP)..... \$79.00/pr.
 Colors Available: black, white, red, and aqua. For non-stocked colors please allow 1-2 weeks for delivery.

PA174AS 1966-67 Plastic Bucket Seat Side Panels, 4 Pieces-Black (RP)..... 99.00/set

PA174AT 1966-67 Plastic Bucket Seat Side Panels, 4 Pieces-Colors (RP)..... 119.00/set

As a complement to the seat back panels we also offer the lower side panels. Made from the same grained plastic they also come complete with chrome seat piping. Each set consists of four pieces.

Colors Available: black, white, red, and aqua. For non-stocked colors please allow 1-2 weeks for delivery.

PA174AV 1966 Plastic Bucket Seat Back Panel Kit, 6 Pieces-Black (RP) 159.00/set

PA174AW 1966 Plastic Bucket Seat Back Panel Kit, 6 Pieces-Colors (RP) 189.00/set

PA174AX 1967 Plastic Bucket Seat Back Panel Kit, 6 Pieces-Black (RP) 159.00/set

PA174AY 1967 Plastic Bucket Seat Back Panel Kit, 6 Pieces-Colors (RP)..... 189.00/set

Colors Available: black, white, red, and aqua. For non-stocked colors please allow 1-2 weeks for delivery.

Add \$12.00 oversize fee to standard shipping on PA174AV-PA174AY.



1968-72 BUCKET SEAT PANELS

These are the plastic panels that make up the back of your bucket seats. Originals often are scratched or have disintegrated with age (many times producing a fine white powder).

These reproduction panels are much better than those previously available. They now have the correct simulated vinyl grain and correct gloss.

The '68 panels come complete with afterproduct chrome piping and piping caps, the 69-72 panels come with afterproduct chrome piping and correct molded ends on the panels.



PA174AYC

PA174AYC 1968 Bucket Seat Panel Screw Kit (AP)..... 6.00/kit
PA174B 1968 Bucket Seat Back Panels, Black (RE)..... 67.00/pr.
PA174BD 1968 Bucket Seat Back Panels, Colors (RE).... 79.00/pr.
PA173C 1968 Lower Seat Panel Spacers, 6pc. (RE)..... 7.50/set



PA174BJ

PA174AYD 1969-72 Bucket Seat Back Panel Screw Kit (AP) . 6.00/kit
PA174BJ 1969-72 Bucket Seat Back Panels, Black (RE)..... 67.00/pr.
PA174BK 1969-72 Bucket Seat Back Panels, Colors (RE)..... 79.00/pr.

Note: For '69-'71 bucket seat interiors with a passenger seat recliner use PA174B panels.

Add \$12.00 oversize fee to standard shipping for bucket seat back panels.



PA174BL

As a complement to the seat back panels we also offer the lower side panels. Made from the same grained plastic they also come complete with seat piping chrome. Each set consists of four pieces.

PA174BL 1968-72 Lower Side Seat Panel, Black (RE) \$99.00/set
PA174BM 1968-72 Lower Side Seat Panel, Colors (RE) 119.00/set

For the best possible savings, order your seat back panels and lower side seat panels as a kit.

Add \$12.00 oversize fee to standard shipping for PA174BL & PA174BM.



PA174BN 1968 Seat Panel Kit-Black 159.00/kit
PA174BP 1968 Seat Panel Kit-Colors 189.00/kit
PA174BS 1969-72 Seat Panel Kit-Black 159.00/kit
PA174BT 1969-72 Seat Panel Kit-Colors 189.00/kit

Add \$12.00 oversize fee to standard shipping for PA174BN through PA174BT.



BUCKET SEAT PIPING AND CAPS



PA177M 1966-67 Correct Molded Seat Piping Set (RE) 85.00/set
PA177N 1968-72 Correct Molded Seat Piping Set (RE) 85.00/set

This new reproduction seat piping is now complete and looks great. Unlike A133 and A133B, this will be made in the correct diameter and finish like original. In addition to this, all corners will be molded correctly.

Quality: very good.



PA178



PA179

PA178 1966-68 Bucket Seat Chrome Piping (AP) 13.00/set

This material is the chrome plastic bead that runs up the sides and over the top of the bucket seats. It is not an exact reproduction but conforms very close to original. Enough material is included to refinish both front buckets.

PA179 1966-68 Bucket Seat Chrome Piping Cap (RE).... 3.00/ea.

These are the small chrome caps that cover the ends of the PA178 piping. In many cases these are missing from original interiors.

PA180 1969-77 Bucket Seat Piping (RE)..... 1.00/ft.

Again, this is not an exact reproduction but works well. Major difference is smaller diameter.



PA184

PA184 1962-65 Bucket Seat Chrome Rod End Cap (RE). 3.00/ea.

This cap covers the pivot rod that allows the bucket seat back to fold forward.

BUCKET SEAT HEADRESTS, COVERS & COMPONENTS



PA174CB

PA174CB 1966-67 Bucket Seat Headrest Lock Mechanisms, Set of 4 (RE)..... \$179.00/set



PA174CD

PA174CD 1966-67 Bucket Seat Headrests, Black (RE) 159.00/pr.
PA174CH 1966-67 Bucket Seat Headrest Assemblies, Black (RE) 239.00/set

These assemblies will allow a complete conversion for 1966-1967 bucket seat cars without the headrest option. May also be used with original components. PA174CH is complete with headrests and lock mechanisms. Headrests are available in black only; all other colors paint to match.

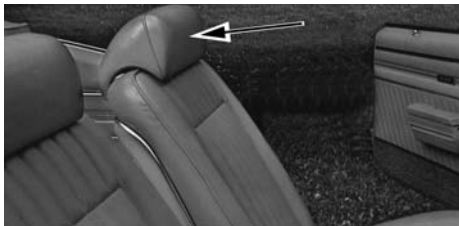

PA174DB 1969 Bucket Seat Headrests, Black (RE) 159.00/pr.
PA174GB 1970-72 Bucket Seat Headrests, Black (RE) 159.00/pr.

These headrests are molded and come complete with posts. Available in black only, all other colors paint to match.
 Note 1: PA174DB-PA174GB will work only on bucket seats.
 Note 2: PA174DB will work on 1968 cars, but will not lock in the extended position.

PA174S 1969-72 Bucket Seat Headrest Covers - GP (RE) . 34.00/pr.
 These replacement headrest covers are pre-sewn and ready to install over the old headrest. Inquire on colors available.
 Comments: Not molded like originals; quality is fair to good.



PA199D

PA199D 1969 Bucket Seat Headrest Locks w/ Escutcheons, Pair (RE) 35.00/pr.

Note: 2 sets required per car.

PA199S 1969 Bucket Seat Headrest Escutcheon (RE).. 10.00/ea.
 This is the escutcheon only.

PA200 1970-72 Bucket Seat Headrest Lock Assembly w/Escutcheon (RE) 10.00/ea.



PA200

MISC. SEAT COMPONENTS



PA184JB

PA184JB 1955-56 Upper Seat Back Stops (RE)..... \$9.00/set
PA184JD 1955-56 Lower Seat Back Bumper (RE)..... 9.00/set



PA184JD



PA184JG

PA184JG 1957 Upper Seat Back Bumper (RE)..... 9.00/ea.
PA185 1964-65 Seat Back Bumper (RE) 2.50/ea.



PA185

The reproduction seat back bumpers have correct size, shape, and include steel insert.



PA186

PA186 1964-77 Seat Back Bumper (GM) 4.50/ea.
 Both PA185 and PA186 have been found on 1964 & '65 models.
 Please check your car and refer to diagrams before placing your order.
PA186J 1965-67 Folding 3rd Seat Rear Bumpers, SW (RE) 3.00/pr.



PA190

PA190 1955-57 Chrome Seat Adjustment Knob (RE) 11.00/ea.
PA192 1959-60 Chrome Seat Adjustment Knob (RE) 23.00/ea.



PA193

This knob also fits '61 Bonneville convertible.
PA193 1961-64 Chrome Seat Adjustment Knob - Exc. Bonneville & GP (RE) 23.00/ea.
PA194 1962-64 Chrome Seat Adjustment Knob - Bonneville & GP w/Bucket Seats (RE) ... 23.00/ea.

Note: Requires two.

PA195 1965 Chrome Seat Adjustment Knob - All (RE) 12.00/ea.
PA195 1966 Chrome Seat Adjustment Knob Bench Seat (RE) 12.00/ea.



PA196

PA196 1967-70 Chrome Seat Adjuster Knob - All (RE) ... 6.00/ea.



PA196C

PA196C 1967-70 Bench Seat Release Knob (RE)..... 6.00/ea.

PA198 1970-77 Black Plastic Seat Adjuster Knob -All (GM) 6.00/ea.



PA199L

PA199L 1967-68 Bucket Seat Release Button and Bezel (RE) \$29.00/ea.



PA201

PA201 1969-72 Bucket Seat Release Button Assembly (RE) 19.00/ea.

This is the chromed plastic button assembly mounted in the seat back. Each assembly comes complete with the spring steel attaching clip.

Comments: Quality of all these reproductions (PA199D through PA201) is excellent.

PA201M 1969-72 Bucket Seat Lock Assembly (RE)..... 119.00/ea.

SEAT MOUNTING BRACKETS & HARDWARE



PA203J

PA203J 1964-72 Bucket Seat Attaching Hardware Kit (AP) 5.50/kit

Contains 6 nuts and 4 bolts, enough for two buckets. 1964-66 cars use 6 nuts and 2 bolts. 1967-72 cars use 4 nuts and 4 bolts.

Comments: Plating is incorrect.



PA204

PA204 1967-72 Bucket Seat Mounting Brackets (RE) 20.00/pr.

These brackets mount the inside bucket seat track to the floor. They are needed when converting from bench to bucket seats or when floors are badly rusted.

PA204A 1967-72 Bucket Seat Bracket Set, 4pc. (RE) 42.00/set

PA204A is a 4-piece set which includes the correct inner & outer brackets.



PA204JL

PA204JL 1969-72 Driver Side Bucket Seat Tracks With Chrome Adjuster Knob, Pair - GP (RE) ... 99.00/pr.

PA204JR 1969-72 Passenger Side Bucket Seat Tracks With Chrome Adjuster Knob, Pair - GP (RE) ... 99.00/pr.

These have the incorrect adjuster knob for late 1970-72. Tracks are gold anodized.

PA205M 1964-72 Rear Seat Bracket Set (RE) 20.00/ea.

SEAT BELTS & COMPONENTS



PA206AA

PA206AA 1955-57 Front Seat Belt (1 person) (RP) \$69.00/ea.

PA206AC 1955-57 Rear Seat Belt (1 person) (RP) 69.00/ea.

With state laws requiring the use of passenger restraints, these original style buckles provide the correct appearance of dealer installed seatbelts. These belts meet all required current federal safety standards. They have chrome-plated fixed anchor ends and satin finished lift up release lid.

Colors available: white, black, red, light blue, medium blue, light turquoise, dark turquoise, dark green, beige, copper, brown and dark gray.



PA206AH

PA206AH 1955-57 Seat Belt Mounting Hardware (1 person) (RP)..... 4.50/ea.

PA206BA 1958-65 Front Seat Belt (1 person) (RP) 65.00/ea.

PA206BC 1958-65 Rear Seat Belt (1 person) (RP) 65.00/ea.

See note under 1955-57 seatbelts. These 1958-65 belts are basically the same belt except the buckle is chrome-plated instead of the satin finish.

Colors available: white, black, red, light blue, medium blue, light turquoise, dark turquoise, dark green, beige, copper, brown, dark gray, maroon, bright red, fawn, dark fawn and medium gold.

PA206AH 1958-65 Seat Belt Mounting Hardware (1 person) (RP)..... 4.50/ea.

PA206BH 1955-65 Seat Belt w/ Mounting Hardware (1 person) Front or Rear (RP) 30.00/ea.

Note: These belts are offered as an inexpensive alternative with a chrome clasp.

Colors available: black, white, dark blue, red and maroon.



PA206D

PA206D 1964-66 Front Seat Belt Retractor, Pair (RE) 25.00/pr.

This is the mid belt accessory retractor. It does not go on the buckle side. Works great with reproduction seat belts and may be used with other years.



PA206GM

PA206GM 1967-72 Seat Belt Buckle Cover- Black, w/ GM Mark of Excellence Decal (RE).. 23.00/ea.

This is a plastic cover like those used on standard interiors.

Seat belt components continue on next page.

Seat belt components continued.



PA206HR



PA206HT

PA206HR 1967-72 Seat Belt Retractor Anchor Bolt (1/2"-13 x13/16") (RE) \$9.50/ea.

PA206HT 1969-72 Inner Seat Belt and Shoulder Strap Anchor Bolt (1/2"-13 x13/16" w/ .556 Shoulder) (RP) 4.00/ea.

This bolt has a shoulder which allows the seat belt to swivel on the bolt.



PA208R



PA211J



PA211K

PA208L 1977 Shoulder Belt Guide Support, LH -GP (RE)..... 10.00/ea.

PA208R 1977 Shoulder Belt Guide Support, RH -GP (RE)..... 10.00/ea.

PA208L & R are the supports that the shoulder belt guide snaps into. Paint to match.

PA211J 1974-76 Shoulder Belt Guide, Black (GM) 6.00/ea.

PA211K 1977 Shoulder Belt Guide, Black (GM) 14.00/ea.

PA211J and PA211K are paint to match.

UNASSEMBLED INNER DOOR PANELS

These unassembled reproduction panels are dielectrically pleated to original specifications and are supplied with cardboard backing and door panel carpeting (mylar inserts are attached when applicable). For colors available for your year, please refer to seat upholstery colors.

Samples must be seen before ordering colored door panels.

Add \$18.00 oversize fee to standard shipping for orders that include front door panels.



1962

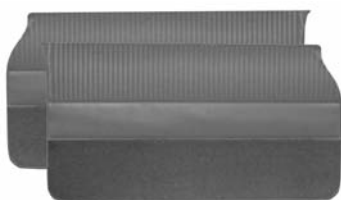

1962 Colors: Black, White, Light Blue, Red, Saddle

PA058A 1962 Inside Front Door and Rear 1/4 Panels - GP (RE) 289.00/set

PA058C 1962 Inside Front Door Panels - GP (RE) 205.00/pr.

PA058D 1962 Inside Rear 1/4 Panels - GP (RE) 94.00/pr.

1963



1963 Colors: Black, White, Dark Blue, Aqua, Red, Saddle

PA060 1963 Inside Front Door and Rear 1/4 Panels - GP (RE) 289.00/set

PA060C 1963 Inside Front Door Panels - GP (RE) 205.00/pr.

PA060D 1963 Inside Rear 1/4 Panels - GP (RE) 94.00/pr.

1964



1964 Colors: Black, White, Dark Blue, Aqua, Red

PA064 1964 Inside Front Door and Rear 1/4 Panels - GP (RE) \$289.00/set

PA064C 1964 Inside Front Door Panels - GP (RE) 205.00/pr.

PA064D 1964 Inside Rear 1/4 Panels - GP (RE) 94.00/pr.

1965

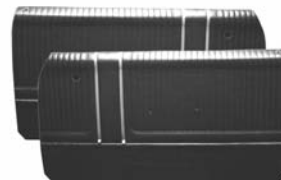

1965 Colors: Black, Parchment, Dark Blue, Aqua, Metallic Red

PA070 1965 Inside Front Door and Rear 1/4 Panels - GP (RE) 289.00/set

PA070C 1965 Inside Front Door Panels - GP (RE) 205.00/pr.

PA070D 1965 Inside Rear 1/4 Panels - GP (RE) 94.00/pr.

PA072 1965 Inside Front Door and Rear 1/4 Panels - 2+2 HT (RE) See Note

PA072B 1965 Inside Front Door and Rear 1/4 Panels - 2+2 CVT (RE) See Note

PA072C 1965 Inside Front Door Panels - 2+2 (RE) See Note

PA072D 1965 Inside Rear 1/4 Panels - 2+2 HT (RE) 94.00/pr.

PA072F 1965 Inside Rear 1/4 Panels - 2+2 CVT (RE) .. 94.00/pr.

Note: 1965 2+2 Front door panels are available in pre-assembled form only (see page 22) while coupe inside rear quarter panels are available only un-assembled. Convertible inside quarter panels can be obtained either way.

PA072P 1965 Inside Front Door and Rear 1/4 Panels - Parisienne HT (RE) 289.00/set

PA072R 1965 Inside Front Door and Rear 1/4 Panels - Parisienne CVT (RE) 289.00/set

PA072S 1965 Inside Front Door Panels - Parisienne (RE) 205.00/pr.

PA072T 1965 Inside Rear 1/4 Panels - Parisienne HT (RE) 94.00/pr.

PA072V 1965 Inside Rear 1/4 Panels - Parisienne CVT (RE) 94.00/pr.

1966



1966 Colors: Black, Parchment, Blue, Aqua, Metallic Red

PA074 1966 Inside Front Door and Rear 1/4 Panels - GP (RE) 289.00/set

PA074C 1966 Inside Front Door Panels - GP (RE) 205.00/pr.

PA074D 1966 Inside Rear 1/4 Panels - GP (RE) 94.00/pr.

PA076 1966 Inside Front Door and Rear 1/4 Panels - 2+2 HT (RE) 289.00/set

PA076A 1966 Inside Front Door and Rear 1/4 Panels - 2+2 CVT (RE) 289.00/set

Unassembled door panels continue on next page.

Unassembled door panels continued.

PA076C	1966	Inside Front Door Panels - 2+2 (RE).....	\$205.00/pr.
PA076D	1966	Inside Rear 1/4 Panels - 2+2 HT (RE)	94.00/pr.
PA076F	1966	Inside Rear 1/4 Panels - 2+2 CVT (RE) ..	94.00/pr.
PA077C	1966	Inside Front Door Panels Bonneville (RE)	365.00/pr.
PA077F	1966	Inside Rear 1/4 Panels Bonneville CVT (RE).....	149.00/pr.

1967



1967 Colors: Black, Parchment, Aqua, Blue, Red, Gold

PA078	1967	Inside Front Door and Rear 1/4 Panels - GP HT (RE)	289.00/set
PA078A	1967	Inside Front Door and Rear 1/4 Panels - GP CVT (RE)	289.00/set
PA078C	1967	Inside Front Door Panels - GP (RE)	205.00/pr.
PA078D	1967	Inside Rear 1/4 Panels - GP HT (RE).....	94.00/pr.
PA078F	1967	Inside Rear 1/4 Panels - GP CVT (RE)....	94.00/pr.
PA079AB	1967	Inside Front Door and 1/4 Panels - Parisienne CVT (RE)	289.00/pr.
PA079AC	1967	Inside Front Door Panels - Parisienne (RE)	205.00/pr.
PA079AF	1967	Inside Rear 1/4 Panels - Parisienne CVT (RE).....	94.00/pr.

PRE-ASSEMBLED INNER DOOR PANELS

These pre-assembled door panels include the basic door panel, a new top rail (upper backing plate), Windowfelt® brand weatherstrip and door lock ferrules.

Samples must be seen before ordering colored door panels.

1962

PA080A	1962	Pre-Assembled Inside Front Door and Rear 1/4 Panels - GP (RE).....	Inquire
PA080C	1962	Pre-Assembled Inside Front Door Panels - GP (RE)	Inquire
PA080D	1962	Pre-Assembled Inside Rear 1/4 Panels - GP (RE)	Inquire

1963

PA082	1963	Pre-Assembled Inside Front Door and Rear 1/4 Panels - GP (RE).....	499.00/set
PA082C	1963	Pre-Assembled Inside Front Door Panels - GP (RE)	299.00/pr.
PA082D	1963	Pre-Assembled Inside Rear 1/4 Panels - GP (RE)	215.00/pr.

1964

PA083	1964	Pre-Assembled Inside Front Door and Rear 1/4 Panels - GP (RE).....	Inquire
PA083C	1964	Pre-Assembled Inside Front Door Panels - GP (RE)	Inquire
PA083D	1964	Pre-Assembled Inside Rear 1/4 Panels - GP (RE)	Inquire

1965

PA084	1965	Pre-Assembled Inside Front Door and Rear 1/4 Panels - GP (RE).....	\$369.00/set
PA084C	1965	Pre-Assembled Inside Front Door Panels - GP (RE)	299.00/pr.
PA084D	1965	Pre-Assembled Inside Rear 1/4 Panels - GP (RE)	Inquire
PA085	1965	Pre-Assembled Inside Front Door and Rear 1/4 Panels - 2+2 HT (RE).....	Inquire
PA085B	1965	Pre-Assembled Inside Front Door and Rear 1/4 Panels - 2+2 CVT (RE).....	499.00/set
PA085C	1965	Pre-Assembled Inside Front Door Panels - 2+2 (RE)	299.00/pr.
PA085D	1965	Pre-Assembled Inside Rear 1/4 Panels - 2+2 HT (RE)	Inquire
PA085F	1965	Pre-Assembled Inside Rear 1/4 Panels - 2+2 CVT (RE)	215.00/pr.

1966

PA086	1966	Pre-Assembled Inside Front Door and Rear 1/4 Panels - GP (RE).....	489.00/set
PA086C	1966	Pre-Assembled Inside Front Door Panels - GP (RE)	299.00/pr.
PA086D	1966	Pre-Assembled Inside Rear 1/4 Panels - GP (RE)	199.00/pr.
PA087	1966	Pre-Assembled Inside Front Door and Rear 1/4 Panels - 2+2 HT (RE).....	489.00/set
PA087B	1966	Pre-Assembled Inside Front Door and Rear 1/4 Panels - 2+2 CVT (RE)	489.00/set
PA087C	1966	Pre-Assembled Inside Front Door Panels - 2+2 (RE)	299.00/pr.
PA087D	1966	Pre-Assembled Inside Rear 1/4 Panels - 2+2 HT (RE)	215.00/pr.
PA087F	1966	Pre-Assembled Inside Rear 1/4 Panels - 2+2 CVT (RE)	215.00/pr.

Add \$18.00 oversize fee to standard shipping for orders that include front door panels.



DOOR PANEL COMPONENTS



PA215

PA215	1964-65	2+2 Door Panel Emblems (RE)	46.00/pr.
--------------	---------	-----------------------------------	-----------

Note: Because of the limited market, PA215 is not die-cast. It is a low-pressure casting and the quality is good.



PA220



PA222



PA220C



PA220D

PA220	1964-77	Door and Quarter Panel Trim Fastener (RE)50/ea.
PA221	1964-77	Door and Quarter Panel Fastener Kit (RE).....	6.00/kit

Note: This kit contains 18 PA220 and 18 original style screws.

PA222	1964-77	Door and Quarter Panel Trim Fastener Grommet (RE).....	.50/ea.
--------------	---------	---	---------

This is the grommet that the trim fastener plugs into. Most cars require 18 pieces.

PA220C	Door Panel Retainer 7/16" Nail Head Style	.50/ea.
PA220D	Oval Door Panel Fastener Grommet50/ea.



PA222J PA222J
Door and Quarter Panel Trim
Removal Tool (AP) \$8.00/ea.



PA225 1960-73 Door Panel Carpeting, 80/20 Loop (RP) 26.00/pr.
PA226 1974-77 Door Panel Carpeting, Cut Pile (RP) 26.00/pr.

Note 1: PA225 & PA226 are 18" x 74" pieces of carpeting which is enough to replace worn carpeting on both door panels. It must be cut to fit. Does not come with vinyl strip.

Note 2: This carpeting can also be used on cars with carpeted kick panels.

PA226V 1960-77 Door Panel Carpet Binding, Black (RE) . 18.00/pr.



PA230K 1975-76 Door Assist Pull Strap Escutcheon Cover
- GP (GM) 4.00/ea.
PA230K 1977 Door Assist Pull Strap Escutcheon Cover
- All (GM) 4.00/ea.

Requires two per strap.



PA231 1965-68 Remote Mirror Control Retainer - FS (RE) 10.00/ea.



PA233J 1970-72 Remote Mirror Control Knob
Escutcheon - GP (RE) 29.00/ea.

PA233J is the chrome bezel that surrounds the mirror control knob.

DOOR PANEL WATER SHIELDS

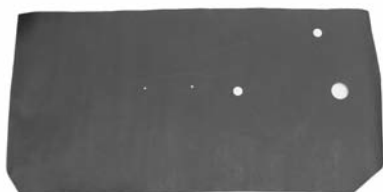

PA228K 1959-60 Plastic Door Panel Water Shields (RE)... 15.00/pr.
PA228F 1961-62 Plastic Door Panel Water Shields (RE)... 15.00/pr.
PA228H 1963-64 Plastic Door Panel Water Shields
- Exc. GP (RE) 15.00/pr.
PA228K 1963-64 Plastic Door Panel Water Shields - GP (RE) 15.00/pr.
PA228N 1965-66 Plastic Door Panel Water Shields (RE)... 15.00/pr.

ARMREST BASES

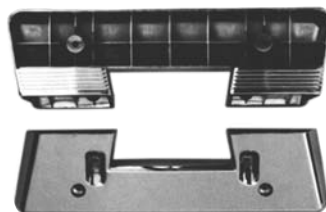

PA255 1960-64 Front Chrome Armrest Bases -
Exc. Bonneville Brougham (APE)..... \$30.00/pr.
PA255 1965-67 Front Chrome Armrest Bases -
Exc. Bonneville & GP (APE) 30.00/pr.

Comments: The finest available - we actually use copper-nickel-chrome plating. Others use the original GM method of vacuum plating which results in yellowing and fading within months (your originals are a perfect example of this problem).

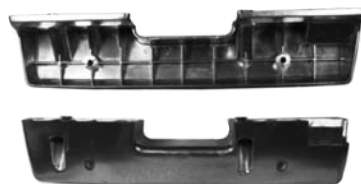

PA256 1965-66 Front Chrome Armrest Bases -
Bonneville & GP (APE) 53.00/pr.

PA256 is now available. Quality is comparable to our highly successful PA255 and PA260 armrest bases.

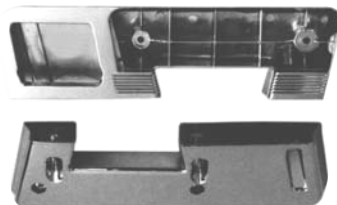

PA260 1960-64 Rear Chrome Armrest Bases -
All 2 Dr. Sedans and All 4 Dr.
Rear Doors (APE) 30.00/pr.

These bases match those found originally on 1960-61 Catalinas, but many originals were not chrome-plated. Paint to match.

PA260 1965-67 Rear Chrome Armrest Bases -
All 2 Dr. Sedans and All 4 Dr.
Rear Doors, Exc. Bonneville (APE) 30.00/pr.

Comments: Excellent—Superior to all others on the market.



PA270L 1968-70 Front Armrest Base, LH - Exc. Bonneville
& GP (RE) 30.00/ea.
PA270R 1968-70 Front Armrest Base, RH - Exc. Bonneville
& GP (RE) 30.00/ea.
PA270L 1968-70 Rear Armrest Base, 4Dr., LH -
Exc. Bonneville & GP (RE) 30.00/ea.
PA270R 1968-70 Rear Armrest Base, 4Dr., RH -
Exc. Bonneville & GP (RE)..... 30.00/ea.

These bases were previously reproduced using reinforced rubber. A new correct plastic reproduction has just been released. Quality is very good.

Colors Available: black, parchment, red, dark green, dark blue.



PA270V

PA270V 1969-70 Front and Rear Chrome Armrest Base Backing Plates- 4Dr. Catalina & Executive (RE).. \$53.00/pr.
These plates were used on some 4-door models.

ARMREST PADS



PA270W

PA270W 1968-69 Rear Armrest Bases, Pads, and Ashtrays - 2dr. HT & 2dr. Sedan (RE) 125.00/set

This set includes the correct ashtrays with the ribbed lid. Available in black only. Paint to match.

Comments: Quality is excellent

PA274 1960-62 Front Armrest Pads (APE) 39.00/pr.

Note: This is the correct thin pad used only in 1960-62.

PA275 1963-64 Front Armrest Pads (APE) 37.00/pr.

PA276 1965-67 Front Armrest Pads- Exc. Bonneville & GP (APE) 37.00/pr.

PA277 1963-64 Rear Armrest Pads- All 2 Dr. Sedans & All 4 Dr. Rear Doors (APE)..... 37.00/pr.

PA278 1965-67 Rear Armrest Pads- All 2 Dr. Sedans & All 4 Dr. Rear Doors Exc. Bonneville) (APE) 37.00/pr.

Note: PA274 through PA278 fit PA255 and PA260 armrest bases only.

These pads are manufactured using the same process as original GM. They use new stamped steel, foam and high-quality vinyl. Refer to seat kits for color availability.

Note: You must see samples for colors other than black.

Comments: One of our finest reproductions.

PA278A 1965-66 Front Armrest Pads - Bonneville & GP (APE)..... 54.00/pr.

These pads are manufactured using the same process as our highly successful PA275 and PA276 front pads. These pads fit PA256.

Note: You must see samples for colors other than black.



PA279

PA279 1968-70 Front Armrest Pads- Exc. Bonneville & GP (APE) 45.00/pr.

PA279 1968-70 Rear Armrest Pads- 4Dr. Exc. Bonneville & GP (APE) 45.00/pr.

PA279 is reproduced using a similar process to GM's original method. They have a steel base, foam core and are vinyl covered using a high tension adhesive rather than staples. Beware of inferior quality injected urethane reproductions.

Colors available: aqua, black, dark blue, dark saddle, ivy gold, mustard gold, teal blue, parchment, red, bright red, pearl, dark green, olive green, jade green, sandalwood, saddle, sienna brown, and white.

Note: You must see samples for colors other than black.

PA279CA 1968-69 Rear Armrest Pads (A-Body) (RE) \$45.00/pr.

These new reproduction pads feature a urethane core wrapped in morrokide madrid-grain vinyl. Base is ABS Plastic. Available in the same colors as PA279.

Quality is very good.

REAR ARMREST STEEL & COVERS



PA295BB

PA295B 1955 Convertible Rear Armrest Panels - Steel (RE) 409.00/pr.

PA295BB 1956-57 Convertible Rear Armrest Panels - Steel (RE) 409.00/pr.

PA295BD 1958 Convertible Rear Armrest Panels - Steel (RE) 409.00/pr.

Note: These are the steel structures that the vinyl rear armrest covers adhere to.

Add \$10.00 oversize fee to standard shipping for PA295B-PA295BD.



PA296 1962 Rear Armrest Covers - GP (RE)..... 72.00/pr.

These covers are a one-piece stitched vinyl like originals. For colors available please refer to armrest pad colors.

Note: You must see samples for colors other than black.

PA297 1965-68 Convertible Rear Armrest Covers (RE)... 72.00/pr.

These covers are two-piece stitched vinyl like originals. For colors available please refer to armrest pad colors.

Note: You must see samples for colors other than black.

PA298 1965-68 Coupe Rear Armrest Covers (RE) 72.00/pr.

ARMREST COMBINATIONS

Note 1: These armrest combinations are an excellent value containing all the parts needed to refurbish your worn armrests.

Note 2: Additional discounts do not apply to armrest combinations.

Note 3: Except for PA286J, PA284 through PA292 use PA255 and PA260 armrest bases only. PA286J uses PA256 bases.

Colors available: aqua, black, dark blue, medium blue, gold, parchment, red, bright red, metallic red, pearl, dark green and white.

You must see samples for colors other than black.



PA286

PA284 1960-62 Front Armrests and Pads (APE) 65.00/set

PA285 1963-64 Front Armrests and Pads (APE) 63.00/set

PA286 1965-67 Front Armrests and Pads - Exc. Bonneville & GP (APE) 63.00/set

PA286J 1965-66 Front Armrests and Pads - Bonneville & GP (APE) 99.00/set

PA287 1963-64 Rear Armrests and Pads- 2 Dr. Sedan & all 4 Dr. Models (APE) ... 63.00/set

Armrest combinations continue on next page.

Armrest combinations continued.

PA288	1965-67 Rear Armrests and Pads - Exc. Bonneville & GP (APE)	\$63.00/set
PA289	1963-64 Rear Armrests, Pads, and Ashtrays- 2 Dr. Sedan & all 4 Dr. Models (APE)	99.00/set
PA290	1965-67 Rear Armrests, Pads, and Ashtrays- Exc. Bonneville & GP (APE)	99.00/set
PA291	1963-64 Front and Rear Armrests, Pads, and Rear Ashtrays- 2 Dr. Sedan & all 4 Dr. Models(APE).....	159.00/set
PA292	1965-67 Front and Rear Armrests, Pads, and Rear Ashtrays- Exc. Bonneville & GP (APE).....	159.00/set



PA310

PA310	1960-67 Rear Ashtrays - All 4 Dr. Models and 2 Dr. Sedans exc. 1964 Bonneville Brougham & 1965-67 Bonneville (APE).....	\$37.00/pr.
--------------	---	-------------

With so many originals badly deteriorated, we've manufactured these ashtrays using stainless steel. Dimensions and luster exhibit our usual high quality.

Comments: Very good to excellent.

ARMREST SCREW



PA281

PA281G

PA281	1960-67 Armrest Base to Door Screw (RP)75/ea.
This replacement screw differs from original since it has 14 threads/inch vs. 10 threads/inch.		
PA281C	1968-70 Armrest Base to Door Screw - Exc. Bonneville & GP (RP)	1.50/ea.
PA281G	1960-70 Armrest Base to Pad Screw (RP)35/ea.
PA297B	Rear Armrest Screws (RE).....	.50/ea.



PA316

PA315	1968-72 Rear Ashtray - All 2 Dr. Models - FS (GM)	63.00/ea.
PA316	1969-72 Rear Ashtray - GP (RE)	33.00/ea.
Note: These GM replacement ashtrays no longer are available with the original ribbed covers.		
PA316C	1971-75 Rear Door Ashtray - 4Dr FS (RE).....	30.00/ea.
PA316C	1973-77 Door Ashtray - GP (RE).....	30.00/ea.

ASHTRAYS



PA300

PA301

PA300	1955-58 Rear Ashtray Cover and Frame- 2 Dr.HT & CVT. (RE)	31.00/ea.
PA301	1955-58 Rear Ashtray Insert for PA300 (RE)	14.00/ea.



PA305

PA306

PA305	1959-67 Rear Ashtray - All 2 Dr. Models w/Ashtray Built Into Armrest (APE)	29.00/pr.
PA306	1959-67 Rear Ashtray Bezel, Fits PA305 (APE)....	10.00/pr.
PA307	1959-67 Rear Ashtray Sets (Includes Two Ashtrays (PA305) and Two Bezels (PA306) (APE)	39.00/pr.

A high-quality reproduction. The bezels are recommended to complement PA305.

Comments: Very good.

These ashtrays and bezels will fit 1965-67 Bonneville and Grand Prix only.

POWER WINDOW & DOOR LOCK SWITCHES



PA235B

PA235B	1964-68 Power Window Switch- LH Door, Exc. 1967 Bonn. & GP (4 button) (RE).....	49.00/ea.
PA235D	1967 Power Window Switch- RH Door, Bonn. & GP (1 button)(GM)	63.00/ea.
PA235B	1969 Power Window Switch- LH Door, All exc. Bonn. & GP (4 button)(RE)	49.00/ea.
PA235H	1969-72 Power Window Switch- RH Door and Rear 1/4 Window - GP (1 button)(GM) .	80.00/ea.
PA235HB	1969-72 Power Window Switch- RH Door and Rear 1/4 Window - GP (1 button)(RE) ...	39.00/ea.
PA235HE	1971-76 Power Window Switch- FS (1 button)(GM)	80.00/ea.
PA235HF	1971-76 Power Window Switch- FS (1 button)(RE).....	39.00/ea.
PA235J	1971 Power Window Switch- LH Door - FS (4 button) (RE)	69.00/ea.
PA235J	1972-74 Power Window Switch- LH Door - Catalina (4 button) (RE)	69.00/ea.
PA235H	1971 Power Window Switch- RH Door and Rear 1/4 Window - FS (1 button) (GM) .	80.00/ea.
PA235H	1972-74 Power Window Switch- RH Door and Rear 1/4 Window - Cat. (1 button)(GM)	80.00/ea.
PA235D	1972-77 Power Window Switch- RH Door and Rear 1/4 Window - All FS exc. Cat. (1 button)(GM)	63.00/ea.
PA237D	1971-72 Power Door Lock Switch - GP (RE).....	59.00/ea.
PA237D	1971 Power Door Lock Switch - FS (RE).....	59.00/ea.
PA237D	1976 Power Door Lock Switch - FS (RE).....	59.00/ea.

ORIGINAL-STYLE ACCESSORY MATS

These mats have been well-received by many collectors of classic Pontiacs. These original-style mats have always been extremely scarce and in some cases ridiculously expensive. Mats are molded using exactly the same design and shape as original. They have proved to be extremely durable and fade-resistant. They are excellent for every day use.

Note 1: Since these mats are the same shape as originals, the rears must be cut for different body styles. This same procedure was used by GM. Please specify what body style you have when ordering.

Note 2: As with any large rubber product, small air pockets or blemishes may be present.

Colors Available: Black, blue, red and off-white. **Colored mats available in full sets only. Add \$15.00 for colored mats.**

Important Note: Our mats are manufactured using an insert for the emblem. These mats are now practically indestructible.

Note: Add \$10.00 oversize fee to standard shipping for accessory mats



PA100

PA100 1956-57 Accessory Mats (RE) \$180.00/set

Note: Although not originally available for 1955 Pontiacs, these mats add a finishing touch for those models.

PA100E 1958 Accessory Mats (RE) Disc.



PA101

PA101 1964-70 Accessory Mats-FS (RE)..... \$120.00/set

Colors Available: Black, blue, red and off-white.



PA102

PA102 1971-72 Accessory Mats-FS (RE)..... 120.00/set

PA102 1969-72 Accessory Mats-GP (RE) 120.00/set

Colors Available: Black, blue, red and off-white.

PA120 1964-70 Front Accessory Mats, Black Only
- FS (RE) 69.00/pr.

PA121 1971-72 Front Accessory Mats, Black Only
- FS (RE) 69.00/pr.

PA121 1969-72 Front Accessory Mats, Black Only - GP(RE) 69.00/pr.

PA123 1964-72 Rear Accessory Mats, Black Only - All (RE) 60.00/pr.



PA100K

PA100K 1961-63 Accessory Mats (RE) 180.00/set

Colors Available: Black, blue, red and off-white.

CARPETED ACCESSORY MATS

To complement our carpet kits, we now offer embroidered carpeted accessory floor mats. These are manufactured by Auto Custom Carpets, the same company that makes our high quality carpets, and are available in the same colors as our carpet. These mats feature OEM style carpeting, embroidered logo (front mats only), Grip-lock non-skid backing, and color-coded vinyl binding. When ordering, please specify loop or cut pile and color.

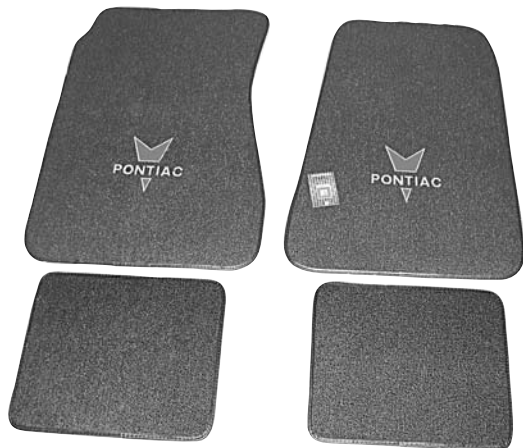

Plain Arrowhead Logo



Indian Head Logo

PA105	1955-73 Arrowhead Logo Carpeted Accessory Mats, Loop - All (AP).....	\$119.00/set
PA105A	1955-73 Indian Head Logo Carpeted Accessory Mats, Loop - All (AP).....	119.00/set
PA105B	1974-77 Arrowhead Logo Carpeted Accessory Mats, Cut Pile - All (AP)	119.00/set
PA105C	1974-77 Indian Head Logo Carpeted Accessory Mats, Cut Pile - All (AP).....	119.00/set
PA105D	1955-73 Plain Arrowhead Carpeted Accessory Mats, Loop - All (AP).....	119.00/set
PA105E	1974-77 Plain Arrowhead Carpeted Accessory Mats, Cut Pile - All (AP).....	119.00/set
PA105NL	1955-73 No Logo Carpeted Accessory Mats, Loop - All (AP).....	89.00/set

Add \$10.00 oversize fee to standard shipping for PA105-PA105E.



CARPET SETS



Important: Please specify model, body style, number of doors, with or without bucket seats and/or console, manual or automatic transmission, with or without power brakes, and color desired. **If you are interested in colors other than black you must request samples for color match prior to ordering.**

Comments: Over the past years, several new companies have started manufacturing 80/20 carpet sets. In keeping with our on-going policy of analyzing all products in our field, we have tested these new carpets. It is our opinion that none compares to the original 80/20 style carpets we have supplied to the Pontiac market for the last twenty-five years. Discount carpets have no place in a fine restoration. Depend on our quality.

Note: All 4-door carpets are a special order. Carpets specifically made for **station wagons** 1958 & later are not available.

PA130	1955-57 Daytona Weave Carpet - 2 Dr. (RE)	\$339.00/set
PA130B	1955-57 Daytona Weave Carpet - 4 Dr. (RE)	339.00/set
PA130D	1955-57 Daytona Weave Carpet - Safari (RE)	339.00/set

Different quality Daytona weave carpets have been available for Chevrolets for years. The supplier of the nation's finest product (a special foam-backed material) has made an excellent reproduction of the 1955-57 carpets to fit the Pontiac floor pan.

This manufacturer has also duplicated the original heel pad. Because of their dedication to quality, we highly recommend this carpet.

Daytona Weave carpet colors available: grey, lt. green, dk. green, lt. blue, med. blue, dk. blue, aqua, bronze, black, red and beige.

PA131	1955-57 Loop Carpet - 2 Dr. (RE)	189.00/set
PA131B	1955-57 Loop Carpet - 4 Dr. (RE)	189.00/set
PA131D	1955-57 Loop Carpet - Safari (RE)	189.00/set
PA132	1958 Lurex Weave Carpet w/Front & Rear Bucket Seats (RE)	Disc.
PA133	1958 Lurex Weave Carpet w/Front Buckets and Std. Rear (RE)	Disc.
PA134	1958 Lurex Weave Carpet w/Bench Seat (RE)	Disc.

Lurex/Trinidad carpets are no longer available.

PA135	1958 Molded Loop Carpet (RE)	189.00/set
--------------	------------------------------------	------------

These carpets are correctly contoured and are an exact fit. They will not have the lurex thread.

PA137	1959 Lurex Weave Carpet - 2 Dr. HT (RE)	Disc.
PA138	1959 Lurex Weave Carpet - CVT (RE).....	Disc.
PA138D	1959 Lurex Weave Carpet - 4 Dr. HT (RE)	Disc.

Lurex/Trinidad carpets are no longer available.

PA139	1959 Molded Loop Carpet (RE)	189.00/set
PA140	1960 Molded Loop Carpet - All (RE).....	189.00/set

Carpet sets continue on next page.

Carpet sets continued.

We now have PA142-PA144 carpets for 1961-64 floor-shift manual transmission cars. Please specify the transmission when ordering.

PA142	1961-64	Molded Loop Carpet - All exc. Bonneville and '63-'64 GP w/Console (RE)	\$189.00/set
PA143	1961-64	Molded Loop Carpet - Bonneville (RE)	189.00/set
PA144	1963-64	Molded Loop Carpet - GP w/Console (RE)	189.00/set
PA145	1965-70	Molded Loop Carpet - FS (RE)	189.00/set
Note: Beware of companies selling less expensive, incorrect Chevrolet B-body carpets. We sell only Pontiac carpets which have the correct extra material up front to meet the firewall pad. Pontiacs are the only GM cars that utilize this extra length.			
PA150	1971-73	Molded Loop Carpet - FS (RE)	149.00/set
PA152	1969-72	Molded Loop Carpet - GP (RE)	149.00/set
PA153	1973	Molded Loop Carpet - GP (RE)	149.00/set
PA154	1974-76	100% Nylon Cut Pile Carpet- FS (RE) ...	149.00/set
PA156	1974-76	100% Nylon Cut Pile Carpet (2 pc.) - GP (RE)	149.00/set
PA157	1977	100% Nylon Cut Pile Carpet (1 pc.) - GP (RE)	149.00/set

Add \$10.00 oversize fee to standard shipping for carpets.



Note: For new **door sill plates** see PF640 - PF655 on page 75.

FLOOR INSULATION

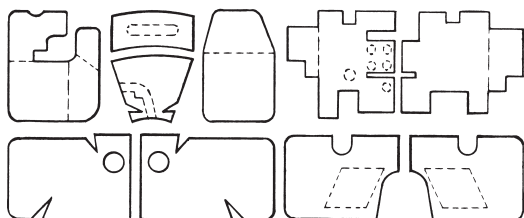

These sets replace the floor insulation under the carpet. Many times upon replacing the carpet you will find the original material cracked and useless.

Comments: The standard kits are made from a heavy rubberized type material. They are manufactured in smaller dove-tailed pieces than the factory's because of shipping problems. Correct floor insulation kits are made of the original paper-backed tar paper material. Paper backed material requires a working temperature above 70° F.

Note: Size and shapes may differ from originals.

Add \$16.00 oversize fee to standard shipping for floor insulation kits.

PA160	1955-57	Standard Floor Insulation Kit (RE)	55.00/set
PA160A	1955-57	Correct Floor Insulation Kit (RE)	69.00/set
PA162	1959-60	Standard Floor Insulation Kit (RE)	55.00/set
PA162A	1959-60	Correct Floor Insulation Kit (RE)	69.00/set
PA163	1961-64	Standard Floor Insulation Kit (RE)	55.00/set
PA163A	1961-64	Correct Floor Insulation Kit (RE)	69.00/set
PA165	1965-70	Standard Floor Insulation Kit - FS (RE) ...	55.00/set
PA165A	1965-70	Correct Floor Insulation Kit - FS (RE)	69.00/set
PA166	1971-76	Standard Floor Insulation Kit - FS (RE) ...	55.00/set
PA166A	1971-76	Correct Floor Insulation Kit - FS (RE)	69.00/set
PA169	1969-72	Standard Floor Insulation Kit - GP (RE) ..	55.00/set
PA169A	1969-72	Correct Floor Insulation Kit - GP (RE)	69.00/set
PA170	1973-77	Standard Floor Insulation Kit - GP (RE) ..	55.00/set
PA170A	1973-77	Correct Floor Insulation Kit - GP (RE)	69.00/set

FLOOR PANS

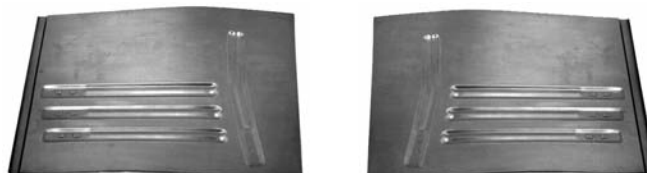

PA810

PA810	1955-57	Front Floor Pans (RE)	\$125.00/ea.
PA811	1955-57	Rear Floor Pans (RP)	125.00/ea.

Rear floor pans may be replaced by taking a pair of front floor pans and reversing them. Several customers have used this process and by trimming the panels were able to complete their floor pan restoration.

Add \$12.00 oversize fee to standard shipping for PA810-PA811.



PA815

PA815	1955-57	Wire Harness Sill Covers, Front - All 2 Dr. (RE)	40.00/pr.
--------------	---------	--	-----------

These are the sheet metal pieces that go under the carpet from the floor to the rocker panel seam to protect the wiring harness.

PA816	1955-57	Wire Harness Sill Covers, Rear -2Dr. Sedan (RE)	21.00/pr.
--------------	---------	---	-----------

PA820	1955-57	Wire Harness Sill Cover Screw Set, 12 Pcs. (RE)	2.50/set
--------------	---------	---	----------

Add \$8.00 oversize fee to standard shipping for PA815-PA816.



PA825L

PA825R

PA825L	1959-60	Rear Seat Riser, LH (RE)	82.00/ea.
PA825R	1959-60	Rear Seat Riser, RH (RE)	82.00/ea.
PA830L	1959-60	Front Floor Pan, LH (RE)	109.00/ea.
PA830R	1959-60	Front Floor Pan, RH (RE)	109.00/ea.
PA831L	1959-60	Rear Floor Pan, LH (RE)	99.00/ea.
PA831R	1959-60	Rear Floor Pan, RH (RE)	99.00/ea.
PA832L	1959-60	Rear Seat Pan, LH (RE)	115.00/ea.
PA832R	1959-60	Rear Seat Pan, RH (RE)	115.00/ea.
PA836L	1961-64	Rear Floor Pan, LH (RE)	72.00/ea.
PA836R	1961-64	Rear Floor Pan, RH (RE)	72.00/ea.
PA850L	1965-70	Front Floor Pan, LH - FS (RE)	95.00/ea.
PA850R	1965-70	Front Floor Pan, RH - FS (RE)	95.00/ea.
PA851L	1965-70	Rear Floor Pan, LH - FS (RE)	99.00/ea.
PA851R	1965-70	Rear Floor Pan, RH - FS (RE)	99.00/ea.
PA854	1965-70	Full Floor Pan Under Rear Seat - FS (RE)	105.00/ea.

Add \$60.00 oversize fee to standard shipping for PA854 and \$20.00 for all other floor pans.





PA859L

- PA859L 1969-72 Floor to Firewall Pan, LH-GP (RE)..... \$49.00/ea.
- PA859R 1969-72 Floor to Firewall Pan, RH-GP (RE) 49.00/ea.
- PA860L 1969-72 Front Floor Pan, LH - GP (RE)..... 59.00/ea.
- PA860R 1969-72 Front Floor Pan, RH - GP (RE) 59.00/ea.
- PA861L 1969-72 Rear Floor Pan, LH - GP (RE)..... 59.00/ea.
- PA861R 1969-72 Rear Floor Pan, RH - GP (RE) 59.00/ea.

Add \$12.00 oversize fee to standard shipping for PA859L&R and \$25.00 for PA860 through PA861R.



- PA862L 1969-72 Full Floor Pan, LH - GP (RE) 89.00/ea.
- PA862R 1969-72 Full Floor Pan, RH - GP (RE)..... 89.00/ea.

Add \$60.00 oversize fee to standard shipping for PA862L and PA862R.



PA862W

- PA862W 1969-72 Full Floor Pan, LH-GP (RE) 109.00/ea.
- PA862X 1969-72 Full Floor Pan, RH-GP (RE)..... 109.00/ea.

These pans are more comprehensive than PA862L & PA862R. PA862W & PA862X include floor to firewall section, the base of the kick panel, top of rocker panel along with half of the transmission tunnel. Under the rear seat is not included. PA862W and PA862X combined, make a complete floor excluding under the rear seat.

Note: PA862W and PA862X must be prepaid and require a \$20.00 boxing fee. **They will be shipped by truck freight. Please inquire regarding shipping costs.**



Truck freight items require a commercial shipping address.



PA864

- PA864 1969-72 Full Floor Pan Under Rear Seat - GP (RE) 169.00/ea.

Add \$35.00 oversize fee to standard shipping for PA864.



PA864DL

- PA864DL 1969-72 Partial Under Seat Rear Floor Pan, LH -GP (RE)..... 82.00/ea.
- PA864DR 1969-72 Partial Under Seat Rear Floor Pan, RH -GP (RE)..... 82.00/ea.

Add \$12.00 oversize fee to standard shipping for PA864DL and PA864DR.



- PA870L 1973-77 Front Floor Pan, LH - GP (RE)..... \$99.00/ea.
- PA870R 1973-77 Front Floor Pan, RH - GP (RE) 99.00/ea.
- PA871L 1973-77 Rear Floor Pan, LH - GP (RE)..... 99.00/ea.
- PA871R 1973-77 Rear Floor Pan, RH - GP (RE) 99.00/ea.

Add \$25.00 oversize fee to standard shipping for floor plans.

FLOOR BRACES



PA880R

- PA880L 1959-60 Front Seat Mounting Bracket, LH (RE)... 79.00/ea.
- PA880R 1959-60 Front Seat Mounting Bracket, RH (RE) .. 79.00/ea.

These brackets weld under the front underseat floor pan. Made from heavy gauge metal, they come complete with cage nuts to bolt the bench seat down securely.

- PA880AL 1959-60 Front Floor Brace, LH (RE) 120.00/ea.
- PA880AR 1959-60 Front Floor Brace, RH (RE) 120.00/ea.
- PA880BL 1959-60 Center Floor Brace, LH (RE) 125.00/ea.
- PA880BR 1959-60 Center Floor Brace, RH (RE)..... 125.00/ea.
- PA880DL 1959-60 Rear Partial Floor Brace End, LH (RE).... 99.00/ea.
- PA880DR 1959-60 Rear Partial Floor Brace End, RH (RE) ... 99.00/ea.

These braces are only the outer ends back by the wheelwells – they measure 20" long.

- PA888AL 1965-70 Front Floor Brace, LH-FS (RE)..... 65.00/ea.
- PA888AR 1965-70 Front Floor Brace, RH-FS (RE) 65.00/ea.
- PA888BL 1965-70 Center Floor Brace, LH-FS (RE)..... 65.00/ea.
- PA888BR 1965-70 Center Floor Brace, RH-FS (RE) 65.00/ea.
- PA888CL 1965-70 Rear Short Floor Brace, LH-FS (RE)..... 39.00/ea.
- PA888CR 1965-70 Rear Short Floor Brace, RH-FS (RE) 39.00/ea.
- PA888DL 1965-70 Rear of Rear Floor Brace, LH-FS (RE) 65.00/ea.
- PA888DR 1965-70 Rear of Rear Floor Brace, RH-FS (RE) 65.00/ea.



PA890

- PA890 1969-72 Front Floor Brace - GP (RE) 99.00/ea.
- PA890A 1969-72 Center Floor Brace - GP (RE) 99.00/ea.
- PA890B 1969-72 Rear Floor Brace - GP (RE) 99.00/ea.

These braces are the finishing touch for your floor problems. Practically every rusted floor has rusted floor braces. These braces are stamped using heavy 12 gauge steel and are ready to be welded in place.

Note: Seat belts attach to the center floor brace.

Add \$16.00 oversize fee to standard shipping for PA890-PA890AB floor braces.



PA890LL

PA890LR

- PA890LL 1969-72 Partial Front Floor Brace, LH -GP (RE)... 59.00/ea.
- PA890LR 1969-72 Partial Front Floor Brace, RH- GP (RE) .. 59.00/ea.
- PA890ML 1969-72 Partial Center Floor Brace, LH- GP (RE) 59.00/ea.
- PA890MR 1969-72 Partial Center Floor Brace, RH- GP (RE) 59.00/ea.

Partial braces start at the inner rocker panel and go approximately 18" in towards the center of the floor. Recommended for applications where the entire brace is not needed.

FLOOR PLUGS & SEALER



PA899



PA899C



PA899P

PA899 1959-77 Floor Drain Plug, Steel (RE) \$4.50/ea.

This is the steel drain plug found in the body floors.

Note: Although not necessary with our reproduction floors, these plugs should be used when authenticity is required.

PA899C 1959-77 Floor Drain Plug, Steel (RE) 4.50/ea.

This style plug with two notches is secured in place by two screws.

PA899P 1969-72 1" Floor Drain Plug, Rubber - GP (RE) .. 3.00/ea.

This plug is found under the rear seat.



PA900

PA900 Seam Sealer, Tan (AP) 15.00/tube

UNDERDASH INSULATION

PA239J 1969-72 Underdash Insulation - GP (RE) 18.00/set

This 3-piece insulation set is a felt-backed black plastic and mounts directly under the dash.

FIREWALL PADS



PA240B



PA249

PA240 1955-56 Firewall Pad (RE) 205.00/ea.
PA240B 1957 Firewall Pad (RE) 205.00/ea.
PA240D 1958 Firewall Pad (RE) 179.00/ea.
PA240F 1959-60 Firewall Pad (RE) 179.00/ea.
PA240H 1961-62 Firewall Pad (RE) 205.00/ea.
PA240J 1963-64 Firewall Pad (RE) 159.00/ea.

PA240-PA240J are molded ABS panels with embossed leatherette grain and jute backing. These panels were made from original molded style cardboard pads and are ready to install. They are black and can be painted to match your interior color. Almost all original pads are either cracked, dried-up or completely gone. This is an excellent replacement.

Add \$16.00 oversize fee to standard shipping for PA240-PA240J.



PA241 1957 Firewall Pad - Rubber (AP) 49.00/ea.

This pad, unlike the original jute-backed molded board, is rubber-faced with a jute backing. It is not original but it does make an inexpensive alternative to PA240B.

PA245 1965-66 Firewall Pad w/o AC (RE) 59.00/ea.
PA245A 1965-66 Firewall Pad w/AC (RE) 59.00/ea.
PA245D 1965-68 Firewall Heater Box Gasket Seal w/o AC (RE) 19.00/ea.
PA247F 1967 Firewall Pad w/o AC (RE) 59.00/ea.
PA247H 1967 Firewall Pad w/AC (RE) 59.00/ea.
PA247J 1968 Firewall Pad (RE) 59.00/ea.



PA248

PA248 1969-72 Firewall Pad w/Clips- GP w/o AC (RE) . \$30.00/ea.
PA248AA 1969-72 Firewall Pad w/Clips- GP w/ AC (RE) 30.00/ea.



PA248AF

PA248AF 1969-72 Molded Firewall Pad w/ Clips- GP w/o AC (RE) 129.00/ea.
PA248AG 1969-72 Molded Firewall Pad w/ Clips- GP w/ AC (RE) 129.00/ea.
PA249 1959-72 Firewall Pad Clip - All (RE)75/ea.

STEERING COLUMN SEALS & PLATE



PA250A

PA250 1955-56 Inner Seal - AT (RE) 10.00/ea.
PA250A 1955-56 Inner Seal - MT (RE) 13.00/ea.
PA251 1957 Inner Seal - AT (RE) 13.00/ea.
PA251A 1957 Inner Seal - MT (RE) 13.00/ea.
PA252 1955-57 Sponge Seal - AT (RE) 13.00/ea.



PA252A

PA252A 1955-57 Sponge Seal - MT (RE) 14.00/ea.
PA253 1958 Inner Seal - AT (RE) 13.00/ea.
PA253B 1958 Sponge Seal - AT (RE) 10.00/ea.
PA253D 1958 Inner Seal - MT (RE) 13.00/ea.
PA253F 1958 Sponge Seal - MT (RE) 10.00/ea.
PA253Z 1969-72 Steering Column Seal - GP (RE) 5.50/ea.

Note: These are the seals which surround the steering column where it goes through the firewall.



PA254

PA254 1969-72 Plastic Steering Column Plate - GP (RE) 22.00/ea.

Comments: PA254 has a glossy finish unlike the originals which had a semi-gloss finish.

Note: PA254 does not come with fasteners.

STEERING COLUMNS

These steering columns are remanufactured original units re-painted black. New ignition switches and turn signal switches are installed. Steering wheel and components not included. Steering Columns carry a limited lifetime mechanical warranty.



- PA340DJ** 1969-70 Floor Shift Tilt Steering Column - GP (RM) \$379.00/ea.
PA340DH 1971-72 Floor Shift Tilt Steering Column - GP (RM) 379.00/ea.
Add \$30.00 oversize fee to standard shipping for steering columns.



STEERING WHEEL COMPONENTS



PA320

- PA320** 1964 Sport Steering Wheel Horn Button Emblem (APE) \$99.00/ea.

Highest quality available. **Beware of low-cost, low-quality reproductions of this part.**



PA321

- PA321** 1964 Sport Steering Wheel Horn Button w/o Rubber Collar (RE) 89.00/ea.

This piece is spun resulting in the hollow center. Once the emblem is inserted the assembly looks the same as original.

Comments: Very good- high cost is due to limited market.



PA321F

- PA321F** 1964 Sport Wheel Horn Button Rubber Collar (RE) 5.00/ea.



PA325

- PA325** 1965-68 Sport Steering Wheel Horn Button Emblem (APE) 37.00/ea.

This emblem sits in the chrome horn button. Practically every original we've seen is cracked or faded.

Comments: Excellent (Attach w/Clear Silicone RTV Sealant).

Note: These reproductions exhibit excellent machine work and chrome.



PA326

- PA326** 1965-66 Good Quality Complete Wood Wheel Horn Button Assembly w/o Switch (RE) 112.00/ea.



PA327

- PA327** 1967 Good Quality Complete Wood Wheel Horn Button Assembly w/o Switch (RE) 112.00/ea.

- PA328** 1968 Good Quality Complete Wood Wheel Horn Button Assembly w/o Switch (RE) 112.00/ea.

These complete assemblies include the emblem, chrome cover and chrome housing.

No further discounts apply to button assemblies

Steering wheel components continue on next page.

TILT & TURN SIGNAL LEVERS



- | | | | |
|---------------|--|-------|-------------|
| | PA699P | PA700 | |
| PA699H | 1964-66 Tilt Wheel Release Lever (RE)..... | | \$15.00/ea. |
| PA699J | 1967-77 Tilt Wheel Release Lever - All (GM)..... | | 10.00/ea. |
| PA699P | 1964-66 Turn Signal Lever w/o Cruise Control w/Tilt Wheel (RE) | | 20.00/ea. |
| PA700 | 1967-72 Turn Signal Lever w/ Cruise Control - GP (GM)..... | | 158.00/ea. |
| PA700 | 1967-76 Turn Signal Lever w/Cruise Control - FS (GM) | | 158.00/ea. |
| PA705 | 1969-75 Turn Signal Lever w/o Cruise - All and '76 FS (RE)..... | | 19.00/ea. |

INTERIORS



PA329

- PA329** 1965-66 Wood Wheel Horn Button Chrome Cover (RE)..... Disc.



PA336

- PA330** 1967 Wood Wheel Horn Button Chrome Cover (RE)..... Disc.

- PA331** 1968 Wood Wheel Horn Button Chrome Cover (RE)..... Disc.

- PA332** 1965-66 Wood Wheel Horn Button Chrome Housing (RE)..... Disc.

- PA333** 1967 Wood Wheel Horn Button Chrome Housing (RE)..... Disc.

- PA334** 1968 Wood Wheel Horn Button Chrome Housing (RE)..... Disc.

- PA336** 1965-66 Wood Wheel Horn Button Collar (RE).. 35.00/ea.

- PA337** 1967 Wood Wheel Horn Button Collar (RE).. 35.00/ea.

- PA338** 1968 Wood Wheel Horn Button Collar (RE).. 35.00/ea.

- PA339** 1969-72 Sport Wheel Horn Button Collar (RE) ... 35.00/ea.

These collars bolt under the wood wheel and finish the transition between the wheel and steering column. Due to increased manufacturing costs, these are now available only in plastic.



PA339D

- PA339D** 1969-72 Sport Wheel Horn Button w/ Lucite (RE) 89.00/ea.



PA339F

- PA339F** 1969-72 Custom Sport Wheel Switch Adapter (RE) 18.00/ea.

Comments: Grain is incorrect. Overall quality is considered good.

Steering wheel components continued.



PA340

PA340 1965-66 Wood Wheel Spoke Inserts (RE)..... \$60.00/set
 These spoke inserts are die-cast and attach directly to the wood wheel spokes. On most wheels these are badly pitted. Quality: Fair to poor.



PA340AP

PA340AP 1965-72 Horn Contact Kit (RP)..... 5.00/kit
 PA340AP fits all 1965-72 wood wheels and 1964-66 standard deluxe wheels.



PA340B

PA340B 1965-72 Steering Wheel Horn Switch (RE)..... 19.00/ea.
 PA340B Applications are as follows: 1965-66 Standard Wheel, 1965-70 Wood Wheel, 1970-72 Formula Wheel, and 1971-72 Custom Sport padded wheel.



For cancel cams see page 111

SPORT WOOD WHEELS (BARE)



PA340R

PA340R 1965-66 Sport Wood Wheel (RE)..... \$309.00/ea.
PA340S 1967 Sport Wood Wheel (RE)..... 309.00/ea.
PA340V 1969-70 Sport Wood Wheel (RE)..... 289.00/ea.
 PA340R-PA340V are the bare steering wheels only. No components included.

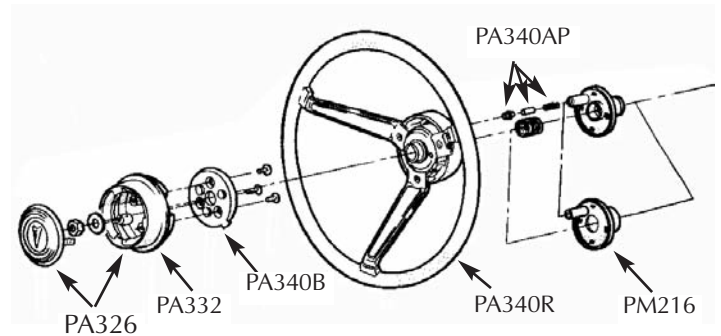

Typical 1965-66 wood wheel

COMPLETE SPORT WOOD WHEEL ASSEMBLIES



PA340F

1965-66 Wheel comments: The color of the grain is a shade lighter and not as defined as original. Spoke insert edges were originally brushed whereas these are polished. Chrome work is fair to good. Overall quality is considered to be "Good".

1967 Wheel comments: The color of the grain is a shade lighter and not as defined as original. Spoke inserts are welded to the wheel as opposed to being held in place by 4 rivets originally. Spoke inserts are slightly thicker than GM's and chrome work is fair to good. Overall quality is considered to be "Good".

PA340F 1965-66 Complete Sport Wood Wheel Assembly (RE)..... 429.00/ea.
PA340J 1967 Complete Sport Wood Wheel Assembly (RE)..... 429.00/ea.
PA340P 1969-70 Complete Sport Wood Wheel Assembly (RE)..... 429.00/ea.

No further discounts apply to steering wheel assemblies.

OWN OTHER PONTIACS?

Call or visit www.amesperf.com for your Free:



**1967-1981
 Firebird
 Trans Am
 Formula
 Catalog**

or

**1964-1977
 GTO
 Lemans
 Tempest
 1971-1974
 Ventura**



FORMULA WHEEL & COMPONENTS



Correct Molded Reproduction
PA342

Leather Reproduction
PA342AC

PA342 1970-71 Molded Formula Wheel (RE) \$219.00/ea.

PA342 does not include collar, cover, or other components. This is the wheel only. Outer wheel foam rim circumference is 3 1/4".

Quality: Fair to good.

PA342AC 1970-71 Leather Formula Wheel Black w/ Black Spokes (AP) 199.00/ea.

The Lecarra© reputation has always appealed to those customers that appreciate original style Formula wheels with real leather construction. They look great, feel great, and all original Formula components fit these wheels. Thickness of the outer rim is slightly larger than original. The inside spoke dimensions are the same as original GM.



PA342G



PA342P



PA342R



- PA342G** 1970-71 Formula Wheel Center Cap w/o Emblem (RE)..... 25.00/ea.
PA342P 1970-71 Formula Wheel Switch Adapter (RE) 22.00/ea.
PA342R 1970-71 Formula Wheel Collar W/Screws (RE) .. 55.00/ea.
PA340B 1969-71 Formula Wheel Horn Switch (RE) 19.00/ea.

STEERING WHEEL PULLER



PA342T

PA342T 1955-77 Steering Wheel Puller (AP)..... 22.00/kit

This is a must for removing your steering wheel. Using this will prevent damaging the steering wheel or column.

STEERING WHEEL RESTORATION



PA342TV

PA342TV 1955-77 POR 15 Steering Wheel Restoration Kit (AP) 89.00/kit

This kit contains all materials and instructions needed to refurbish cracked or broken wheels to show quality.

GRANT© CLASSIC SERIES WHEELS

Note 1: PA343 through PA343M have a real wood rim.

PA343A through PA343N have a black urethane foam rim.

Note 2: Grant wheel assemblies come complete with all attaching hardware and horn switch. Horn center cap comes complete with a Pontiac arrowhead emblem.

Quality: Very good. Excellent value.



- PA343** 1955-63 Grant Custom Wood Wheel Assembly, All (AP) \$189.00/kit
PA343B 1964-66 Grant Custom Wood Wheel Assembly, Non Tilt Wheel (AP)..... 189.00/kit
PA343D 1964-66 Grant Custom Wood Wheel Assembly, Tilt Wheel (AP) 189.00/kit
PA343H 1967-68 Grant Custom Wood Wheel Assembly, All (AP) 189.00/kit
PA343M 1969-77 Grant Custom Wood Wheel Assembly, All (AP) 189.00/kit



- PA343A** 1955-63 Grant Custom Deluxe Wheel Assembly, All (AP) 135.00/kit
PA343C 1964-66 Grant Custom Deluxe Wheel Assembly, Non Tilt Wheel (AP)..... 135.00/kit
PA343F 1964-66 Grant Custom Deluxe Wheel Assembly, Tilt Wheel(AP) 135.00/kit
PA343J 1967-68 Grant Custom Deluxe Wheel Assembly, All (AP) 135.00/kit
PA343N 1969-77 Grant Custom Deluxe Wheel Assembly, All (AP) 135.00/kit.



**Thank you
for shopping with
Ames Performance**

"The Nations Largest Supplier of Pontiac Parts"

GAUGES & LENSES



PA317

PA317	1968	In-dash Tach 5100 RPM Redline.....	\$145.00/ea.
PA317A	1968	In-dash Tach 5500 RPM Redline.....	145.00/ea.
PA318	1969	In-dash Tach 5100 RPM Redline - GP (RE).....	145.00/ea.
PA318A	1969	In-dash Tach 5500 RPM Redline - GP (RE).....	145.00/ea.
PA319	1970-72	In-dash Tach 5100 RPM Redline - GP (RE).....	145.00/ea.
PA319A	1970-72	In-dash Tach 5500 RPM Redline - GP (RE).....	145.00/ea.

Note 1: These tachs look identical to the original units when installed and carry a multi-year warranty (**units must not be altered or opened**). Wiring harness is included.

Note 2: Although originally incorrect, we offer a 5500 RPM tach for those people requesting a tach to complement their high-performance engines.



PA319H

PA319F		5" Diameter Super Tach W/Shift Light & Memory W/Chrome Housing (AP).....	169.00/ea.
PA319G		3 3/4" Diameter Tach W/Chrome Housing (AP).....	79.00/ea.
PA319H		2 1/16" Diameter Three Gauge Package (AP).....	99.00/ea.



PA323

PA323	1969-71	Rally Gauge Cluster - GP - for Cars w/o Original Rally Gauges (RE).....	279.00/asm.
PA323A	1969-71	Rally Gauge Cluster - GP - for Cars w/ Original Rally Gauges (RE).....	279.00/asm.
PA324	1972	Rally Gauge Cluster - GP - for Cars w/o Original Rally Gauges (RE).....	279.00/asm.
PA324A	1972	Rally Gauge Cluster - GP - for Cars w/ Original Rally Gauges (RE).....	279.00/asm.

Note: Initial quality looks good. These are not made exactly like originals, however they will mount like originals and the face appearance looks very nice.



PA443NB

PA443NB	1969-72	Dash Instrument Cluster Lens - GP (RE)	55.00/ea.
----------------	---------	--	-----------

DASH PAD RELATED



PA920



PA918



PA940

PA918		Dash Pad, Nylon Attaching Inserts (RP)	\$1.50/ea.
PA920	1957	Dash Pad, Black - Paint to Match (RE) ..	620.00/ea.
PA921	1958	Dash Pad, Black - Paint to Match (RE) ..	620.00/ea.

Made from OEM thermo-form dash vinyl and molded closed cell high density polyethylene foam, these pads are an excellent reproduction. The '57 is made with studs along the bottom edge and a haircell grain texture very close to original. The '58 has the factory original Seville grain texture. Both are unconditionally guaranteed against defects in workmanship and cracking for as long as you own your car. These pads are available in black (paint to match) and are drop-shipped directly from manufacturer.

PA930	1963-64	Dash Cover - Bonneville & GP (AP).....	85.00/ea.
--------------	---------	--	-----------

PA930 is a molded plastic cover that fit over your existing dash pad. It exhibits correct texture, contoured, and fit and has a limited lifetime warranty. Excellent alternative for dash recovering. Black only. Paint to match

Add \$40.00 oversize fee to standard shipping for dash pads & covers.



PA940	1969-72	Underdash Wiring Harness Clip Set 2pc (RE)	6.50/ea.
--------------	---------	--	----------

GLOVE BOXES & COMPONENTS



PA550	1955-56	Glove Box (RE).....	22.00/ea.
PA551	1957	Glove Box, w/o AC (RE).....	22.00/ea.
PA551A	1957	Glove Box, w/AC (RE).....	22.00/ea.
PA552	1958	Glove Box (RE).....	22.00/ea.
PA553	1959-60	Glove Box (RE).....	22.00/ea.
PA554	1961-62	Glove Box (RE).....	22.00/ea.
PA555	1963-64	Glove Box w/o AC (RE).....	22.00/ea.
PA556	1963-64	Glove Box w/AC (RE).....	22.00/ea.
PA557	1965-66	Glove Box w/AC, w/o (A.T.C.) (RE).....	22.00/ea.
PA558	1965-66	Glove Box w/AC, w/A.T.C. (RE).....	22.00/ea.
PA559	1965	Glove Box w/o AC (RE).....	22.00/ea.
PA559A	1966	Glove Box w/o AC (RE).....	22.00/ea.
PA560	1967-68	Glove Box w/o AC - exc. GP (RE).....	22.00/ea.
PA561	1967-68	Glove Box w/AC - exc. GP (RE).....	22.00/ea.
PA561	1967-68	Glove Box - GP (RE).....	22.00/ea.
PA562	1969-70	Glove Box - exc. GP (RE).....	Inquire
PA563	1971-72	Glove Box w/o AC - exc. GP (RE).....	Inquire
PA564	1971-72	Glove Box w/AC - exc. GP (RE).....	Inquire
PA565	1969-72	Glove Box - GP (RE).....	22.00/ea.

Glove box cardboard is die-cut, stapled and ready for installation.

Comments: Very good.



PA568

PA568		Glove Box Light (RE).....	18.00/ea.
--------------	--	---------------------------	-----------

This kit includes bulb, socket, switch and necessary wiring to install this glove box light. Attaches to existing dash harness and is same as original. Excellent quality.



PA595

PA610

PA590	1955-58	Glove Box Lock w/Late-Style Key (NOS).....	\$29.00/ea.
PA591	1955-58	Glove Box Lock w/Original-Style Key (NOS).....	35.00/ea.
Note: These glove box locks do not have chromed bezels. For correct appearance you must use your original bezel.			
PA592	1959-60	Glove Box Lock w/Late-Style Key (NOS)	19.00/ea.
PA593	1959-60	Glove Box Lock w/Original-Style Key (NOS).....	24.00/ea.
PA594	1961-62	Glove Box Lock w/Late-Style Key (NOS)	20.00/ea.
PA595	1961-62	Glove Box Lock w/Original-Style Key (NOS).....	23.00/ea.
PA596	1963-64	Glove Box Lock w/Late-Style Key (NOS)	20.00/ea.
PA597	1963-64	Glove Box Lock w/Original-Style Key (NOS).....	25.00/ea.
PA598	1965-66	Glove Box Lock w/Late-Style Key (NOS).....	Disc.
PA599	1965-66	Glove Box Lock w/Original-Style Key (NOS).....	25.00/ea.
PA600	1967	Glove Box Lock w/Late-Style Key (NOS).....	20.00/ea.
PA601	1967	Glove Box Lock w/Original-Style Key (NOS).....	23.00/ea.

PA602	1968	Glove Box Lock w/Late-Style Key (NOS).....	Disc.
PA603	1968	Glove Box Lock w/Original-Style Key (NOS).....	\$25.00/ea.
PA604	1969	Glove Box Lock w/Original-Style Key (NOS).....	29.00/ea.

Note: PA604 glove box lock does not have the chrome bezel. For correct appearance you must use your original bezel.

PA606	1970-77	Glove Box Lock w/Original-Style Key (NOS).....	19.00/ea.
PA610	1955-58, 1961-62 & 67	Glove Box Lock Retainer (RE).....	6.50/ea.
PA565T	1970-72	Glove Box Lock Nut (RE).....	7.00/ea.

Note: Sets of locks using the same key configuration are available on page 9.

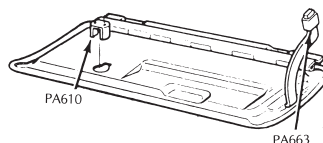

		PA653D	PA660
PA650	1955-58	Glove Box Door Bumpers (RE).....	2.00/pr.
PA653	1959-60	Glove Box Door Bumpers (RE).....	2.00/pr.
PA653D	1959-62	Glove Box Door Grommet 1 3/4" x 5/8" (RE).....	7.50/ea.
PA654	1961-62	Glove Box Door Bumpers (RE).....	2.00/pr.
PA660	1963-67	Glove Box Door Bumpers (RE).....	2.00/pr.
PA661	1968-76	Glove Box Door Bumpers - FS (GM)....	2.00/pr.
PA662	1969-77	Glove Box Door Bumpers - GP (RE).....	2.00/pr.
PA663		Glove Box Stop (GM).....	3.00/ea.

We have found that this stop was used on many different Pontiacs.

WOOD DASH INSERTS

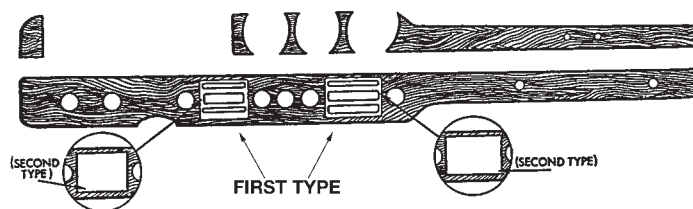

PA401

PA402

PA399	1960	Wood Dash Insert w/o rear speaker - Bonneville - 3 Pc.- Unstained (RE).....	\$28.00/ea.
PA399A	1960	Wood Dash Insert w/o rear speaker - Bonneville - 3 Pc. - Stained (RE).....	35.00/ea.
PA399C	1960	Wood Dash Insert w/ rear speaker - Bonneville - 3 Pc. - Unstained (RE).....	28.00/ea.
PA399D	1960	Wood Dash Insert w/rear speaker - Bonneville - 3 Pc. - Stained (RE).....	35.00/ea.
PA400	1963-64	Wood Dash Inserts, MT or Console Shift AT - Bonneville & GP - 5 Pc. - Unstained (RE).....	28.00/ea.
PA400A	1963-64	Wood Dash Insert, MT or Console Shift AT - Bonneville & GP - 5 Pc.- Stained (RE).....	35.00/ea.
PA400	1964	Wood Dash Insert, MT or Console Shift AT - 2+2 - 5 Pc. - Unstained (RE).....	28.00/ea.
PA400A	1964	Wood Dash Insert, MT or Console Shift AT - 2+2 - 5 Pc. - Stained (RE).....	35.00/ea.
PA401	1963	Wood Dash Insert, Column Shift AT - Bonneville & GP - 4 Pc. - Unstained (RE).....	28.00/ea.
PA401A	1963	Wood Dash Insert, Column Shift AT - Bonneville & GP - 4 Pc. - Stained (RE).....	35.00/ea.
PA401B	1964	Wood Dash Insert, Column Shift AT - 2 +2, GP & Bonneville - 5 Pc. - Unstained (RE).....	28.00/ea.
PA401C	1964	Wood Dash Insert, Column Shift AT - 2+2, GP & Bonneville - 5 Pc. - Stained (RE).....	35.00/ea.
PA402	1965	Wood Dash Insert, Type I- Bonneville & GP - Unstained (RE).....	55.00/ea.
PA402A	1965	Wood Dash Insert, Type 1- Bonneville & GP - Stained (RE).....	65.00/ea.
PA402C	1965	Wood Dash Insert, Type 2- Bonneville & GP - Unstained (RE).....	55.00/ea.
PA402D	1965	Wood Dash Insert, Type 2- Bonneville& GP - Stained (RE).....	65.00/ea.

When ordering '65 dashes, use diagrams to determine which type you need.

Add \$5.00 oversize fee to standard shipping for PA402 through PA402D.



PA404	1966	Wood Dash Insert, w/ or w/o AC - Bonneville, 2+2 & GP - Unstained (RE).....	28.00/ea.
PA404A	1966	Wood Dash Insert, w/ or w/o AC - Bonneville, 2+2 & GP - Stained (RE).....	35.00/ea.

Note: PA400 through PA404A come complete with dash and steering wheel inserts.

Dash inserts continue on next page.

WOOD CONSOLE INSERTS

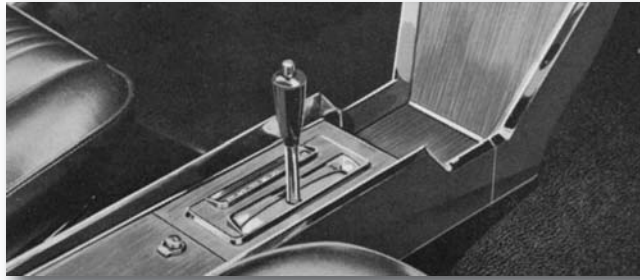

PA406	1963-64	Wood Console Shifter Plate Insert, AT - Bonneville & GP - Unstained (RE)	\$11.00/ea.
PA406A	1963-64	Wood Console Shifter Plate Insert, AT - Bonneville & GP - Stained (RE)	14.00/ea.
PA407	1965-66	Wood Console Insert, AT - Bonneville & GP - Unstained (RE)	28.00/ea.
PA407A	1965-66	Wood Console Insert, AT - Bonneville & GP - Stained (RE)	35.00/ea.
PA408	1965-66	Wood Console Insert, MT - Bonneville & GP - Unstained (RE)	28.00/ea.
PA408A	1965-66	Wood Console Insert, MT - Bonneville & GP - Stained (RE)	35.00/ea.

WOOD DASH AND CONSOLE COMBINATIONS

PA410	1963-64	Wood Dash and Console Shifter Plate Inserts, AT - Bonneville & GP - Unstained (RE)	36.00/ea.
PA410A	1963-64	Wood Dash and Console Shifter Plate Inserts, AT - Bonneville & GP - Stained (RE)	47.00/ea.
PA412	1965	Wood Dash and Console Inserts, Type 1, AT - Bonneville & GP - Unstained (RE)	79.00/ea.
PA412A	1965	Wood Dash and Console Inserts, Type 1, AT - Bonneville & GP - Stained (RE)	92.00/ea.
PA412B	1965	Wood Dash and Console Inserts, Type 1, MT - Bonneville & GP - Unstained (RE)	79.00/ea.
PA412C	1965	Wood Dash and Console Inserts, Type 1, MT - Bonneville & GP - Stained (RE)	92.00/ea.
PA412D	1965	Wood Dash and Console Inserts, Type 2, AT - Bonneville & GP - Unstained (RE)	79.00/ea.
PA412E	1965	Wood Dash and Console Inserts, Type 2, AT - Bonneville & GP - Stained (RE)	92.00/ea.
PA412F	1965	Wood Dash and Console Inserts, Type 2, MT - Bonneville & GP - Unstained (RE)	79.00/ea.
PA412G	1965	Wood Dash and Console Inserts, Type 2, MT - Bonneville & GP - Stained (RE)	92.00/ea.

Add \$5.00 oversize fee to standard shipping for PA412-PA412G. 

PA414	1966	Wood Dash and Console Inserts, AT - Bonneville & GP - Unstained (RE)	54.00/ea.
PA414A	1966	Wood Dash and Console Inserts, AT - Bonneville & GP - Stained (RE)	67.00/ea.
PA414B	1966	Wood Dash and Console Inserts, MT - Bonneville & GP - Unstained (RE)	54.00/ea.
PA414C	1966	Wood Dash and Console Inserts, MT - Bonneville & GP - Stained (RE)	67.00/ea.

Note 1: Save money by purchasing wood dash and console inserts together.
 Note 2: Dash inserts are real walnut veneer, available either unstained or pre-stained in medium walnut. Inserts do not have aluminum backing and are usually cemented over existing material.
 Comments: Very good—nice die-work. Only difference from original is thickness.

VINYL DASH INSERTS



The following dashes were originally available in two designs. Catalina, 2+2, Ventura, and Executive use vinyl walnut wood grain inserts while Bonneville and GP use vinyl, elm-burl grain inserts.

PA420	1967	Vinyl Dash Insert, w/o AC, Column Shift AT - Catalina, 2+2, & Executive (RE)	\$21.00/ea.
PA420A	1967	Vinyl Dash Insert, w/AC, Column Shift AT - Catalina, 2+2, & Executive (RE)	21.00/ea.
PA420B	1967	Vinyl Dash Insert, w/o AC, MT or Console Shift AT - Catalina, 2+2, & Executive (RE)	21.00/ea.
PA420C	1967	Vinyl Dash Insert, w/AC, MT or Console Shift AT - Catalina, 2+2, & Executive (RE)	21.00/ea.
PA421	1967	Vinyl Dash Insert w/o AC, Column Shift AT - Bonneville & GP (RE)	27.00/ea.
PA421A	1967	Vinyl Dash Insert w/AC, Column Shift AT - Bonneville & GP (RE)	27.00/ea.
PA421B	1967	Vinyl Dash Insert w/o AC, Floor Shift AT - Bonneville & GP (RE)	27.00/ea.
PA421C	1967	Vinyl Dash Insert w/AC, Floor Shift AT+ Bonneville & GP (RE)	27.00/ea.

Note: PA421 through PA421C are made from a reproduction elmwood burl grain material that is not an exact match to original. The size and color of the swirls are close, however, the detail is slightly blurred.



PA423A

PA423	1968	Vinyl Dash Insert, w/o AC, Column Shift AT - Catalina, Ventura, & Executive (RE).....	\$21.00/ea.
PA423A	1968	Vinyl Dash Insert, w/AC, Column Shift AT - Catalina, Ventura, & Executive (RE).....	21.00/ea.
PA423B	1968	Vinyl Dash Insert, w/o AC, MT or Console Shift AT - Catalina, Ventura, & Executive (RE).....	21.00/ea.
PA423C	1968	Vinyl Dash Insert, w/AC, MT or Console Shift AT - Catalina, Ventura, & Executive (RE).....	21.00/ea.
PA424	1968	Vinyl Dash Insert, w/o AC, Column AT- Exc. Grand Prix, Burl Grain (RE).....	25.00/ea.
PA424A	1968	Vinyl Dash Insert, with AC, Column AT- Exc. Grand Prix, Burl Grain (RE).....	25.00/ea.
PA424B	1968	Vinyl Dash Insert, w/o AC, Floor Shift- Exc. Grand Prix, Burl Grain (RE).....	25.00/ea.
PA424C	1968	Vinyl Dash Insert, w/ AC, Floor Shift- Exc. Grand Prix, Burl Grain (RE).....	25.00/ea.
PA426B	1969-70	Vinyl Dash Insert, w/o AC, Floor Shift- Grand Prix, Burl Grain (RE).....	25.00/ea.
PA426C	1969-70	Vinyl Dash Insert, w/AC, Floor Shift- Grand Prix, Burl Grain (RE).....	25.00/ea.

Note: PA424 through PA426C are made from a reproduction elmwood burl grain material that is not an exact match to original. The size and color of the swirls are close, however the detail is slightly blurred.

The following console inserts were available in two designs. Catalina, 2+2, Ventura, and Executive use vinyl walnut wood grain inserts while Bonneville and Grand Prix used elm burl grain inserts.

VINYL CONSOLE INSERTS

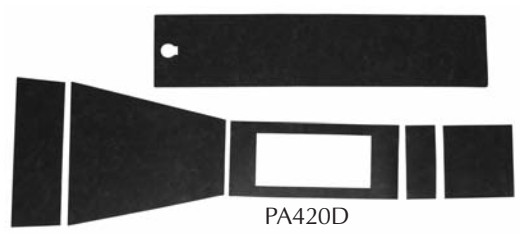

PA420D



PA437A

PA420D	1967-68	Vinyl Console Insert, AT - Bonneville (RE).....	\$27.00/ea.
PA423M	1967-68	Vinyl Console Insert - Burlwood Grain, AT - Grand Prix (RE).....	29.00/ea.
PA432	1967-68	Vinyl Console Insert - Walnut Grain, AT - Catalina, 2+2, Ventura, & Executive (RE).....	27.00/ea.
PA433	1967-68	Vinyl Console Insert - Walnut Grain, 4 Sp. - Catalina, 2+2, Ventura, & Executive (RE).....	27.00/ea.
PA433A	1967-68	Vinyl Console Insert - Burlwood Grain, 4 Sp. - Grand Prix (RE).....	27.00/ea.
PA433H	1967-68	Vinyl Console 8-Track Insert w/ console - Walnut Grain - Catalina, 2+2, Ventura, & Executive (RE).....	18.00/ea.

This is the piece that surrounds the 8-track on '67-'68 full size consoles.

Note: The "Select," "Volume," "Tone" and "Balance" print is not available. These inserts will be blank.

PA437A	1976	Vinyl Console Door Insert - Grand Prix (RE).....	9.00/ea.
---------------	------	--	----------

COMBINATION VINYL DASH & CONSOLE INSERTS

PA440	1967	Vinyl Dash and Console Inserts, w/o AC, AT - Catalina, 2+2, and Executive (RE).....	\$46.00/ea.
PA440A	1967	Vinyl Dash and Console Inserts, w/ AC, AT - Catalina, 2+2, and Executive (RE).....	46.00/ea.
PA440B	1967	Vinyl Dash and Console Inserts, w/o AC, MT- Catalina, 2+2, and Executive (RE).....	46.00/ea.
PA440C	1967	Vinyl Dash and Console Inserts, w/ AC, MT - Grand Prix & Bonneville(RE).....	46.00/ea.
PA440G	1967	Vinyl Dash and Console Inserts, w/AC, MT - Catalina, 2+2, and Executive (RE).....	54.00/ea.
PA441	1968	Vinyl Dash and Console Inserts, w/o AC, AT - Catalina, Ventura, and Executive (RE).....	46.00/ea.
PA441A	1968	Vinyl Dash and Console Inserts, w/ AC, AT - Catalina, Ventura, and Executive (RE).....	46.00/ea.
PA441B	1968	Vinyl Dash and Console Inserts, w/o AC, MT - Catalina, Ventura, and Executive (RE).....	46.00/ea.
PA441C	1968	Vinyl Dash and Console Inserts, w/ AC, MT - Catalina, Ventura, and Executive (RE).....	46.00/ea.

Note: Save money by purchasing vinyl dash and console inserts together.

DASH KNOBS & COMPONENTS

INTERIORS



PA446D

PA446D 1969-72 Switch Retainer Clip (RE) \$5.00/ea.

This clip was used to hold the following switches in the dash: 1969 Power antenna switch; 1969-71 convertible top switch; 1969-71 SV rear power window switch; 1969-72 Defogger switch; 1969 Rear speaker reverb switch; and 1969-70 Power flow vent motor switch.



PA446FJ

PA446FJ 1955-68 Odometer Trip Meter Knob (RE) 4.00/ea.

This knob measures 1/8" ID 7/16" OD x 1/2" tall. Black rubber.



PA446JK

PA446JK 1969-70 Heater Control Knobs - FS (GM)..... 4.50/ea.



PA446JL

PA446JL 1969-70 Heater Control Knob - FS (RE) 2.00/ea.



PA446KL

PA446KK 1968 Ignition Bezel Nut - FS (RE) 11.00/ea.

PA446KK is a less expensive alternative to PA446KL.

PA446KL 1968 Ignition Bezel Nut - FS (RE) 17.00/ea.

PA446KL Quality: Excellent.

See the Electrical Section for Ignition Switches.



PA447B

PA447A 1967-70 Chrome Dash Knob Bezels w/White Letters - FS (RE)..... 19.00/set

PA447A 1969-72 Chrome Dash Knob Bezels w/White Letters - GP (RE) 19.00/set

PA447B 1967-70 Chrome Dash Knob Bezels w/Black Letters - FS (RE)..... 19.00/set

PA447B 1969-72 Chrome Dash Knob Bezels w/Black Letters - GP (RE) 19.00/set

Note 1: PA447A and PA447B bezels were used from 1967 to 1972. Certain bezels will not be used on later cars. This set of five bezels contains "LIGHTS," "WIPER," "LIGHTER" and radio bezels "TONE" and "SELECT."

Note 2: The "SELECT" bezel is used with AM radios only. The "WIPER" bezel is used in 1967-68 only.

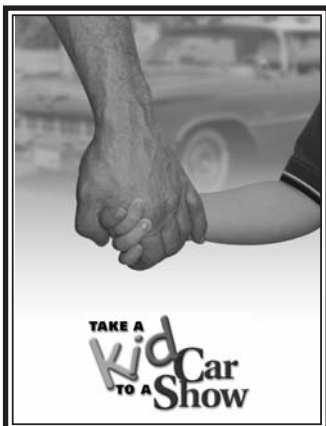

PA448A

PA448A 1967-70 Chrome Speaker Bezel w/White Letters - FS (RE)..... \$5.00/ea.

PA448A 1971-72 Chrome Speaker Bezel w/White Letters - GP (RE) 5.00/ea.

PA448B 1967-70 Chrome Speaker Bezel w/Black Letters -FS (RE) 5.00/ea.

PA448B 1971-72 Chrome Speaker Bezel w/Black Letters - GP (RE) 5.00/ea.

Note: PA448A and PA448B have the word "SPEAKER" printed on them with arrows denoting "R" and "F." You must check your particular application since AM-FM stereo radios used "Balance" instead of "Speaker."

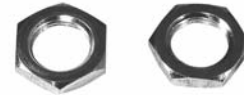

PA448R

PA448R 1963-77 Radio Bezel Retaining Nuts, PR 5.00/pr.

This chrome knob is an excellent reproduction that fits both the volume and select controls on your radio.



PA447BR

PA447BR 1965 Die Cast Chrome Dash Knob (RE) 14.00/ea.

PA447BS

PA447BS 1966 Die Cast Chrome Dash Knob (RE) 14.00/ea.

PA448C

Now available are these die-cast reproductions of the originals.

Quality: Excellent.

PA447C 1966 Dash Knobs, Plastic (RE) 12.00/set

Note: PA447C contains 2 radio knobs and the headlight knob. These are plastic knobs whereas originals were chromed pot metal. However, once installed, appearance is excellent.

PA448C 1967-70 Chrome Radio Control Knob - FS (RE) 5.00/ea.

PA448C 1969-72 Chrome Radio Control Knob - GP (RE) 5.00/ea.

PA447D 1967-70 Dash Knobs - FS (RE) 15.00/set

PA447D 1969-72 Dash Knobs - GP (RE) 15.00/set

Note: PA447D contains 2 radio knobs and headlight knob.



PA47FN PA447FM PA447G

PA447FN 1965 Diecast Headlight Knob and Shaft (RE). 19.00/ea.

PA447FM 1966 Diecast Headlight Knob and Shaft (RE). 19.00/ea.

PA447G 1967-70 Headlight Knob and Shaft - FS (RE)..... 19.00/ea.

PA447G 1969-72 Headlight Knob and Shaft - GP (RE)..... 19.00/ea.



PA448J

PA448J 1965-67 AM-FM Radio Face Decal (RE) \$9.00/ea.
 This decal can refurbish your faded or marred dash face simply and effectively.



PA448JD

PA448JD 1963-66 AM-FM Slide Bar (RE)..... 20.00/ea.
 This is the chrome bar on the radio face used to select desired radio band.
 Radios and other components can be found in the electrical section.

CIGARETTE LIGHTERS & COMPONENTS



PA447L



PA447M

PA447K 1959 and 1964-65 Cigarette Lighter (NOS)..... Inquire
PA447L 1966 Cigarette Lighter (RE) 15.00/ea.
PA447M 1967-70 Cigarette Lighter - FS (RE)..... 15.00/ea.
PA447N 1969-72 Cigarette Lighter - GP (RE)..... 15.00/ea.

Note: These lighter use the Rochester style elements. Some cars (usually '69 models) used a different style Casco element. These Casco style lighters were ejected by a stainless steel collar. Please be sure your original is the same as the photo above.



PA447NB



PA447ND



PA447NE

PA447N Cigarette Lighter Element (Rochester) (AP) Disc.
 This element fits PA447K through PA447M.
PA447NB Cigarette Lighter Element (Casco) (AP).. 10.00/ea.
PA447ND Rochester Lighter Receptacle (RE) 25.00/ea.
PA447NE Rochester Lighter Receptacle Retainer (RE) 9.00/ea.



PA447NF

PA447NF Lighter Housing, w/Retainer (Casco Only) (RP)..... 12.00/ea.

Please refer to the write-up below PA447M to distinguish which style lighter you have. This housing fits Casco only.

CONVERTIBLE TOP SWITCH & BEZEL



PA449F

PA449F 1958 Convertible Top Switch (RP) \$79.00/ea.
 Note: This is a replacement switch that customers have successfully used without modification.
PA449J 1966 Convertible Top Switch (RE)..... 79.00/ea.



PA449JH

PA449JH 1966 Convertible Top Switch Bezel w/Knob (RE)..... 30.00/ea.

Comments: Bezel is low-pressure casting.

PA449JP 1969-70 Convertible Top Switch (RP) 69.00/ea.
 Note: Bezel is different from original equipment. It is stainless, not die-cast chrome like original.



PA449JP

POWER ANTENNA SWITCH & MISCELLANEOUS BEZELS



PA449KH

PA449KH 1964-66 Power Antenna Switch (RE) 75.00/ea.



PA449KK

PA449KK 1964-65 Power Antenna Switch Bezel w/Knob (RE)..... 29.00/ea.
PA449KM 1966 Power Antenna Switch Bezel w/Knob (RE)..... 29.00/ea.



REVERB & SPEAKER BEZELS



PA449KP

PA449KP 1964-65 Reverb Switch Bezel w/Knob (RE) 29.00/ea.
PA449KR 1966 Reverb Switch Bezel w/Knob (RE) 29.00/ea.
PA449KX 1964-65 Speaker Switch Bezel w/Knob (RE)..... 29.00/ea.
PA449KY 1966 Speaker Switch Bezel w/Knob (RE)..... Inquire

Comments: Bezels are low pressure castings.

DASH VENTS



PA450J 1963-77 Chrome Lap Cooler A/C Vent Deflector (RE)..... \$24.00/ea.

PA450J is plastic unlike the early diecast originals.



PA450JC 1963-64 Center Dash AC Vent Deflector (RE)..... 25.00/ea.
PA450JC 1967-69 Center Dash AC Vent Deflector (RE)..... 25.00/ea.

Note: 1 required. **For AC Cars only.** Made in plastic. This deflector is located above the climate control panel.

INSTRUMENT PANEL SCRIPT



PA571 1955 "Star Chief" Instrument Panel Script (APE) 29.00/ea.
PA571C 1955 "Pontiac" Instrument Panel Script (RE).... 18.00/ea.



PA572 1956 "Star Chief" Instrument Panel Script (APE) 29.00/ea.



PA573 1957 "Star Chief" Instrument Panel Script (APE) 29.00/ea.

This is the script which says Star Chief on the passenger side of the instrument panel. All of these reproductions are manufactured in chrome plated plastic (originally PA571 was plastic while PA572 and PA573 were a very brittle zinc alloy).



PA573B 1957 "Pontiac" Instrument Panel Script (RE).. 34.00/ea.



PA574 1957 "Bonneville" Instrument Panel Script (RE) 34.00/ea.



PA574B 1959 Front Speaker Grille Emblem, "Star Chief" Gold Plated (RE)..... 34.00/ea.
PA574D 1959 Front Speaker Grille Emblem, "Bonneville" Gold Plated (RE)..... 34.00/ea.

PA573B through PA574D are low pressure castings.

CONSOLE COMPONENTS



PA348J 1969 4 Speed Console Shift Bezel - GP (RE) .. \$55.00/ea.



PA355 1962-64 Console Courtesy Lamp Lens (APE)..... 9.00/ea.

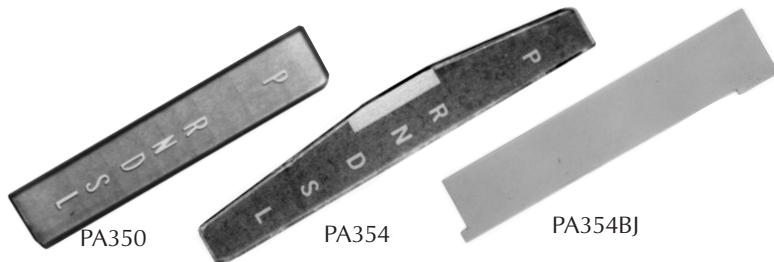

PA350 1965-66 Automatic Console Selector Insert (APE) 8.00/ea.
PA354 1969-72 Automatic Console Selector Insert - GP (APE)..... 8.00/ea.
PA354BJ 1973 Automatic Console Selector Insert Backing Plate - GP (RE)..... 7.00/ea.



PA356 1962-64 Console Compartment Box (RE)..... 16.00/ea.
 Note: Fits 4-speed only.
PA357 1965-68 Console Compartment Box (RP)..... 16.00/ea.

While original boxes were injected plastic, this box is a flocked lined cardboard.

Comments: Not original but nice replacement.

PA358A 1969 Console Door -GP (RE)..... 48.00/ea.
PA358B 1970-72 Console Door -GP (RE)..... 48.00/ea.



PA359J 1963-68 Console Compartment Light (RE-RP).... 18.00/ea.
 This is the one-piece switch light assembly mounted inside the console compartment. The switch is activated by the console door. Wire lead is 29" long and can be spliced into existing harness.

Console components continue on next page.

Console components continued.



PA360 1965-66 "421" Console Emblem (RE) Disc.



PA360A 1967-68 "428" Console Emblem (RE) \$26.00/ea.
PA360AC 1969-72 "Model J" Console Emblem (RE) 23.00/ea.
PA360B 1969-72 "Model SJ" Console Emblem (RE) 23.00/ea.

Note: PA360 through PA360B are not die-cast, they are low pressure castings. Overall quality is good.



PA370 1965-66 Vacuum Gauge Base (RE) 27.00/ea.

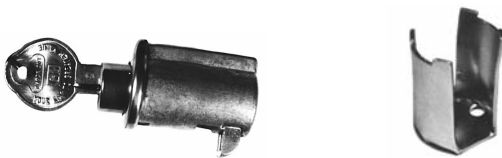

PA361 1962-64 Console Lock w/2 Late-Style Keys (NOS) 22.00/ea.
PA361A 1962-64 Console Lock w/2 Original-Style Keys (NOS) 25.00/ea.
PA362 1965-68 Console Lock w/2 Late-Style Keys (NOS) 20.00/ea.
PA362A 1965-66 Console Lock w/2 Original-Style Keys (NOS) 23.00/ea.
PA363A 1967-68 Console Lock w/2 Original-Style Keys (NOS) 23.00/ea.



PA364 1969-72 Console Lock w/2 Keys, Black Bezel - GP (NOS) 22.00/ea.
PA364A 1969-72 Console Lock w/2 Keys, Chrome Bezel - GP (NOS) 43.00/ea.

Lock pawl is not included with PA364 or PA364A. You must use your original.

PA365 1962-68 Console Lock Retainer w/ Screw (RE) ... 6.50/ea.



PA665 1962-68 Console Bumpers (GM) 8.50/pr.
PA663 1962-64 Console Door Stop (GM) 3.00/ea.
PA668 1969-77 Console Bumpers - GP (RE) 3.00/pr.

KICK PANELS & COMPONENTS



PA750 1955 Forward Cowl Kick Panel w/o AC (RE) \$16.00/pr.
PA751 1956 Forward Cowl Kick Panel w/o AC (RE) 16.00/pr.
PA752 1957 Forward Cowl Kick Panel w/o AC (RE) 16.00/pr.
PA753 1958 Forward Cowl Kick Panel w/o AC (RE) 16.00/pr.
PA754 1959 Forward Cowl Kick Panel w/o AC - Catalina (RE) 16.00/pr.
PA755 1959 Forward Cowl Kick Panel w/o AC - Bonneville (RE) 16.00/pr.
PA756 1960 Forward Cowl Kick Panel w/o AC - Catalina (RE) 16.00/pr.
PA757 1960 Forward Cowl Kick Panel w/o AC - Bonneville (RE) 16.00/pr.
PA757A 1960 Forward Cowl Kick Panel w/ AC - Bonneville (RE) 16.00/pr.
PA758 1961-62 Forward Cowl Kick Panel w/o AC (RE) 16.00/pr.
PA758D 1961-62 Forward Cowl Kick Panel w/ AC (RE) 16.00/pr.
PA759 1963-64 Forward Cowl Kick Panel w/o AC - Bonneville 16.00/pr.
PA762B 1969-72 Kick Panels w/AC - GP (RE) 65.00/pr.

PA759 panels are bare cardboard w/o carpeting. Carpeting may be purchased separately. See PA225. PA750 through PA762B come in black and are paint to match.

PA763N 1969-72 Kick Panel Insulation - GP (RE) 6.00/pr.
PA764N 1969-72 Kick Panel Flapper Seals - GP (RE) 8.00/pr.



PA780 1966 Kick Panel Vent Knobs (RE) 5.50/ea.
PA781 1967-68 Kick Panel Vent Knobs (RE) 5.50/ea.
PA782 1969-72 Kick Panel Vent Knobs, 4 Required (A-body) (RE) 6.00/ea.

These knobs come ready to install with correct hole diameter. Comments: Good to very good.



PA790 1969-72 Upper Dash Side Vent Cable with Knob, All exc. AC, LH or RH- GP (RE) 35.00/ea.
PA792 1969-72 Lower Kick Panel Vent Cable with Knob All exc. AC, LH or RH- GP (RE) 35.00/ea.
PA794 1969-72 Kick Panel Control Cable Clip, All Exc. AC- GP (RE) 1.50/ea.

CARDBOARD PACKAGE TRAYS



INTERIORS

PA455	1955-57	Cardboard Package Tray- 2 Dr. and 4 Dr. Sedan (RE)	\$15.00/ea.	PA461BB	1965	Cardboard Package Tray - 2 Dr. HT, Bonneville (RE)	\$25.00/ea.
PA455A	1955-57	Cardboard Package Tray - 2 Dr. and 4 Dr. HT (RE).....	15.00/ea.	PA461	1965-66	Cardboard Package Tray - 2 Dr. and 4 Dr. Sedan, 4 Dr. HT, Catalina (RE).....	25.00/ea.
PA456	1958	Cardboard Package Tray - All exc. Bonneville (RE)	25.00/ea.	PA461A	1965-66	Cardboard Package Tray - 2 Dr. HT, Catalina (RE)	25.00/ea.
PA457	1959-60	Cardboard Package Tray - 2 Dr. and 4 Dr. Sedan (RE)	25.00/ea.	PA461A	1966	Cardboard Package Tray - 2 Dr. HT, Bonneville (RE)	25.00/ea.
PA457A	1959-60	Cardboard Package Tray - 2 Dr. HT (RE)	25.00/ea.	PA461C	1965-67	Cardboard Package Tray - GP (RE).....	25.00/ea.
PA457B	1959-60	Cardboard Package Tray - 4 Dr. HT (RE)	25.00/ea.	PA462	1967-68	Cardboard Package Tray - 2 Dr. and 4 Dr. Sedan (RE)	25.00/ea.
PA458	1961-62	Cardboard Package Tray - 2 Dr. and 4 Dr. Sedan, 4 Dr. HT (RE)	25.00/ea.	PA462A	1967-68	Cardboard Package Tray - 2 Dr. HT, exc. GP (RE).....	25.00/ea.
PA458A	1961	Cardboard Package Tray - 2 Dr. HT (RE)	25.00/ea.	PA462B	1967-68	Cardboard Package Tray - 4 Dr. HT (RE)	25.00/ea.
PA459A	1962	Cardboard Package Tray - 2 Dr. HT (RE)	25.00/ea.	PA462C	1968	Cardboard Package Tray - GP (RE).....	25.00/ea.
PA459A	1963-64	Cardboard Package Tray - 2 Dr. HT, exc. GP (RE).....	25.00/ea.	PA463	1969-70	Cardboard Package Tray - 4 Dr. HT (RE)	25.00/ea.
PA460	1963-64	Cardboard Package Tray -4 Dr. HT (RE)	25.00/ea.	PA463A	1969-70	Cardboard Package Tray - 2 Dr. HT, exc. GP (RE).....	25.00/ea.
PA460C	1963-64	Cardboard Package Tray - GP (RE).....	25.00/ea.	PA464	1969-70	Cardboard Package Tray - GP (RE).....	25.00/ea.
PA461AA	1965-66	Cardboard Package Tray - 2 Dr. and 4 Dr. Sedan, 4 Dr. HT -Bonneville (RE) .	25.00/ea.	PA465	1971-72	Cardboard Package Tray - GP (RE).....	25.00/ea.
				PA468A	1971-72	Cardboard Package Tray - 2 Dr. HT exc. GP (RE).....	25.00/ea.
				PA468J	1974	Cardboard Package Tray - 4 Dr. Sedan (RE)	25.00/ea.

These trays fit between the rear seat and the rear window and are ready for installation. They are die-cut and 1959-up models come with a vinyl strip and foam rubber padding.

When ordering, specify year, model, body style, and color desired.

Colors available: Black, red, med. blue, dk. blue, aqua, green, brown, saddle, tan, gold, and maroon.

Jute padding is the insulation that goes between the package tray and body bracing. Usually original jute is rotten, causing unnecessary noise and chatter.

If you would like jute padding, please specify in your order by adding a "J" to the end of the part number. It is available for an additional \$10.00.

GM used two styles of package trays. The cardboard style has a stippled appearance without a covering. The mesh package tray uses cardboard covered with a coarse mesh material. The mesh tray gives your interior a more luxurious appearance and comes with hidden rear speaker holes as illustrated below.

Comments: Both types of package trays are of very good quality.

Please inquire concerning package trays not listed here. New patterns are constantly becoming available.

Add \$18.00 oversize fee to standard shipping for Package Trays. 

MESH PACKAGE TRAYS

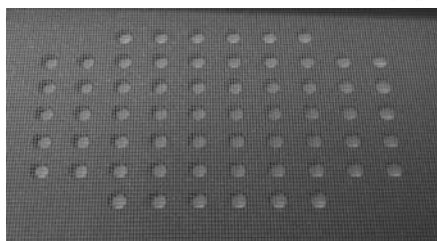

MESH PACKAGE TRAY MATERIAL WITH SPEAKER HOLES.

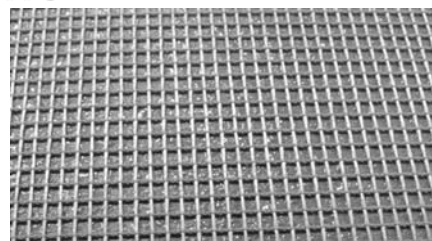

CLOSE-UP OF MESH DETAIL.

PA469Y	1958	Mesh Package Tray - All exc. Bonneville (RE)	\$45.00/ea.	PA473	1963-64	Mesh Package Tray - 2 Dr. and 4 Dr. HT (RE).....	\$45.00/ea.
PA470	1959-60	Mesh Package Tray - 2 Dr. and 4 Dr. Sedan (RE)	45.00/ea.	PA473C	1963-64	Mesh Package Tray - GP (RE)	45.00/ea.
PA470A	1959-60	Mesh Package Tray - 2 Dr. HT (RE)	45.00/ea.	PA474AA	1965-66	Mesh Package Tray - 2 Dr. and 4 Dr. Sedan, 4 Dr. HT - Bonneville & Starchief (RE).....	45.00/ea.
PA470B	1959-60	Mesh Package Tray - 4 Dr. HT (RE)	45.00/ea.	PA474BB	1965	Mesh Package Tray - 2 Dr. HT - Bonneville, & Starchief (RE)	45.00/ea.
PA471	1961-62	Mesh Package Tray - 2 Dr. and 4 Dr. Sedan, 4 Dr. HT (RE)	45.00/ea.	PA474	1965-66	Mesh Package Tray - 2 Dr. and 4 Dr. Sedan, 4 Dr. HT, Catalina(RE).....	45.00/ea.
PA471A	1961	Mesh Package Tray - 2 Dr. HT (RE)	45.00/ea.	PA474A	1965-66	Mesh Package Tray - 2 Dr. HT, Catalina(RE).....	45.00/ea.
PA472A	1962	Mesh Package Tray - 2 Dr. HT (RE)	45.00/ea.				
PA472A	1963-64	Mesh Package Tray - 2 Dr. HT exc. GP (RE).....	45.00/ea.				

Package trays continue on next page.

Package trays continued.

PA474A	1966	Mesh Package Tray - 2 Dr. HT, Bonneville (RE)	\$45.00/ea.
PA474C	1965-66	Mesh Package Tray - GP (RE)	45.00/ea.
PA474D	1967	Mesh Package Tray - GP (RE)	45.00/ea.
PA475	1967-68	Mesh Package Tray - 2 Dr. and 4 Dr. Sedan (RE)	45.00/ea.
PA475A	1967-68	Mesh Package Tray - 2 Dr. HT exc. GP (RE)	45.00/ea.
PA475B	1967-68	Mesh Package Tray - 4 Dr. HT (RE)	45.00/ea.
PA475C	1968	Mesh Package Tray - GP (RE)	45.00/ea.
PA476	1969-70	Mesh Package Tray - 4 Dr. HT, FS (RE) .	45.00/ea.
PA476A	1969-70	Mesh Package Tray - 2 Dr. HT, exc. GP (RE)	45.00/ea.
PA477	1969-70	Mesh Package Tray - GP (RE)	45.00/ea.
PA478	1971-72	Mesh Package Tray - GP (RE)	45.00/ea.
PA480A	1971-72	Mesh Package Tray - 2 Dr. HT, exc. GP (RE)	45.00/ea.

Please inquire concerning the availability of 1971-up full-size package trays. New patterns are constantly becoming available.

If you would like jute padding, please specify in your order by adding a "J" to the end of the part number. It is available for an additional \$10.00.

Add \$18.00 oversize fee to standard shipping for Package Trays.

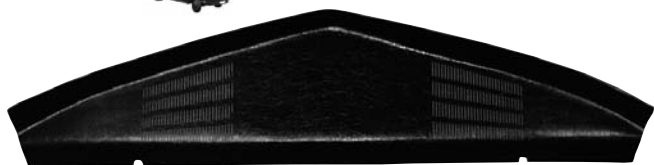

PA485A

PA485	1973-77	Molded Package Tray - GP w/o Speaker Holes (RE)	109.00/ea.
PA485A	1973-77	Molded Package Tray - GP w/ Speaker Holes (RE)	159.00/ea.

These trays are molded ABS panels with embossed leatherette grain. These plastic package trays are duplicated from original molded style cardboard trays, and are ready to install. They are black and can be painted to match your interior color. Many originals are cracked or deteriorated by the sun. This is an excellent reproduction.

Add \$12.00 oversize fee to standard shipping for PA485 and PA485A.



PA711

PA711	1966-72	Rear Speaker Grille - All (RE).....	19.00/ea.
--------------	---------	-------------------------------------	-----------

TRIM ADHESIVE



PA498K

PA498K		Aerosol Trim Adhesive (AP)	14.00/ea.
---------------	--	----------------------------------	-----------

Aerosol paints cannot be shipped by air or outside the Continental United States.

HEADLINER SOUND DEADENER

PA545J	1955-77	Headliner Sound Deadener (RP).....	17.00/ea.
---------------	---------	------------------------------------	-----------

This is the material glued to the roof and used as an insulation and sound deadener. These are not reproductions of the original, but a lighter material that works equally well.

HEADLINERS

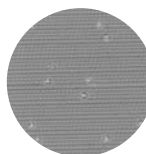

PERFORATED

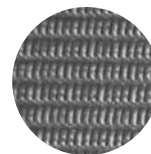

RIBBED

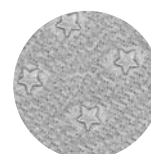

STAR PATTERN

If you do not see your particular headliner listed, please call because we can virtually make all headliners from 1955-77 including station wagons. There are just too many different listings to show all. Please inquire on price and availability.

Note: When ordering your headliner please specify year, body style #, model, color, and type of fabric. Pontiac used many different headlining materials. We have patterns and colors available for almost all body styles. Please inquire. Because of the large number of different headliners used, we stock only the most common. Please allow additional shipping time on special order headliners.

When ordering colors other than black, sample verification is required. Please call for samples of available colors.

PA520	Headliner (RE).....	Inquire
--------------	---------------------	---------

PA520 is universal part number used for any headliner that is not listed below. Price and availability will vary with model year and body style - please inquire. We will need the body style number from the data plate on your car prior to ordering.

PA522	1961	Headliner (Star Pattern) - 2 Dr. HT (RE) .	\$99.00/ea.
PA523	1961	Headliner (Star Pattern) - Sedans (RE)....	99.00/ea.
PA524	1961	Headliner (Star Pattern) - 4 Dr. HT (RE) .	99.00/ea.
PA525	1962-64	Headliner (Star Pattern) - 2 Dr. HT, Exc. 63-64 GP (RE)	99.00/ea.
PA525D	1962-64	Headliner (Star Pattern) - Catalina, 2 Door Sedan (RE)	149.00/ea.
PA526	1963-64	Headliner (Star Pattern) - GP (RE)	99.00/ea.
PA527	1964	Headliner (Ribbed) - GP (RE).....	99.00/ea.
PA528	1963-64	Headliner (Star Pattern) - 4 Dr. HT (RE) .	99.00/ea.
PA529	1963-64	Headliner (Star Pattern) - 4 Dr. Sedan (RE)	109.00/ea.
PA530	1965-66	Headliner (Perforated) - 2 Dr. HT, Exc. GP (RE)	99.00/ea.
PA531	1965-67	Headliner (Perforated) - GP (RE)	99.00/ea.
PA535	1967-68	Headliner (Perforated) - 2 Dr. HT, Exc. GP (RE)	99.00/ea.
PA536	1968	Headliner (Perforated) - GP (RE)	99.00/ea.
PA540	1969-72	Headliner (Perforated) - GP (RE)	99.00/ea.
PA542	1969-70	Headliner (Perforated) - FS (RE)	99.00/ea.

Most headliners come complete with "ear muffs" (cardboard-covered sections behind the 1/4 window) and enough material to cover sunvisors. The star pattern material is an exact match to original and is considered an excellent reproduction. The perforated material is extremely close to original for '65 & later interiors.

Colors: Star pattern comes in black, white, silver, lt. blue, med. blue, aqua and red.

Perforated pattern comes in black, white, sandalwood, buckskin, red, maroon, green, light blue, dark blue, and medium and blue. Samples available on request.

Other materials are available in various original colors. Samples available on request.



PA544H

PA544H	1967-72	Headliner Bow Clip, Each (RE).....	4.00/ea.
---------------	---------	------------------------------------	----------

Note: These clips are used to attach the headliner bows to the roof. Number used varies by year.

SUNSHADES & COMPONENTS

INTERIORS



Comments: These are reproductions of the sunvisor assemblies that become soiled and faded with age. The visor will mount directly into your existing sunshade support.

Note: The sunvisors are available in the same colors as our headliners and armrest pads. Samples are available upon request. When ordering please specify year, model, body style, material and color desired.

If you do not see your particular model listed, please call because new patterns are constantly becoming available.

PA670	1955-58	Sunshade Assembly - HT (RE)	\$99.00/pr.
PA670A	1955-58	Sunshade Assembly - CVT (RE)	99.00/pr.
PA670D	1959-60	Sunshade Assembly, Star Vinyl - HT (RE)	Disc.
PA670E	1959-60	Sunshade Assembly - CVT (RE)	99.00/pr.
PA670J	1961	Sunshade Assembly, Star Vinyl - HT (RE)	Disc.
PA670K	1961-62	Sunshade Assembly - CVT (RE)	99.00/pr.
PA670P	1962-63	Sunshade Assembly, Star Vinyl - HT (RE)	Disc.
PA670R	1963	Sunshade Assembly - CVT (RE)	99.00/pr.
PA670RB	1964	Sunshade Assembly, Star Vinyl - HT (RE)	99.00/pr.
PA670Z	1964	Sunshade Assembly, Ribbed Vinyl - GP (RE)	99.00/pr.
PA670S	1964	Sunshade Assembly - CVT (RE)	99.00/pr.
PA671B	1965-68	Sunshade Assembly, Perforated Vinyl - HT (RE)	99.00/pr.
PA671D	1965	Sunshade Assembly - CVT (RE)	99.00/pr.
PA671F	1966-69	Sunshade Assembly - CVT (RE)	99.00/pr.
PA671J	1969	Sunshade Assembly, Perforated Vinyl - GP (RE)	79.00/pr.
PA671R	1970-72	Sunshade Assembly - CVT (RE)	99.00/pr.
PA671S	1970	Sunshade Assembly, Perforated Vinyl - GP (RE)	79.00/pr.
PA671SA	1971-72	Sunshade Assembly, Perforated Vinyl - GP (RE)	79.00/pr.
PA672B	1973-75	Sunshade Assembly - CVT (RE)	99.00/pr.
PA672J	1973-77	Sunshade Assembly, Perforated Vinyl - GP (RE)	89.00/pr.



PA680

PA680	1955-58	Sunshade Supports- exc. CVT (RE)	36.00/pr.
PA680A	1955-57	Sunshade Supports- CVT (RE)	Disc.
PA680B	1955-57	Convertible Sunshade Support Mounting Screws - Stainless Steel (6 pcs. w/ washers) (RE)	3.00/set
PA684	1960-63	Sunshade Supports -All exc. CVT (RE) ..	46.00/pr.
PA684A	1961-64	Sunshade Supports- CVT (RE)	179.00/pr.



	PA686		PA688
PA686	1965-68	"Best Quality" Sunshade Support LH or RH- exc CVT (RE).....	\$26.00/ea.
PA686	1969-72	"Best Quality" Sunshade Support LH or RH- GP (RE).....	26.00/ea.

Comments: Quality of PA686 is now very good to excellent-much better than GM

PA687	1965-68	"Fair Quality" Sunshade Support LH or RH - exc CVT (GM).....	112.00/ea.
PA687	1969-72	"Fair Quality" Sunshade Support LH or RH - GP (GM).....	112.00/ea.

Comments: PA687 exhibits a poor-quality finish. We suggest using only if using GM is a must.

PA688		Sunshade Support Screw (Fits PA684 & PA687) (GM)	4.00/ea.
--------------	--	---	----------

Note: This is the screw that clamps the support to the visor shaft.

PA689	1971-72	Sunshade Support, LH or RH - FS Exc. CVT (GM).....	Disc.
PA689	1973-77	Sunshade Support, LH or RH - All Exc. CVT (GM).....	Disc.



	PA695		PA698		PA699
PA692	1965-76	Sunshade Support Sleeves - FS (GM)			2.50/pr.
PA695	1969-77	Sunshade Support Sleeves - GP (GM) ...			8.00/pr.
PA698	1959-62	Sunshade Grommets (APE)			5.50/pr.
PA699	1963-72	Sunshade Grommets - All (GM)			11.00/pr.



PA669T

PA669T	1955-58	Sunshade Assembly Chrome Ends (RE).	15.00/set
---------------	---------	-------------------------------------	-----------

Note: Requires 1 set per car.

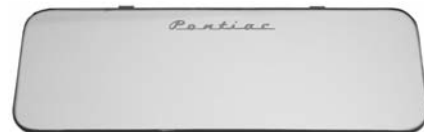

PA395

PA395	1955-77	Visor Vanity Mirror (Clip-On Style w/Pontiac Script) (10" x 3 1/2") (APE)	32.00/ea.
PA397K	1974-77	Vanity Mirror (Push-In Stud Style) (7 1/8" x 3 3/8") (RE).....	26.00/ea.

This mirror has no "Pontiac" script but has two studs 4 7/8" apart. Your sunvisor must be equipped with the two nylon inserts to accept this mirror.

COAT HOOKS



	PA715	PA716	PA716A	
PA715	1955-66	Coat Hook - Chrome - All exc. CVT (RE).....	\$11.00/pr.	
PA715J	1963-66	Coat Hook - Chrome - All CVT (RE).....	12.00/ea.	
PA716	1967-77	Coat Hook - Black Plastic - All exc. CVT (GM).....	12.00/pr.	
PA716A	1967-77	Correct Style Coat Hook - Black Plastic - All exc. CVT (RE).....	12.00/pr.	
PA716J	1976-77	Coat Hook Chrome - GP (GM).....	Disc.	

WINDLACE & EDGING



		PA546AB	
PA546AB	1955-57	Windshield Inner Lower Molding Center Clip (RE).....	4.50/ea.
PA547	1969-72	Front Windshield Upper Inner Lace, Black - GP (RE)	39.00/ea.

PA547 lace runs along the top of the windshield on the inside. Color available is black only—paint to match. Quality: Very good.

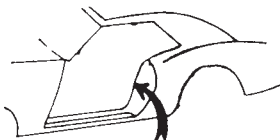

	PA800	PA802K	PA802M
PA800	1955-72	Windlace (5 ft. length) (RE).....	15.00/ea.

This is the windlace used on door posts and door lock pillars. It is a similar replacement for the leatherette style vinyl covered windlace used on convertibles and hardtops. Colors available: parchment and black.

PA802K	Early '69	Door Jamb Edging - GP (RE).....	22.00/pr.
---------------	-----------	---------------------------------	-----------

This is an exact reproduction of the early '69 style edging (cardboard with attached lace).

Note: PA802K is available in black only - paint to match.

PA802M	Late 1969-72	Door Jamb Edging - GP (RE).....	27.00/pr.
---------------	--------------	---------------------------------	-----------

Note: PA802M is available in black or white only - paint to match.

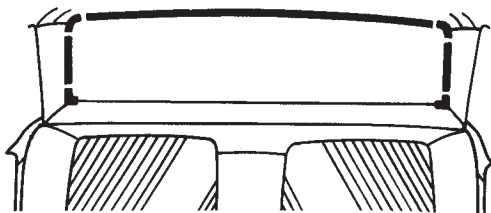

PA548B	1964	Rear Window Inner Lace Kit Sedan, 3pc.w/o Escutcheon (RE)	65.00/kit
PA548D	1965-66	Rear Window Inner Lace Kit Sedan, 3pc.w/Escutcheon (RE).....	95.00/kit

PA548B & PA548D are the three-piece kits that surround the rear window on the inside. The lace itself is molded around the corners as original.

Color available is black—paint to match.



PA548K

PA548K	1969-72	Rear Window Lace, Black-GP (RE).....	\$62.00/ea.
---------------	---------	--------------------------------------	-------------

This does not include lower corner pieces. Available in black only. Paint to match

Quality: Very good.

INTERIOR GARNISH MOLDING SCREW SETS



PA549GA

PA549GA	1955-57	Interior Garnish Molding Screw Set - 2 Dr. HT (RE)	6.50/set
PA549GB	1955-57	Interior Garnish Molding Screw Set - CVT (RE).....	6.50/set
PA549GC	1955-57	Interior Garnish Molding Screw Set - Safari (RE)	9.00/set
PA549GD	1955-57	Interior Garnish Molding Screw Set - SW (RE)	11.00/set
PA549GF	1955	Interior Garnish Molding Screw Set - 2 Dr Sedan (RE).....	6.50/set
PA549GG	1955	Interior Garnish Molding Screw Set - 4 Dr Sedan (RE).....	6.50/set
PA549GH	1956-57	Interior Garnish Molding Screw Set - 2 Dr Sedan (RE).....	6.50/set
PA549GJ	1956-57	Interior Garnish Molding Screw Set - 4 Dr Sedan (RE).....	6.50/set
PA549GK	1956-57	Interior Garnish Molding Screw Set - 4 Dr HT (RE)	6.50/set

Note: These sets contain enough chrome screws to attach all your interior Garnish Moldings.

PA549HS	1955-57	Windshield Pillar Molding Screws, Stainless Steel -All Exc. CVT (RE)	3.50/set
----------------	---------	--	----------

INTERIOR LAMP REFLECTORS & BEZELS



PA620

PA620	1955-58	Dome Lamp Reflector (RE)	32.00/ea.
--------------	---------	--------------------------------	-----------

This is the dome lamp located in the center of the headliner.



PA621

PA621	1955-57	Rear Quarter Lamp Reflector w/ Lens -2 Dr. HT, 4 Dr. HT, and Safari (RE)	35.00/ea.
PA621	1959-69	Rear Quarter Lamp Reflector w/ Lens -SW (RE)	35.00/ea.

This is the small round reflector found on both sides at the rear of the headliner. Comes complete with lens (PA631).



PA623

PA623	1962-64	Convertible Rear Armrest Courtesy Light Bezel (RE).....	27.00/ea.
--------------	---------	---	-----------



- | | | | | |
|---------------|--|-------------|-------|--|
| | PA625A | | PA628 | |
| PA625 | 1969-77 Dome Lamp Reflector (GM) | Disc. | | |
| PA625A | 1969-77 Dome Lamp Reflector (RE) | \$13.00/ea. | | |
| PA627 | 1959-62 Dome Lamp Bezel (RE) | Inquire | | |
| PA628 | 1963-64 Dome Lamp Bezel - exc. GP (RE) | 13.00/ea. | | |

INTERIOR LAMP LENSES



- | | | | | |
|---------------|--|-----------|--------|--|
| | PA630 | | PA630D | |
| PA630 | 1955-58 Dome Lens (Fits PA620 above) (RE)..... | 12.00/ea. | | |
| PA630D | 1958-64 Side Roofrail Dome Lens
(2 required) (RE) | 17.00/ea. | | |



- | | | | | |
|---------------|--|-----------|--|--|
| | PA630F | | | |
| PA630F | 1965-68 Side Roof Accessory Lens (APE) | 40.00/pr. | | |
- This rare accessory lens has been unavailable from GM for years. Since used pieces are usually cracked, these lenses will greatly enhance the interior of those cars with this desirable option.



- | | | | | |
|--------------|---|-----------|-------|--|
| | PA631 | | PA632 | |
| PA631 | 1955-57 Rear Quarter Lens - 2 Dr. and 4 Dr.
HT and Safari (Fits PA621) (RE)..... | 6.00/ea. | | |
| PA631 | 1959-69 Rear Quarter Courtesy Lamp Lens
- SW (Fits PA621) (RE)..... | 6.00/ea. | | |
| PA632 | 1958-61 Dome Lens Convertible
(3 1/2" x 1 9/16") (RE) | 10.00/ea. | | |



- | | | | | |
|----------------|--|-----------|-------|--|
| | PA635 | | PA636 | |
| PA635 | 1959-64 Dome Lens (Exc. Side Rail Lamps)
- Exc. '63-'64 GP (GM) | 10.00/ea. | | |
| PA636 | 1960-64 Dome Lens w/ Optional Reading
Lamp (APE) | 13.00/ea. | | |
| PA636AA | 1963-64 Dome Lens (exc. Side Rail
Lamps) - GP (RE) | 5.50/ea. | | |

This lens makes a good replacement; however, it is made from plastic instead of the original glass.



- | | | | | |
|---------------|--------------------------------|------------|--|--|
| | PA636A | | | |
| PA636A | Courtesy Light Lens (RE) | \$8.00/ea. | | |
- Note: This 1.5" diameter lens mounts on an aluminum bracket under the dash on cars equipped with the courtesy lamp accessory group. Originals are usually faded or cracked.



- | | | | | |
|--------------|---|-----------|-------|--|
| | PA637 | | PA638 | |
| PA637 | 1962-70 Rear Quarter Armrest Courtesy
Lamp Lens - CVT (RE) | 11.00/pr. | | |
| PA638 | 1971-75 Rear Quarter Armrest Courtesy
Lamp Lens - CVT (RE) | 12.00/pr. | | |



- | | | | | |
|--------------|------------------------------------|--|--|--|
| | PA639 | | | |
| PA639 | 1969-77 Dome Lens - All (RE) | | | |



- | | | | | |
|---------------|--|----------|--|--|
| | PA640 | | | |
| | | 5.50/ea. | | |
| PA639S | 1965-77 Round Dome Lens-Used with Optional
Reading Lamp - All (2 required) (GM) | Disc. | | |
| PA640 | 1969-77 Dome Lens w/Optional Reading | | | |



- | | | | | |
|----------------|---|----------|---------|--|
| | PA644J | | PA644JB | |
| PA644J | Dome Lamp Bulb Terminals (GM) | 3.50/pr. | | |
| PA644JB | 1969-77 Dome Lamp Mounting Kit (GM) | Inquire | | |



- | | | | | |
|----------------|---------------------------|----------|--|--|
| | PA644JK | | | |
| PA644JK | Dome Lamp Bulb (GM) | 2.00/ea. | | |
- Note 1: Replaces GE#211, 211-1, and 211-2.
Note 2: Please see the Electrical Section for other bulbs.

This kit contains 2 nuts and 2 studs.

INSIDE MIRRORS & COMPONENTS



PA380

PA380 1955-57 Inside Rearview Mirror, Non-Tilt (RE) ... \$27.00/ea.

This is meant as a replacement for the non-tilt standard mirror.

PA381 1955-57 Inside Rearview Mirror, Non-Glare, Tilt (RE) Disc.



PA382

PA382 1957-64 Inside Rearview Mirror - Tilt (RE) 59.00/ea.

Note: 1964 was a transition year for the tilt knob. This mirror has the black tab with day/night printed on it.



PA383

PA383 Late 1961-66 Inside Rearview Mirror Non-Tilt (RE) 21.00/ea.

PA384 1964-66 Inside Rearview Mirror - Tilt (RE) 69.00/ea.

This mirror is chrome, unlike the painted original.

Quality: Considered very good.



PA385A

PA385A 1967-68 Inside Tilt Mirror - 10" (RE) 49.00/ea.

Finally an exact reproduction of the original stainless steel tilt mirror.

Note 1: 1967 models had two knob designs. Both the triangular knob and this lever style were used on these cars.

Note 2: Due to current anti-glare legislation this original style mirror is not sold for street use but for shows, exhibitions, etc.

PA386 1969-70 Inside Tilt Mirror, 12" - FS (RE) 49.00/ea.

PA386A 1969-72 Inside Tilt Mirror, 12" - GP (RE) 49.00/ea.

This 12" stainless steel mirror exhibits the same excellent quality as the '67-'68 mirror described above.

Note 1: Most 1969 models had mirrors that were color-coded to the interior. The gray plastic surround on this reproduction easily accepts vinyl spray for that finishing touch.

Note 2: Due to current anti-glare legislation this original style mirror is not sold for street use but for shows, exhibitions, etc.

PA388 1971-77 Inside Tilt Mirror - FS (GM) Disc.

PA388 1973-77 Inside Tilt Mirror - GP (GM) Disc.

PA388 has a black back.



PA391

PA390 1955-57 Chrome Mirror Support - CVT (RE) \$109.00/ea.

PA391 1955-57 Chrome Mirror Support- HT & Sedan (RE) 29.00/ea.

Comments: Die-cast and excellent.

PA391H 1959-60 Chrome Mirror Support- CVT (RE) 69.00/ea.

PA391L 1961-62 Chrome Mirror Support- Catalina 2 & 4 Dr. Sedan and SW (RE) 29.00/ea.

Note: PA391L is for Catalina only. Quality is excellent.

PA391N 1961-62 Chrome Mirror Support- CVT (RE) 99.00/ea.

PA391R 1963-64 Chrome Mirror Support- CVT (RE) 99.00/ea.

PA391N and PA391R exhibit some flaws in the castings and chrome plating.

PA391S 1965-66 Inside Mirror Support- CVT 69.00/ea.

PA391T 1965-66 Inside Mirror Support- 2 & 4 Dr. HT 49.00/ea.



PA392J

PA392J 1968 Chrome Mirror Support - FS HT (RE) 29.00/ea.

PA392K 1969-72 Chrome Mirror Support - GP (RE) 29.00/ea.



PA393

PA393 1971-76 Inside Rearview Mirror Support - FS (GM) 12.00/ea.

PA393 1973-77 Inside Rearview Mirror Support - GP (GM) 12.00/ea.

PA393AJ 1958-69 Inside Mirror Mounting Screw - All (AP) 3.00/ea.

PA393AJ 1970-72 Inside Mirror Mounting Screw - GP (RE) 3.00/ea.

This 10/32 x 9/16" screw mounts the mirror to the bracket.

PA393AM 1971-76 Inside Rearview Mirror Adhesive Kit - FS (AP) 4.00/kit

PA393AM 1973-77 Inside Rearview Mirror Adhesive Kit - GP (AP) 4.00/kit



PA393AJ



PA393J

PA393J 1969-70 Inside Rearview Mirror Bracket Boot - GP (RE) 24.00/ea.

PA393J fits over the mirror bracket and holds the inside grommets of the sunvisors. Black - Paint to match.

FRONT END TRIM

FRONT END TRIM

FRONT EMBLEMS



PB105

- PB105** 1951, 53 Grille Lucite Emblem (Silver/Red) (APE) \$85.00/ea.
PB106 1952 Grille Lucite Emblem (Gold/Red) (APE) 85.00/ea.

Note: These emblems are also used on the wire wheel centers.



PB116

- PB115** 1962 Front Emblem w/Nuts (APE)..... 32.00/ea.
PB116 1963 Front Emblem w/Nuts- exc. GP (APE)... 32.00/ea.

PB115 and PB116 are die-cast to all original specifications. PB115 and PB116 have the original white and gold surfaces.

- PB117** 1963 Front Emblem w/Nuts - GP (RE) 37.00/ea.

Note: Low-pressure casting with correct satin brushed surfaces.



PB118

- PB118** 1964 "Pontiac" Grille Emblem -All Exc. Bonneville & GP (RE) 28.00/ea.

Note: This is a low-pressure casting.



PB120

- PB120** 1965 Front Emblem w/Nuts (RE) 39.00/ea.

PB120 has the satin-brushed surface.



PB121X

- PB121X** 1967 "Bonneville" Header Emblem (RE)..... 29.00/ea.



PB122

- PB122** 1967 Front Emblem - GP (RE) \$32.00/ea.

Using 2nd design specifications, this arrowhead was cast in a low pressure mold with correct chrome and satin brushed surfaces.



PB122A

- PB122A** 1967 Front Emblem - GP (APE)..... 28.00/ea.

Using third design specifications, this arrowhead has a steel core with a molded rubber exterior. May fit some 68 Models.

- PB122D** 1967 Front Arrowhead Emblem - exc. GP (RE) 32.00/ea.

- PB123J** 1969 Front Arrowhead Emblem - FS (RE)..... 31.00/ea.

- PB123K** 1970 Front Arrowhead Emblem - FS (RE)..... 31.00/ea.



- PB122F** 1967 "2+2" Header Emblem (RE) 26.00/ea.



PB126

- PB125Y** 1964 "GP" Grille Emblem (RE) 27.00/ea.

- PB126** 1966 "GP" Grille Emblem (RE) 27.00/ea.

- PB126B** 1967 "GP" Headlight Door Emblem (RE) 27.00/ea.

- PB126D** 1968 "GP" Grille Emblem (RE) 27.00/ea.

PB122F through PB126D are low-pressure castings. Overall quality is good.



PB127J

- PB127J** 1969 "428" Grille Emblem (RE) 26.00/ea.



TALK ABOUT FAST SERVICE!

AT AMES PERFORMANCE, WE HAVE ALWAYS MADE QUICK DELIVERY A HIGH PRIORITY. OUR VAST INVENTORY & EFFICIENT ORDER PROCESSING HAS KEPT THIS TRADITION ALIVE FOR OVER 30 YEARS.

IF YOU WANT YOUR PARTS FAST, WE'RE ONLY A PHONE CALL AWAY

PONTIAC

PB127L 1969 "Pontiac" Grille Emblem
- All exc. Bonneville & GP (RE) \$29.00/ea.



PB130 1971-72 "Grand Prix" Front Panel Script (RE) 26.00/ea.
PB127J-PB130 are not die-cast. They are low-pressure castings.
Overall quality is good.

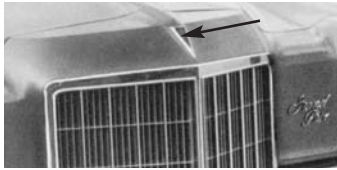

PB131 1971-72 Header Panel Emblem - GP (APE) 42.00/ea.



PB138J 1977 "Grand Prix" Header Nameplate (RE)... 24.00/ea.



PB138S "455" Grille Emblem (AP)..... 26.00/ea.
Note: This low-pressure casting is an afterproduct emblem that may be used for custom engine upgrade applications.

HEADLIGHT DOORS & BEZELS



PB139AD 1955 Headlight Eyebrow Molding (RE) Disc.



PB139AF 1956 Headlight Eyebrow Molding (RE) Disc.



PB139BM
PB139BK 1967 Headlight Bezel, LH Upper (NOS) Disc.
PB139BM 1967 Headlight Bezel, RH Upper (NOS)..... Disc.
PB139BP 1967 Headlight Bezel, LH Lower (NOS) Disc.
PB139BR 1967 Headlight Bezel, RH Lower (NOS)..... Disc.

These bezels fit; Catalina, Bonneville, Ventura, 2+2 & Executive.



PB139F 1969-70 Headlight Bezel Set - GP, 4 Pcs. (RE)..... \$209.00/set
PB139F are low-pressure castings.

HEADLIGHT DOOR GASKETS

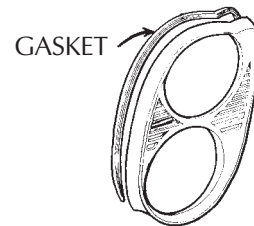

PB140 1955-57 Headlight Bucket Seals (RE) 5.00/pr.
PB140J 1955-57 Headlight Outer Rim to Sealed Beam Retaining Ring Seal (RE) 16.00/pr.
PB141 1958 Headlight Door Gasket (APE)..... 6.50/pr.
PB141J 1958 Headlight Outer Rim to Sealed Beam Retaining Ring Seal (RE) 26.00/set
PB145 1963 Headlight Door Gasket (APE)..... 6.50/pr.
PB146 1964 Headlight Door Gasket (APE)..... 6.50/pr.
PB147 1965 Headlight Door Gasket (APE)..... 6.50/pr.

These fender to headlight door gaskets were reproduced to exact GM specifications. These rubber strips replace your old hard or cracked originals.

HEADLIGHT DOOR COMPONENTS



PB150 1966 Headlight Door Nut (Long Plastic) (AP) 1.00/ea.
PB150B 1967 Headlight Door Nut (Square Plastic) (AP) 1.00/ea.
PB150J 1966-67 Headlight Door Screw (AP)..... 1.00/ea.

Note: These screws are difficult to locate since they have a #8-18 thread size and a #6 head.

Replacements are approximately 3/8" longer than original.

HEADLIGHTS, RINGS & SCREWS

PB188	1955-57 Halogen Round Headlight, 2 Headlamp System (AP)	\$15.00/ea.
PB188B	1958-70 Halogen Round Low Beam Headlight, 4 Headlight System -All (AP)	8.00/ea.
PB188D	1958-70 Halogen Round High Beam Headlight, 4 Headlight System- All (AP)	8.00/ea.
PB188B	1971-75 Halogen Round Low Beam Headlight, 4 Headlight System- FS Exc. 75 Bonneville & Grandville (AP)	8.00/ea.
PB188D	1971-75 Halogen Round High Beam Headlight, 4 Headlight System- FS Exc. 75 Bonneville & Grandville (AP)	8.00/ea.
PB188	1971-75 Halogen Round Headlight, 2 Headlight System - GP (AP).....	15.00/ea.
PB188F	1975-77 Halogen Square Low Beam Headlight, 4 Headlight System- Exc. 75 Cat & GP (AP)	7.00/ea.
PB188G	1975-77 Halogen Square Low Beam Headlight, 4 Headlight System- Exc. 75 Cat & GP (AP)	7.00/ea.

Note: PB188-PB188G are not correct but are inexpensive and brighter replacements for T-3 bulbs.



PB190D

PB190	1956-57 "T-3" Headlight Set (RE)	99.00/pr.
PB190B	1958-59 "T-3" Headlight Set (RE)	129.00/set of 4
PB190D	1960-67 "T-3" Headlight Set (RE)	129.00/set of 4
PB191	1968-70 "T-3" Headlight Set (RE)	129.00/set of 4

These new reproductions are the final touch for your detailed restoration. Bulbs are absolutely correct with "Guide" lettering and T-3 triangle.



PB192D

PB192RA

PB192	1955 Headlight Retainer Ring (2 Required) (GM)	42.00/ea.
PB192B	1956-57 Headlight Retainer Ring (2 Required) (RE)	16.00/ea.
PB192D	1958-67 Headlight Retainer Ring (4 Required) (GM)	48.00/ea.
PB192F	1958-67 Headlight Retainer Ring 4 Piece Set (RE)	20.00/set
PB192F is an inexpensive alternative to PB192D. Quality is very good.		
PB192	1971-72 Headlight Retainer Ring - GP (2 Required) (GM)	42.00/ea.
PB192J	1973-75 Headlight Retainer Ring - GP (2 Required) (GM)	79.00/ea.
PB192M	1976-77 Headlight Retainer Ring - GP (4 Required) (GM)	49.00/ea.
PB192RA	1955-62 Headlight Retainer Ring Screw - All (GM)	2.00/ea.
PB192RC	1963-77 Headlight Retainer Ring Screw -All (RE)50/ea.

HIDEAWAY HEADLIGHT COMPONENTS



PB155

PB155	1968 Headlamp Actuator Seals - GP & Bonneville (RE)	\$16.00/pr.
--------------	---	-------------

Note: This product seals the vacuum actuator and the rod; it is usually the cause of those common vacuum leaks in cars with hideaway headlights.



PB155A

PB155A	1968 Hideaway Headlamp Actuator w/Cover - GP & Bonneville (APE)	69.00/ea.
---------------	---	-----------

This reproduction is the complete actuator ready to bolt in. It includes the cover, case, rod, seals, and diaphragm. These actuators should finally cure those inoperative hideaway headlight doors.



PB155AA

PB155AA	1968 Actuator Covers, Pair - GP & Bonneville (APE)	16.00/pr.
----------------	--	-----------

These covers are usually missing on most cars.



PB155AK

PB155AK	1968 Headlamp Actuator Dust Boots, . (APE)	17.00/pr.
----------------	--	-----------

Note: These boots are designed to keep the inside of the actuators free from dirt and dust.

Hideaway headlight components continue on next page.



Hideaway headlight components continued.



- | | | | | |
|----------------|---------|---|-------------|--|
| | PB155B | PB155BJ | PB155BL | |
| PB155B | 1968 | Hideaway Headlamp Vacuum Canister - GP & Bonneville (RE) | \$51.00/ea. | |
| | | This reproduction is the vacuum can mounted on the inner fender. Many originals are missing or damaged. | | |
| PB155BJ | 1967-68 | Hideaway Headlamp Vacuum Line Check Valve - GP & Bonneville (GM)... | 11.00/ea. | |
| PB155BL | 1967-68 | Hideaway Headlamp Vacuum Line Check Valve - GP & Bonneville (NOS) . | 12.00/ea. | |



- | | | | |
|----------------|---------|--|-----------|
| | PB155BR | PB155BT | |
| PB155BR | 1968 | Hideaway Headlight Vacuum Can Supply Hose Kit - GP and Bonneville (RE) | 43.00/kit |
| | | This is the correct blue striped supply line from the carburetor to the canister. The kit includes a tee fitting, plastic union and a PB155BJ valve. | |
| PB155BT | 1968 | Hideaway Headlight Firewall Grommet (RE) | 10.00/ea. |



- | | | |
|---------------|--------|--|
| | PB155C | |
| PB155C | 1968 | Hideaway Headlight Bushing Kit, 14 Pieces - GP and Bonneville (RE) |
| | | 19.00/set |
| | | This kit is a must for '68 hideaway owners. Many times drooping or malfunctioning hideaway doors can be rejuvenated with this kit alone. Don't spend needless money and time on actuators etc. until you've first installed these bushings. Discard unused bushings. |



Note: Hideaway headlight switches for '68 GPs & Bonneville are available in the Electrical Section. Part number PM229T.



- | | | |
|---------------|--------|---|
| | PB155D | |
| PB155D | 1968 | Hideaway Actuator Bushing Retainer Clip - GP & Bonneville (RP) |
| | | 1.00/ea. |
| | | Requires 4 per car. |

HEADLIGHT ADJUSTER & SPRINGS



- | | | | |
|---------------|---------|---|------------|
| | PB160 | | |
| PB159J | 1955-61 | Headlight Adjusting Screw (AP) | \$2.00/ea. |
| PB159M | 1961 | Headlight Adjusting Nut and Screw Kit (4 per kit) (RE)..... | Inquire |
| PB160 | 1962-68 | Headlight Adjusting Nut and Screw (AP) | 2.00/ea. |
| PB160 | 1969-70 | Headlight Adjusting Nut and Screw - GP (AP)..... | 2.00/ea. |
| PB160D | 1969 | Headlight Adjusting Nut and Screw - FS (AP)..... | 2.00/ea. |
| PB160A | 1970 | Headlight Adjuster and Spring Kit - FS (RE) | Inquire |
| PB160B | 1971 | Headlight Adjusting Nut and Screw Kit - GP (RE)..... | Inquire |
| PB160C | 1972 | Headlight Adjuster and Spring Kit - GP (4 Adjusters and 4 Springs) (RE) | Inquire |



- | | | | |
|---------------|---------|--|----------|
| | PB160D | | |
| PB160D | 1973-75 | Headlight Adjusting Nut and Screw - GP (AP)..... | 2.00/ea. |
| PB160E | 1971 | Headlight Adjuster and Spring Kit - FS (8 Adjusters and 4 Springs) (RE)..... | Inquire |
| PB160F | 1972,74 | Headlight Adjuster and Spring Kit - FS (8 Adjusters and 4 Springs) (RE)..... | Inquire |
| PB160H | 1973 | Headlight Adjuster and Spring Kit - FS (8 Adjusters and 4 Springs) (RE)..... | Inquire |
| PB160G | 1976-77 | Headlight Adjusting Nut and Screw - GP (AP)..... | Inquire |
| PB160M | 1955-58 | Headlight Adjusting Spring (AP)..... | Inquire |
| PB160R | 1965-66 | Headlight Adjusting Spring (AP)..... | Inquire |



- | | | | |
|---------------|---------|--|----------|
| | PB160T | | |
| PB160T | 1968-69 | Headlight Adjusting Spring - FS (AP)..... | 2.00/ea. |
| PB160V | 1969-70 | GP & 1970 FS Headlight Adjusting Spring (AP)..... | 2.00/ea. |
| PB160W | 1971-73 | GP & 1971-72 FS Headlight Adjusting Spring (AP)..... | 2.50/ea. |
| PB160X | 1973 | Headlight Adjusting Spring - FS (AP)..... | 2.00/ea. |
| PB160Y | 1974-77 | Headlight Adjusting Spring - All (GM) .. | 2.50/ea. |

GRILLE MOUNTING GROMMETS



- | | | | |
|---------------|-------|--|-----------|
| | PB270 | | |
| PB270 | 1968 | Grille Mounting Grommet Bonneville & GP | 3.00/ea. |
| PB270A | 1968 | Grille Mounting Grommet (Set of 4) Bonneville & GP | 10.00/set |

FRONT END TRIM

PARKING LAMP COMPONENTS

PB161N 1955-77 Parking Lamp Bulb (NOS) Inquire
 PB161N is the correct amber painted bulb used in various applications between 1955 & 1977.



PB161TL

PB161TL 1955 Parking Lamp Lens, LH (RE) \$43.00/ea.
PB161TR 1955 Parking Lamp Lens, RH (RE) 43.00/ea.
PB161TS 1955 Parking Lamp Lens Gaskets (RE) 6.50/pr.



PB162

PB162 1956 Parking Lamp Lenses (RE) Disc.
PB162A 1956 Parking Lamp Lens Gaskets (RE) 6.50/pr.
PB163 1957 Parking Lamp Lenses (RE) 32.00/pr.
PB163A 1957 Parking Lamp Lens Gaskets (RE) 6.50/pr.



PB163

Comments: Excellent.



PB164D

PB164D 1958 Parking Lamp Lenses (RE) 49.00/pr.



PB164J

PB164J 1958 Parking Lamp Lens Gaskets (RE) 13.00/pr.

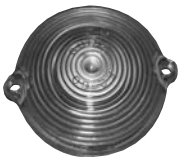

PB166

PB166 1960 Parking Lamp Lens LH or RH (RE) 14.00/ea.



PB168

PB168 1963 Parking Lamp Lenses, Clear - GP (APE) 65.00/pr.

Finally - These highly sought-after lenses have been reproduced. Quality is excellent.



PB169

PB169 1963-64 Parking Lamp Lenses, Clear
 -Exc. GP (APE) 32.00/pr.
PB170 1964 Parking Lamp Lenses, Amber
 -Exc. GP (APE) 32.00/pr.
PB171 1965 Parking Lamp Lenses, Clear
 -Exc. GP (APE) 32.00/pr.
PB172 1963-65 Parking Lamp Lenses Gaskets
 -Exc. GP (APE) 7.00/pr.

Because of the exceptional quality and customer response to our previous lenses we enlisted the same supplier to make these 1963-65 lenses.



PB175

PB175 1965 Parking Lamp Lenses - GP (APE) \$35.00/pr.
 Each lens is complete with stamped metal and cast shield assembly. Quality is excellent.



PB176

PB176 1965 Parking Lamp Gaskets - GP (APE) 7.00/pr.
 Unlike stamped gaskets, PB176 gaskets are made of molded rubber, same as originals.



PB177

PB177 1965 Parking Lamp Bezels - GP (APE) 30.00/pr.
 These chrome die-cast bezels were introduced in conjunction with PB175 and PB176. Again, quality is excellent.



PB178

PB178 1965 Parking Lamp Set - GP (APE) 69.00/set
 Save money by purchasing all of the above parking lamp components. Each set contains two lenses, two lens gaskets, two lens bezels, and hardware.



PB180P

PB180P 1968 Parking Lamp Lens, LH- FS (APE) 51.00/ea.
PB180R 1968 Parking Lamp Lens, RH- FS (APE) 51.00/ea.
 Although not absolutely correct, these lenses will fit. Design and appearance differ from originals.

Parking lamp components continue on next page

FRONT END TRIM

Parking lamp components continued



- PB180V
- PB180T** 1968 Parking Lamp Housing, LH
-All FS (RP) \$65.00/ea.
- PB180V** 1968 Parking Lamp Housing, RH
-All FS (RP) 65.00/ea.

Note: Parking lamp housings come complete with the very unique bulb sockets and lens gasket. These are the later 1968 design with only one socket and no marker light. Light bulb is not included. These are replacements. They are not exact but fit and function fine.

Quality: Very good.

- PB180W** 1968 Parking Lamp Assembly to Valance
Hardware Kit, 12 pcs. per kit (RE) 5.00/kit
- 1 kit per car.



- PB180S
- PB180S** 1968 Parking Lamp Lens Gaskets, Pair (RE) ... 5.00/pr.



PB182GR



PB182J

- PB182GL** 1970-72 Parking Lamp Lens - GP, LH (RE) 89.00/ea.
- PB182GR** 1970-72 Parking Lamp Lens - GP, RH (RE) 89.00/ea.
- PB182GL & PB182GR will work for 1969 GP; however these have an amber side reflector.

- PB182J** 1969-72 Parking Lamp Lens and Bezel
Screw - GP (AP) 1.00/ea.
- PB182J are the hard to find #8 - 18 x 4" long screws.

SIDE MARKER LENS & CLIP



PB250



PB251

- PB250** 1969 Side Marker Lenses - Executive
SW (APE) 22.00/pr.

This is an exact plastic reproduction of the two-piece lenses mounted on the sides of the front valance panel.

- PB251** 1969 Side Marker Lens Clip - Executive
SW (RE) 26.00/pr.

Comments: These are the clips used to secure side marker lens to the valance.

FRONT END BOLT KITS



- PB185A** 1955-57 Front End Bolt Kit (AP) Inquire
- PB185C** 1958 Front End Bolt Kit (AP) Inquire
- PB185D** 1959-60 Front End Bolt Kit (AP) Inquire
- PB185E** 1961-62 Front End Bolt Kit (AP) Inquire
- PB185F** 1963-64 Front End Bolt Kit (AP) \$36.00/kit
- PB185G** 1965-66 Front End Bolt Kit (AP) 36.00/kit
- PB185H** 1967-68 Front End Bolt Kit (AP) Inquire
- PB185J** 1969-70 Front End Bolt Kit - FS (AP) Inquire
- PB185K** 1969-72 Front End Bolt Kit - GP (AP) 36.00/kit
- PB185L** 1971-75 Front End Bolt Kit - FS (AP) Inquire
- PB185M** 1973-77 Front End Bolt Kit - GP (AP) Inquire

Note: These kits contain enough bolts and shims to assist in assembly of the front end sheet metal.

BUMPER BOLTS



PB221

- PB220** 1955-63 Round Head Stainless Steel Cap
Bumper Bolt w/ Nut (RE) 1.50/ea.
- PB221** 1964-72 Pan Head Stainless Steel Cap
Bumper Bolt w/ Nut (RE) 1.50/ea.

LICENSE PLATE MOUNTING



PB225

- PB225** 1955-59 Front License Mounting Kit (RE) 3.50/ea.
- PB225** 1963-75 Front License Mounting Kit (RE) 3.50/ea.
- (Includes 2 rubber bumpers, 2 nylon nuts, and 2 screws.)
- PB230** 1968-72 Front License Plate Bumper
(Mounting Bracket to Valance
Panel) (RE) 1.00/ea.

RADIATOR SUPPORT BAFFLE



PB301

- PB301** 1969 Radiator Support Lower Air Baffle
w/mounting hardware - All FS w/AC &
All GP (RE) 37.50/ea.



PB305

- PB305** 1969 Radiator Support Air Baffle
Extensions (RE) 16.00/pr.

Comments: PB301 and PB305 are exact reproductions of the factory-installed air baffles and extensions. Constructed of hair-cell pattern plastic, they divert additional air through the radiator for better engine cooling.

FRONT END TRIM

FRONT FENDER TRIM

FENDER EMBLEMS & ORNAMENTS



PC100

PC100 1955 Chrome Star Ornament (RE)..... \$15.00/ea.



PC105

PC105 1956 Front Fender "V8" Emblems (APE) 55.00/pr.
Note: These high-quality die-cast emblems have the white border around the outside edges. '56 emblems typically did not use this border.



PC110

PC110 1957 "Star Chief" Fender Script (APE) 70.00/pr.
This brand-new reproduction is die-cast in one-piece like originals.
Note: Beware of the two-piece low-pressure reproductions on the market.



PC114

PC112

PC112R 1957 Front Fender Louver, RH - Bonneville (RE) 26.00/ea.
PC112L 1957 Front Fender Louver, LH - Bonneville (RE) 26.00/ea.
PC112 1957 Front Fender Louver Set - Bonneville (14 Pieces) (RE) 339.00/set
PC114 1957 Fuel Injection Emblems, Set of 3 (RE).... Disc.

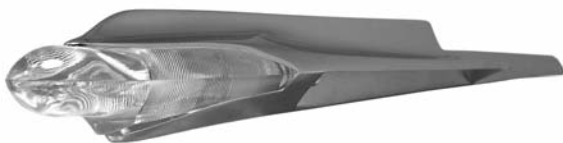

PC114K

PC114K 1957 Complete Illuminated Fender Ornaments (APE) 329.00/pr.

Note 1: These ornaments are correct for all '57 models from Chieftains through Bonneville.

Note 2: Each assembly consists of chrome ornament, lucite insert and wiring. Attaching studs are in the same position as the non-illuminated standard fender ornaments. As in original installations, one small hole must be drilled under the ornament for wiring.



PC114L

PC114L 1957 Illuminated Fender Ornament Inserts (APE)..... \$86.00/pr.

Many vehicles have nice ornaments but their inserts are badly cracked. These reproductions will greatly enhance your original assemblies.



PC115

PC115 1958 "Tripower" Fender Emblem (RE)..... 82.00/pr.



PC116

PC116 1958 "Fuel Injection" Fender Emblem (RE).... Disc.



PC116j

PC116j 1958 "Star Chief" Fender Emblem, Gold, LH or RH (RE) 34.00/ea.



PC117

PC117 1958 Front Fender Side Louver Set, 8pcs. (RE) Disc.
PC117L 1958 Front Fender Side Louver, LH (RE)..... Disc.
PC117R 1958 Front Fender Side Louver, RH (RE) Disc.



PC118

PC118 1958 "Bonneville" Fender Emblem, Gold Plated (RE)..... 34.00/ea.

Note: PC118 is a low-pressure casting which exhibits minor shrinkage. Mounting holes may have to be elongated to facilitate attaching.



PC120

PC120 1959 "Tripower" Fender Emblems (Gold) (RE)... 79.00/pr.



PC122

PC122 1960 Bonneville Fender Emblems (RE)..... 52.00/pr.

FRONT FENDER TRIM

BONNEVILLE

PC127

PC127 1961 "Bonneville" Fender Letters
(10 pieces) (RE) \$179.00/set

Requires two sets per car.



PC130

PC130 1962-64 "421" Fender Emblems (RE)..... 78.00/pr.



PC150

PC140 1963 "Grand Prix" Fender Letters (9 pcs.) (RE) 75.00/set

PC150 1964 "2+2" Fender Emblems (RE)..... 46.00/pr.

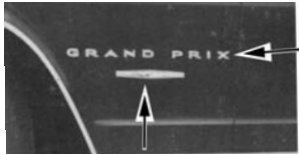

PC152J

PC152 1964 "Grand Prix" Fender Letters
(9 pieces) (RE) 75.00/set

PC152A 1964 "Grand Prix" Fender Letters
(18 pieces) (RE) 149.00/set



PC152J

PC152J 1964 Grand Prix Front Fender Emblem (RE) .. 39.00/ea.



PC158

PC158 1965 2+2 Louvers (RE)..... 14.00/ea.

Note: 10 louvers required per side.



PC158J

PC158J 1965 "Catalina" Fender Emblem (RE)..... 39.00/ea.



PC160

PC160 1965 "421" Fender Emblems (RE)..... 83.00/pr.

PC161 1965 "Grand Prix" Fender Letters (RE)..... 75.00/set



PC162

PC162 1965 Bonneville Fender Emblems (RE)..... 179.00/pr.

PC168 1966 "Bonneville" Door and Fender
Letters (10 pcs) (RE) 113.00/set

2 sets required per car.



PC169

PC169 1966 "Catalina" Fender Emblems (RE) \$52.00/pr.

PC170 1966 "421" Fender Emblems (Exc. 2+2) (RE) . 89.00/pr.

PC171 1966 "421" Fender Emblem - 2+2 (RE) Disc.

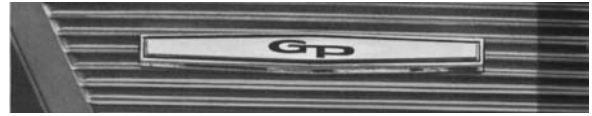

PC171J

PC171J 1966 Grand Prix Fender Emblem (RE)..... 39.00/ea.

PC171L 1966 "Grand Prix" Fender Letters (RE)..... 75.00/set



PC171R

PC171R 1967 Grand Prix Fender Emblem (RE)..... 39.00/ea.

This emblem mounts on the rocker panel molding with self-tapping screws (not included).



PC171Y

PC171Y 1967-68 "Catalina" Front Fender Letters
(8 Pieces) (RE) 83.00/set



PC172

PC172 1967 "428" Fender Emblems (RE)..... 91.00/pr.

PC176J 1968 "428" Fender Emblems (RE)..... 89.00/pr.



PC177

PC177 1968 "Bonneville" Fender Letters
(10-pcs) (RE)..... 105.00/set

PC177A 1968 "Bonneville" Fender Letters
(20-pcs) (RE)..... 209.00/set

PC178 1969 "428" Fender Emblems - All (RE)..... 49.00/pr.



PC180

PC180 1969-72 "Model SJ" Emblems - GP (RE) 59.00/pr.



PC181

PC181 1969 Model J Emblems - GP (RE) 56.00/pr.

PC200 1969 "Grand Prix" Fender Letters
(9 pcs.) (RE)..... 84.00/set

PC200A 1969 "Grand Prix" Fender Letters
(18 pcs.) (2 sets) (RE) 169.00/set

Comments: PC114 through PC200A are not die-cast. These pieces are low-pressure castings.

Overall quality is good.

FRONT FENDER TRIM

Catalina

PC205 1969-70 "Catalina" Front Fender Emblem (RE)... \$28.00/ea.

CATALINA

PC220 1971-74 "Catalina" Front Fender Emblem (RE)... 29.00/ea.



PC225 1973-77 "SJ" Front Fender Emblem - GP (RE)..... 26.00/ea.



PC228 1973-77 "Grand Prix" Fender Emblem (NOS)..... Inquire



PC240 "350" Rocker Panel Molding Emblems (AP) 51.00/pr.



PC241 "400" Rocker Panel Molding Emblems (AP) 51.00/pr.



PC242 "455" Rocker Panel Molding Emblems (AP) 51.00/pr.

Although not original on full-size Pontiacs, many owners have used these as afterproduct add ons.

WHEELWELL TRIM



PC300 1964-77 Wheelwell Molding Screw Set (RE) 5.50/set
Each set of wheelwell molding screws does one complete car (32 screws). Screws are the same as GM with the unique washer head design.

PC326L 1971-72 Front Wheelwell Molding w/Screws, LH - FS (NOS)..... Disc.

PC326R 1971-72 Front Wheelwell Molding w/Screws, RH - FS (NOS)..... 47.00/ea.

Add \$12.00 oversize fee to standard shipping for wheelwell moldings.



BODY SIDE MOLDING CLIPS



PC350 Plastic Body Side Molding Clip (RE) \$2.00/ea.

Overall dimensions: .330" x .820" Fits .220" x .500" hole.

PC350A Plastic Body Side Molding Clip (RE) 2.00/ea.

Overall dimensions: .435" x .960" Fits .300" x .550" hole.

PC350B Plastic Body Side Molding Clip (RE) 2.00/ea.

Overall dimensions: .600" x .960" Fits .300" x .550" hole.

PC350 - PC350B are used on many different cars. Refer to photo and dimensions for your application.

INNER FENDERWELLS & COMPONENTS



PC420 1955-57 Lower Front Fender Shims (RE) 6.00/set



PC424L

PC424L 1969-72 Front Inner Fender, LH - GP (RE)..... 155.00/ea.

PC424R 1969-72 Front Inner Fender, RH - GP (RE) 155.00/ea.

Quality and fit are very good.

Add \$99.00 oversize fee to standard shipping for inner fenders.



PC425C

PC425C Inner Fender Well Nut, Plastic (RE)..... 1.00/ea.

PC425E Inner Fender Well Nut, Steel (RE) 1.00/ea.

Note: These nuts secure the outer fender to the inner fender wells. Used on various years, refer to photos for designs.



PC425E

FRONT FENDER TRIM

HOOD COMPONENTS

HOOD EMBLEMS



- PD105** 1955 Hood Ornament Insert - Indian Head Amber (RE) \$85.00/ea.
PD106 1955 Hood Ornament Insert - Indian Head Clear (RE)..... 85.00/ea.

Note: PD105 & PD106 are the plastic inserts only.



- PD107** 1956 Accessory Hood Ornament Insert - Clear (RE)..... 55.00/ea.

Note: This is the clear plastic insert only.



- PD110** 1957 Hood Emblem Lucite Insert (APE)..... 53.00/ea.

This is our own reproduction of the '57 front plastic emblem. Most originals are either cracked or faded and should be replaced by one of these excellent reproductions.



- PD111B** 1958 "Bonneville" Hood Letters (RE) 165.00/set
PD113 1960 "Pontiac" Hood Letters (RE) 49.00/set



- PD115** 1961 Hood Arrowhead w/Nuts (APE) 32.00/ea.

- PD116** 1964 Hood Arrowhead w/Nuts (APE) \$32.00/ea.
 PD115 & PD116 are die-cast to all original specifications including satin-brushed surfaces.



- PD117Y** 1965 "GP" Hood Emblem (RE)..... 37.00/ea.



- PD118** 1965 "2+2" Hood Emblem w/Nuts (RE) 35.00/ea.
PD119 1966 "2+2" Hood Emblem w/Nuts (RE)..... 40.00/ea.
PD120 1966 Hood Arrowhead w/Nuts (RE)..... 32.00/ea.



- PD130** 1969-70 Hood Emblem - GP (APE)..... 19.50/ea.
PD131 1969-70 Hood Emblem Bezel - GP (APE)..... 19.50/ea.
PD132 1969-70 Hood Emblem and Bezel - GP (APE) 37.00/set



Note: Save money on both PD130 and PD131 by purchasing them as a set.

Comments: The 1969-70 Grand Prix hood emblem and bezel are both excellent reproductions. Some light filing may be required on PD130 to fit into bezel properly.

COWL SCREENS & GRILLES

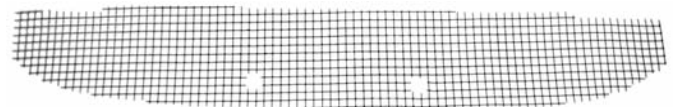

- PD149** 1969 Cowl Screen - GP (APE)..... 20.00/ea.
 PD149 is made from the correct size wire mesh.
PD149B 1969 Cowl Screen Bolt Kit, 4 pc. (RP) 6.00/kit

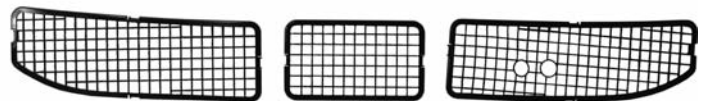

- PD150** 1970-72 Cowl Grille, 3 Pc. - GP (RE)..... 20.00/set

Note: These reproductions are made to replace your old broken or missing grilles. Cowl grilles are molded from a heat-resistant material to resist distortion. These grilles are used on cars with or without air conditioning. Although not correct, these can also be used on 1969 Grand Prix.

HOOD BUMPERS



PD200



PD200A

PD200 1955-63 Hood Bumper Cap - Front or Rear (RE). \$2.50/ea.

Note: PD200 is the rubber cap only.

PD200A 1955-63 Hood Bumper Stud (RE)..... 3.50/ea.

PD200B 1955-63 Hood Bumper Assembly (RE)..... 5.50/asm.

PD200B consists of PD200 and PD200A.

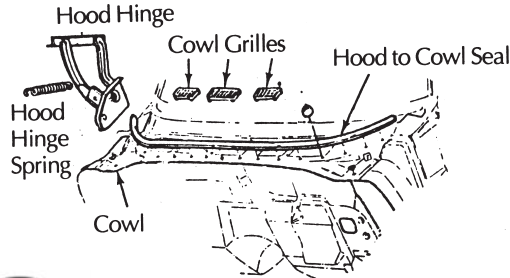

PD204



PD205



PD206

PD204 1966-77 Hood Bumper Cap - Front Adjustable (RE)..... 2.50/ea.

This is an exact reproduction of the cone-shaped cap used on the front adjustable bumper for these years. You must reuse the original stud and nut.

PD205 1964-65 Hood Bumper w/Stud - Front Adjustable (GM) 5.00/ea.

PD205AB 1964-65 Hood Front Bumper, Pair (RE) 6.00/pr.

PD205AB are exact reproductions and require the use of your original studs.

PD206 1966-77 Hood Bumper w/Stud - Front Adjustable (RE)..... 4.50/ea.

PD206 is an exact reproduction utilizing the rubber cap w/the stud.



PD207



PD216

PD207 1967-72 Hood Rear Bumper - All (GM) 4.00/ea.

PD207 1973-76 Hood Rear Bumper - FS (GM) 4.00/ea.

PD207 is a GM replacement that is now too tall. It must be cut for your specific application (actual height is 1 3/16").

PD207C 1967-72 Hood Rear Bumper - All (RE) 9.00/pr.

PD207C 1973-76 Hood Rear Bumper - FS (RE) 9.00/pr.

These reproductions are much closer to the original design (actual height is 7/8").

PD208 1973-77 Bumper Hood to Cowl Round - GP..... Inquire

PD212 1955-57 Hood to Fender Bumper - All (APE)..... 2.50/ea.

PD214 1958 Hood to Fender Bumper - All (RE) 3.50/ea.

PD215 1959-63 Hood to Fender Bumper - All (RE) 3.50/ea.

PD216 1964-68 Hood to Fender Bumper - All (RE) 2.00/ea.

PD218 1969 Hood to Fender Bumper - All (RE) 2.00/ea.

PD222 1970-72 Hood to Fender Bumper - All (RE) 1.50/ea.

PD222 1973-76 Hood to Fender Bumper - FS (RE)..... 1.50/ea.

PD224 1973-77 Hood to Fender Bumper - GP Inquire

PD250 1955-56 Cowl Panel Bumpers (RE) 5.50/set

HOOD TO COWL SEALS

PD260 1955-56 Hood to Cowl Seal, w/o Clips (RE) \$10.00/ea.

PD261 1957-58 Hood to Cowl Seal, w/o Clips (RE) 10.00/ea.

PD262 1959-60 Hood to Cowl Seal, w/o Clips (RE) 10.00/ea.

PD265 1961-62 Hood to Cowl Seal, w/o Clips (RE) 11.00/ea.

PD266 1963-64 Hood to Cowl Seal, w/o Clips (RE) 10.00/ea.

PD268 1965-66 Hood to Cowl Seal, w/o Clips (RE) 32.00/ea.

PD269 1967-68 Hood to Cowl Seal, w/ Clips (RE) 21.00/ea.

PD269G 1969-72 Hood to Cowl Seal w/ Clips GP (RE)..... 12.00/ea.

PD272 1971-76 Hood to Cowl Seal, w/ Clips FS (RE) 20.00/ea.

The hood to cowl seal is mounted along the upper portion of the firewall. This weatherstrip seals the rear portion of the engine compartment.



PD290



PD293J

PD290 1955-67 Hood to Cowl Seal Clip (GM) 1.50/ea.

PD291 1968-77 Hood to Cowl Seal Metal Clip (RE)..... 2.50/ea.

PD293J 1959-60 Cowl Side Drain Gutter - Sedan (RE) 92.00/pr.

PD293L 1961-62 Cowl Side Drain Gutter - All (RE) 85.00/pr.

HOOD TO WINDSHIELD FRAME PADS

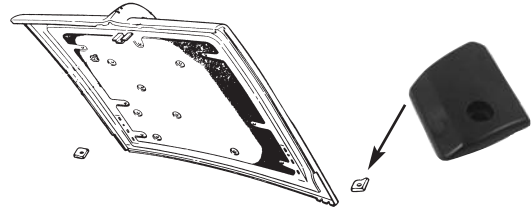

PD295

PD295 1969-72 Hood to Windshield Side Frame Pad - GP (RE) 18.00/pr.

Note: These items may be the most sought-after pieces needed in 1969-72 GP's. Every original seems to be cracked or destroyed.

Our reproductions are made of high impact plastic to keep your hood from gouging the cowl area when closing.

HOOD HINGES & COMPONENTS



PD332NL



PD330

PD330 1969-70 Hood Hinge Spring - FS (GM) 16.00/ea.

PD330B 1973-77 Hood Hinge Spring - GP (RE) 16.00/ea.

PD332L 1964 Hood Hinge, LH (APE) 75.00/ea.

PD332R 1964 Hood Hinge, RH (APE) 75.00/ea.

PD332NL 1969-70 Hood Hinge, LH -FS (APE)..... 75.00/ea.

PD332NR 1969-70 Hood Hinge, RH -FS (APE) 75.00/ea.



PD334C

PD334B 1963-66 Hood Hinge Nut and Bolt Kit (RP)..... 5.50/kit

PD334C 1967-77 Hood Hinge Bolt Kit (RP)..... 4.50/kit

HOOD COMPONENTS

HOOD TACHS & COMPONENTS

Reproduction hood tachometers are available several different ways to accommodate your specific needs. The First group offered has been time-tested for over 20 years and proven to be a good quality tach at a great price. The 2nd group of tachs exhibit a more original appearance, primarily on the underside, and work with all original components such as wiring and vent tubes. Both styles offer very good quality and use the latest electronic technology.

Note 1: Please test your new tach for fit and functionality before painting it.

Note 2: Before painting, lightly scuff the primer on these tachs. Under no circumstances should the primer be removed.

Note 3: These reproduction tachs will work with points or GM HEI ignition. For aftermarket ignition compatibility, see the N219WL adapter harness.

Note 4: It appears the 1968 Ram Air II was the only application that Pontiac had intended using a 5500 Red line Hood Tach on.

Note 5: 1968-Late 69 tachs have a steel blue face while 69 & later have a black face.

Comments: Very good. Externally all units are now made to exact factory two-piece specifications. Tach wiring harnesses for original hood tachs are available separately in the Electrical section, but are also included with each new reproduction tach. (Factory harnesses cannot be used with the \$215.00 tachs.)



PD341

PD341	1967	Hood Tach (RE).....	\$215.00/ea.
PD342	1968 to Early '69	Hood Tach - 5100 Redline - All (RE).....	215.00/ea.
PD342A	1968 to Early '69	Hood Tach - 5500 Redline - All (RE).....	215.00/ea.
PD343	Late 1969-72	Hood Tach - 5100 Redline - GP (RE)	215.00/ea.
PD343A	Late 1969-72	Hood Tach - 5500 Redline - GP (RE)	215.00/ea.



PD344C

PD342B	Late 1968 to Early '69	Hood Tach-5100 Redline - GP (RE)	239.00/ea.
PD342C	Late 1968 to Early '69	Hood Tach-5500 Redline - GP (RE)	239.00/ea.
PD344C	Late 1969-72	Hood Tach-5100 Redline - GP (RE)	239.00/ea.
PD344F	Late 1969-72	Hood Tach-5500 Redline - GP (RE)	239.00/ea.



PD341G

PD341G	1967	Hood Tach Gasket (RE).....	9.50/ea.
---------------	------	----------------------------	----------

This gasket is located between the hood and the tach.



PD344L

PD344L	1967-72	Hood Tach Vent Line Kit (RE)	33.00/kit
---------------	---------	------------------------------------	-----------

HOOD RELEASE COMPONENTS



PD349B

PD349B	1968-70	Hood Latch Assembly - All (RE).....	Inquire
PD349D	1971-72	Hood Latch Assembly - GP(RE).....	Inquire
PD349H	1968-72	Hood Latch Bolt, 3 pc. set (RE).....	\$1.50/set



PD349H



PD349K



PD349L

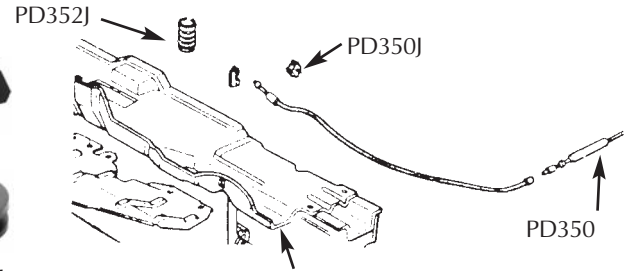

CORE SUPPORT

PD349K	1967-70	Hood Release Rod Retainer Clip (RP) ...	1.00/ea.
PD349L	1967-70	Hood Release Rod Grommet, All (RP)..	3.00/ea.
PD350	1971-76	Hood Release Handle w/Cable - FS (GM)	Disc.
PD350	1973-77	Hood Release Handle w/Cable - GP (GM)	Disc.
PD350J	1971-76	Hood Release Cable Retainer - FS (GM)	2.50/ea.
PD350J	1973-77	Hood Release Cable Retainer - GP (GM)	2.50/ea.
PD350L	1971-76	Hood Release Cable Grommet - FS (GM)	Disc.
PD350L	1973-77	Hood Release Cable Grommet - GP (GM)	Disc.
PD352A	1971-72	Hood Pop Springs - GP (RE).....	Disc.
PD352D	1971-73	Hood Pop Spring - All (RE)	Disc.
PD352D	1974-77	Hood Pop Spring - GP (RE)	Disc.
PD352J	1974-76	Hood Pop Spring - FS (GM)	Disc.

HOOD LAMP KITS



PD362

PD360	1963-68	Underhood Lamp Kit (RE).....	Disc.
PD360C	1969-70	Underhood Lamp Kit - GP (RE)	Disc.

These kits are a reproduction of the accessory package for underhood lighting.

PD362	Universal Underhood Lamp Kit - All (AP).....	35.00/ea.
--------------	--	-----------

This light attaches to the underside of the hood, not the firewall. It is activated by a mercury switch in the light assembly. Wiring included.

Please check the Trunk Components section for trunk lamp kits.

UNDERHOOD INSULATION

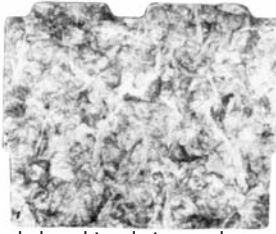

Our reproduction underhood insulation pads are die-cut from material very close to original.

Comments: Very good. The outline material and hole locations are excellent. The product does not have the material compressed in the small areas around the perimeter as did the original, but does have a backing for added strength.

Note: For many full-size Pontiacs, the insulation pad covers only a small portion of the hood. They are usually positioned over the engine itself.

Note: When installing these pads, install the fuzzy side toward the motor and the hard backing towards the hood.

PD400	1956	Underhood Insulation Pad - Yellow (RE)	\$28.00/ea.
PD400A	1956	Underhood Insulation Pad - Yellow w/Wire Retainer Kit (See #PD398) (RE)	44.00/ea.
PD400C	1956	Underhood Insulation Pad - Gray (RE)..	26.00/ea.
PD400D	1956	Underhood Insulation Pad - Gray w/Wire Retainer Kit (See #PD398) (RE)	44.00/ea.
PD401	1957	Underhood Insulation Pad - Yellow (RE)	28.00/ea.
PD401A	1957	Underhood Insulation Pad - Yellow w/Wire Retainer Kit (See #PD398B) (RE)	49.00/ea.
PD401C	1957	Underhood Insulation Pad - Gray (RE)..	26.00/ea.
PD401D	1957	Underhood Insulation Pad - Gray w/Wire Retainer Kit (See #PD398B) (RE)	46.00/ea.
PD402	1958	Underhood Insulation Pad - Yellow (RE)	28.00/ea.
PD402A	1958	Underhood Insulation Pad - Yellow w/Wire Retainer Kit (See #PD398B) (RE)	49.00/ea.
PD402C	1958	Underhood Insulation Pad - Gray (RE)..	26.00/ea.
PD402D	1958	Underhood Insulation Pad - Gray w/Wire Retainer Kit (See #PD398B) (RE)	44.00/ea.
PD403	1959	Underhood Insulation Pad - Yellow (RE)	29.00/ea.
PD403A	1959	Underhood Insulation Pad - Yellow w/Wire Retainer Kit (See #PD398D) (RE)	52.00/ea.
PD403C	1959	Underhood Insulation Pad - Gray (RE)..	29.00/ea.
PD403D	1959	Underhood Insulation Pad - Gray w/Wire Retainer Kit (See #PD398D)(RE)	52.00/ea.
PD404	1960	Underhood Insulation Pad - Yellow (RE)	29.00/ea.
PD405	1960	Underhood Insulation Pad Yellow w/Clips (See #PD434) (RE)	32.00/ea.
PD405C	1960	Underhood Insulation Pad - Gray (RE)..	29.00/ea.
PD405D	1960	Underhood Insulation Pad - Gray w/Clips (See #PD434) (RE)	32.00/ea.
PD406	1961-62	Underhood Insulation Pad - Yellow (RE)	29.00/ea.
PD407	1961-62	Underhood Insulation Pad - Yellow w/Clips (See #PD434) (RE)	32.00/ea.
PD407C	1961-62	Underhood Insulation Pad - Gray (RE)..	29.00/ea.
PD407D	1961-62	Underhood Insulation Pad - Gray w/Clips (See #PD434) (RE)	32.00/ea.

There seems to be controversy over the color of original hood insulation pads for 56-62 FS Pontiacs. Many customers have found gray hood pads instead of yellow on their early cars. Therefore, we have decided to carry both yellow and gray.

PD408	1963	Underhood Insulation Pad (RE)	29.00/ea.
PD409	1963	Underhood Insulation Pad w/Clips (See #PD436) (RE)	31.00/ea.
PD410	1964	Underhood Insulation Pad (RE)	29.00/ea.
PD411	1964	Underhood Insulation Pad w/Clips (See #PD436) (RE)	31.00/ea.
PD412	1964	Underhood Insulation Pad w/Metal Clips (See #PD435) (RE)	43.00/ea.
PD413	1965	Underhood Insulation Pad (RE)	29.00/ea.

PD414	1965	Underhood Insulation Pad w/Clips (See #PD436) (RE)	\$31.00/ea.
PD415	1965	Underhood Insulation Pad w/Metal Clips (See #PD435) (RE)	42.00/ea.
PD416	1966	Underhood Insulation Pad (RE)	29.00/ea.
PD417	1966	Underhood Insulation Pad w/Clips (See #PD436) (RE)	31.00/ea.
PD418	1966	Underhood Insulation Pad w/Metal Clips (See #PD435) (RE)	42.00/ea.
PD419	1967	Underhood Insulation Pad (RE)	29.00/ea.
PD419A	1967	Underhood Insulation Pad w/Clips (See #PD436) (RE)	31.00/ea.
PD420	1968	Underhood Insulation Pad (RE)	29.00/ea.
PD420A	1968	Underhood Insulation Pad w/Clips (See #PD436) (RE)	31.00/ea.
PD421	1969-70	Underhood Insulation Pad - FS (RE)	29.00/ea.
PD422	1969-70	Underhood Insulation Pad w/Clips (See #PD436) - FS (RE)	31.00/ea.
PD423	1969-70	Underhood Insulation Pad - GP (RE) ...	29.00/ea.
PD424	1969-70	Underhood Insulation Pad w/Clips (See #PD436) - GP (RE)	31.00/ea.
PD425	1971-72	Underhood Insulation Pad - FS (RE)	29.00/ea.
PD426	1971-72	Underhood Insulation Pad w/Clips (See #PD436) - FS (RE)	31.00/ea.
PD427	1971-72	Underhood Insulation Pad - GP (RE) ...	29.00/ea.
PD428	1971-72	Underhood Insulation Pad w/Clips (See #PD436) - GP (RE)	31.00/ea.
PD428D	1971-72	Underhood Insulation Pad - Grandville (RE)	29.00/ea.
PD428E	1971-72	Underhood Insulation Pad w/Clips (See #PD436) - Grandville (RE)	31.00/ea.
PD428J	1973-74	Underhood Insulation Pad - FS (RE)	32.00/ea.
PD428K	1973-74	Underhood Insulation Pad w/Clips (See #PD436) - FS (RE)	34.00/ea.
PD429	1973-77	Underhood Insulation Pad - GP (RE) ...	29.00/ea.
PD429A	1973-77	Underhood Insulation Pad w/Clips (See #PD436) - GP (RE)	31.00/ea.
PD429D	1975	Underhood Insulation - FS (RE)	32.00/ea.
PD429E	1975	Underhood Insulation w/Clips (See #PD436) - FS (RE)	34.00/ea.
PD429F	1975	Underhood Insulation - Bonneville & Grandville (RE)	32.00/ea.
PD429G	1975	Underhood Insulation w/Clips (See #PD436) - Bonneville & Grandville (RE)	34.00/ea.



PD434

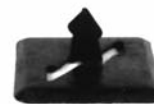

PD435



PD436

PD434	1960-62	Hood Insulator Pad Clip, Round Plastic (RE)	1.00/ea.
PD435	1964-66	Hood Insulator Pad Clip, Square Metal (RE)	1.50/ea.
<p>PD435 is a steel hood pad clip for those restorers seeking originality. Gauge, type of steel, and black finish are all the same as original.</p>			
PD436	1963-77	Hood Insulator Pad Clip, Square Plastic (RE)	.50/ea.

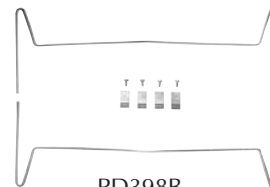

PD398B

PD398	1956	Hood Pad Wire Retainer Kit (APE)	20.00/kit
<p>This kit includes 2 stainless steel retaining wires, 4 stamped clips and 4 screws to hold your hood pad securely in place.</p>			
PD398B	1957-58	Hood Pad Wire Retainer Kit (APE)	22.00/kit
PD398D	1959	Hood Pad Wire Retainer Kit (APE)	27.00/kit
<p>PD398B and PD398D include 2 galvanized retaining wires, 4 stamped clips and 4 screws.</p>			

HOOD COMPONENTS

DOOR COMPONENTS

EMBLEMS



PF100

PF100 1955 Chrome Star Ornament (RE)..... \$15.00/ea.



PF100B

PF100B 1955-56 "Safari" Door Emblem (RE) 49.00/ea.



PF100D

PF100D 1956 "StarChief" Door Emblems (2 Piece Set) (RE) 52.00/set

Note: "Star" and "Chief" are separate emblems. Requires two sets per car.



PF100J

PF100J 1959 Bonneville Door Crest Emblem (RE)..... 23.00/ea.



PF100L

PF100L 1959 Bonneville Rear Door Ornament, LH or RH, 4 Doors (RE)..... 35.00/ea.

Also see PJ102H for rear 1/4 ornaments. Requires a total of 8 pieces. Quality; Fair to good.



PF104

PF104 1961 "Bonneville" Door Letters (10 Pieces) (RE) 179.00/set

Requires two sets per car.



PF105

PF105 1962 Door Emblem - GP (RE)..... Disc.

Comments: PF105 is not die-cast. This piece is a low pressure casting, and overall the quality is good.



PF106J

PF106J 1966 Bonneville Door and Fender Letters (10 pc. set) (RE) \$113.00/ea

DOOR HANDLES



PF121D

PF110 1955-57 Outside Door Handle Assembly - 2 Dr. HT & CVT (RE)..... 95.00/pr.

PF111 1955-57 Outside Door Handle Assembly Sedan - 4 Dr. HT (RE)..... 95.00/pr.

PF115 1958 Outside Door Handle Assembly (RE).... 135.00/pr.

Note: PF115 will not fit Chieftain & Superchief 2 Dr. HT & 4 Dr. Sedan.

PF117 1959 Outside Door Handle Assembly - Front (RE)..... 95.00/pr.

PF120D 1959 Rear & 1967-68 Front or Rear Outside Door Handle Assembly (RE) 85.00/pr.

PF110-PF120D assemblies include handles, buttons, shafts, springs, o-rings, retainers, bolts and gaskets.

PF121D 1960-62 Front & 1961-62 Rear Outside Door Handle Assembly (RE) 85.00/pr.

Note: Includes same components as PF120D.

PF122D 1960 Rear & 1963-66 Front or Rear Outside Door Handle Assembly (RE).... 85.00/pr.

Note: Includes same components as PF120D.

Comments: PF122D handles exhibit excellent quality.



PF127S

PF127S 1969-72 Outside Door Handle Assembly w/o Retainer, LH or RH - GP (RE) 51.00/ea.

PF127T 1969-72 Outside Door Handle Assembly, Pair w/o Retainers - GP (RE) 97.00/pr.

Quality of chrome of PF127S and PF127T is considered good.

See PF144A for door handle gaskets.

PF128 1971-76 Outside Door Handles, Front or Rear - FS (GM) 235.00/pr.

PF128C 1971-76 Outside Door Handles, Front or Rear 6 3/16" Long - FS (RE) 69.00/pr.

PF128C is a less expensive alternative to PF128. PF128C is also more correct than PF128 as they are the longer handles used during early years.

PF130 Late 1976-77
 Outside Door Handles, 5 5/8" long
 - GP (GM)..... Disc.
 1976 was a transition year for door handles. Please measure your originals before ordering.



PF130AL Late 1976-77
 Outside Door Handles, 5 5/8" long, LH
 - GP (AP)..... \$35.00/ea.

PF130AR Late 1976-77
 Outside Door Handles, 5 5/8" long, RH
 - GP (AP)..... 35.00/ea.



PF135

PF133 1955-57 Outside Door Handle Push Buttons (RE) Disc.
PF135 1960-70 Outside Door Handle Buttons (RE)..... 23.00/pr.

Comments: These reproductions far exceed the current GM door handle button quality. Buttons come complete with gaskets, springs and retainers. Button shafts must be cut to fit your application.

DOOR HANDLE SHIELDS

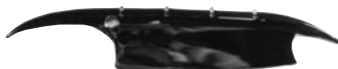

PF140

PF140 1955-56 Accessory Door Handle Shields (RE) ... 54.00/pr.



PF141

PF141 1957 Accessory Door Handle Shields (RE) 54.00/pr.

DOOR HANDLE GASKETS



PF144

PF142 1955-57 Door Handle and Lock Gaskets (RE) 5.00/set
PF143 1958 Door Handle and Lock Gaskets (RE) 4.00/set
PF143A 1959 Rear and 1967-68 All Door Handle and Lock Gaskets (RE) 5.50/set
PF144 1959-70 Door Handle and Lock Gaskets (Exc. 1959 Rear, 1967-68, and '69-'72 GP) (RE) 5.50/set
PF144A 1969-72 Door Handle and Lock Gaskets - GP (RE) 7.00/set

Set includes enough gaskets for two door handles and three locks.

Comments: Excellent. Other sources sell beaded gaskets, but we've never seen these used by the factory.



PF144F

PF144F 1971-76 FS & 1973-77 GP
 Outside Door Handle Escutcheon (GM) \$6.00/ea.

This is the black plastic behind the outside door handle that serves as a gasket and a water shield.

PF144N 1955-77 Door and Deck Lid Lock Gasket (RE) ... 1.50/ea.

DOOR BADGES



PF144TB

PF144TA 1967 Mark of Excellence Badge, Turquoise (RE) 4.00/ea.

PF144TB 1968 & Newer Mark of Excellence Badge, Blue (RE) 5.00/ea.

PF144TB are correct stamped aluminum pieces. They have a self adhesive backing.

Comments: Quality is excellent.

DOOR LOCK ASSEMBLIES



PF145A 1955-57 Door Lock Assembly (Sedans w/Late-Style Key (NOS) 29.00/pr.
PF145B 1955-57 Door Lock Assembly (Sedans w/Original-Style Key (NOS)..... 36.00/pr.
PF146A 1955-57 Door Lock Assembly (2 Dr. HT and Conv.) w/Late-Style Key (NOS) 29.00/pr.
PF146B 1955-57 Door Lock Assembly (2 Dr. HT and Conv.) w/Original-Style Key (NOS) 36.00/pr.
PF147A 1956-57 Door Lock Assembly (4 Dr. HT) w/Late-Style Key (NOS) 26.00/pr.
PF147B 1956-57 Door Lock Assembly (4 Dr. HT) w/Original-Style Key (NOS)..... 35.00/pr.
PF148A 1958 Door Lock Assembly (Exc. Wagons) w/Late-Style Key (NOS) Disc.
PF148B 1958 Door Lock Assembly (Exc. Wagons) w/Original-Style Key (NOS)..... Disc.
PF149A 1958 Door Lock Assembly (Wagons) w/Late-Style Key (NOS) Disc.
PF149B 1958 Door Lock Assembly (Wagons) w/Original-Style Key (NOS)..... Disc.
PF150A 1959 Door Lock Assembly (All 2 Dr. Models) w/Late-Style Key (NOS) Disc.
PF150B 1959 Door Lock Assembly (All 2 Dr. Models) w/Original-Style Key (NOS) Disc.
PF151A 1959 Door Lock Assembly (All 4 Dr. Models) w/Late-Style Keys (NOS)..... Disc.
PF151B 1959 Door Lock Assembly (All 4 Dr. Models) w/Original-Style Key (NOS) Disc.
PF152A 1960 Door Lock Assembly (All 2 Dr. Models) w/Late-Style Key (NOS) Disc.
PF152B 1960 Door Lock Assembly (All 2 Dr. Models) w/Original-Style Key (NOS) Disc.
PF153A 1960 Door Lock Assembly (All 4 Dr. Models) w/Late-Style Key (NOS) Disc.
PF153B 1960 Door Lock Assembly (All 4 Dr. Models) w/Original-Style Key (NOS) Disc.

PF154A	1961-64 Door Lock Assembly (Exc. 4 Dr. HT) w/Late-Style Key (NOS)	\$27.00/pr.
PF154B	1961-64 Door Lock Assembly (Exc. 4 Dr. HT) w/Original-Style Key (NOS).....	45.00/pr.
PF155A	1961-64 Door Lock Assembly (4 Dr. HT) w/Late-Style Key (NOS)	26.00/pr.
PF155B	1961-64 Door Lock Assembly (4 Dr. HT) w/Original-Style Key (NOS).....	35.00/pr.
PF156A	1965-66 Door Lock Assembly w/Late-Style Key (NOS)	20.00/pr.
PF156B	1965-66 Door Lock Assembly w/Original-Style Key (NOS)	25.00/pr.
PF157A	1967-68 Door Lock Assembly w/Late-Style Key (NOS)	20.00/pr.
PF157B	1967-68 Door Lock Assembly w/Original-Style Key (NOS)	25.00/pr.
PF158	1969-70 Door Lock Assembly w/Key - All (NOS)	20.00/pr.
PF159	1971-73 Door Lock Assembly w/Key - FS (NOS)	20.00/pr.
PF159A	1971-73 Door Lock Assembly w/Key - GP (NOS)	20.00/pr.
PF161	1974-76 Door Lock Assembly w/Key - FS (NOS)	20.00/pr.
PF161A	1974-77 Door Lock Assembly w/Key - GP (NOS)	18.00/pr.

Note: Sets of locks using the same key configuration are available in the miscellaneous section.

DOOR LOCK RETAINERS & PAWLS



	PF164A		PF164C	
PF164A	1955-57 Door Lock Retainer 2 Dr HT, CVT, 4 Dr Sedan, and 4 Dr Wagons (RE)	7.00/ea.		
PF164C	1955-57 Door Lock Retainer 2 Dr Sedan, 2 Dr Wagons, and 4 Dr HT (RE)	7.00/ea.		



PF165	Door Lock Retainer - All (RP)	1.00/ea.
--------------	-------------------------------------	----------

PF165 is the clip that holds the door lock assemblies in place in the door. Will not work on 1961-64 cars.

PF170L	1965-66 Door Lock Pawl, LH (All exc. 4 Dr.) (RE)	4.50/ea.
PF170R	1965-66 Door Lock Pawl, RH (All exc. 4 Dr.) (RE)	4.50/ea.



	PF170BL	
PF170BL	1965-66 Door Lock Pawl, LH (4 Dr.) (RE).....	4.50/ea.
PF170BR	1965-66 Door Lock Pawl, RH (4 Dr.) (RE).....	4.50/ea.
PF171L	1967-69 Door Lock Pawl, LH - FS (All exc. 4 Dr.) (RE)	4.50/ea.
PF171R	1967-69 Door Lock Pawl, RH - FS (All exc. 4 Dr.) (RE)	4.50/ea.
PF171BL	1967-69 Door Lock Pawl, LH - FS (4 Dr. exc. 68-69 Catalina) (RE)	4.50/ea.
PF171BR	1967-69 Door Lock Pawl, RH - FS (4 Dr. exc. 68-69 Catalina) (RE)	4.50/ea.
PF171DL	1968-69 Door Lock Pawl, LH- 4 Dr. Catalina (RE)	4.50/ea.
PF171DR	1968-69 Door Lock Pawl, RH -4 Dr. Catalina (RE)	4.50/ea.

PF172L	1970 Door Lock Pawl, LH - FS (All exc. 4 Dr.) (RE)	\$4.50/ea.
PF172R	1970 Door Lock Pawl, RH - FS (All exc. 4 Dr.) (RE)	4.50/ea.
PF172BL	1970 Door Lock Pawl, LH - FS 4 Dr. (RE).....	4.50/ea.
PF172BR	1970 Door Lock Pawl, RH - FS 4 Dr. (RE)	4.50/ea.



PF180L



PF180M



PF141D

PF180L	Late 55-57 Door Latch, LH - HT or CVT Only (RE)	99.00/ea.
PF180M	Late 55-57 Door Latch, RH - HT or CVT Only (RE)	99.00/ea.
PF184L	1968 Door Latch, LH (RE)	75.00/ea.
PF184R	1968 Door Latch, RH (RE)	75.00/ea.
PF179M	1959-77 Door Latch Screw Set 6Pc (RE).....	4.00/ea.
PF185C	1959-77 Door Latch Rod Retainer Clip (RE)	1.00/ea.
PF141D	1969-77 Door Lock Rod Clip - All 2dr. (RE)	2.00/ea.

Note: 2 required per door.

FRONT DOOR HINGES & HARDWARE



PF193

PF191L	1971-76 Upper Door Hinge, LH - FS (GM)	259.00/ea.
PF191R	1971-76 Upper Door Hinge, RH - FS (GM)	245.00/ea.
PF191TL	1971-76 Upper Door Hinge, LH - FS (RE).....	47.00/ea.
PF191TR	1971-76 Upper Door Hinge, RH - FS (RE)	47.00/ea.

Less expensive alternatives to PF191L & R. Quality: Very good.

PF192	1969-72 Upper Door Hinge, LH or RH - GP (RE)	57.00/ea.
PF193	1969-76 Lower Door Hinge, LH or RH - FS (GM)	175.00/ea.
PF193TS	1969-76 Lower Door Hinge, LH or RH - FS (RE) .	45.00/ea.

Less expensive alternative to PF193. Quality: Very good.

PF194L	1969-72 Lower Door Hinge, LH - GP (RE).....	61.00/ea.
PF194R	1969-72 Lower Door Hinge, RH - GP (RE)	61.00/ea.
PF196	1973-77 Lower Door Hinge, LH or RH - GP (GM)	Disc.
PF197XB	1955-57 Door Hinge to Door Jamb A Pillar Screw Set (8 pcs.) (RE)	6.50/set
PF197XD	1955-57 Door Hinge to Door Bolt Set All 2 Dr and 4Dr Front Doors (12 pcs.) (RE)	9.00/set
PF197XF	1955-57 Door Hinge Screw Set 4 Dr Rear Doors (6 pcs.) (RE).....	5.50/set

Note: PF197XF will do one hinge.



PF198



PF198A

PF198	Phillips Head Door Hinge Bolt (RP).....	2.50/ea.
	This is the correct recessed Phillips head bolt that attaches the hinge to the door.	
PF198A	Hex Head Door Hinge Bolt (RP)	2.50/ea.
	This is the hex bolt that attaches the hinge to the door and/or pillar.	

Note: Please check your hinges for correct application.



PF200

- PF200** 1955-68 Door Hinge Repair Kit (RE) \$18.00/kit
- PF201** 1969-77 Door Hinge Repair Kit, Front (Upper & Lower) (RE) 27.00/kit

Hinge repair kits contain enough hardened pivot pins and bushings for two upper and two lower door hinges.

- PF202** 1955-77 Door Hinge Bushing - 7/16" OD (GM) . 2.00/ea.
- PF202A** 1968-77 Door Hinge Bushing - 1/2" OD (GM) ... 2.00/ea.

DOOR STRIKERS & HARDWARE

- PF204** 1955-59 Door Striker (RE) 49.00/pr..
- PF204AJ** 1955-59 Door Striker to Body Screw Set (6 pcs.) (RE) 6.50/set
- PF204AN** 1955-57 Door Lock Catch Mechanism Screw Set (10 pcs.) (RE) 6.50/set

This attaches the latch mechanism to back of door.



PF204BL

- PF204BL** 1955-57 Door Striker Shim, LH (RE) 7.00/ea.
- PF204BR** 1955-57 Door Striker Shim, RH (RE) 7.00/ea.

Note: Door striker shims are 1/16" thick.



PF204D

- PF204D** 1955-57 Door Striker Lock Plates (Set of 4) (RE) .. 17.00/set

Note: One set per car.

- PF204M** 1964 Door Latch Catch Plates (RE) 95.00/pr.
- PF204M will work on front or rear doors. Aluminum plate does not protrude forward as far as original, but will function the same.



PF204M



PF207

- PF206** 1965-70 Door Striker, LH or RH - FS (GM) 10.00/ea.
- PF206** 1969-72 Door Striker - GP (GM) 10.00/ea.
- PF207** 1965-70 "Original Style" Door Striker, LH or RH - FS (RE) 11.00/ea.
- PF207** 1969-72 "Original Style" Door Striker, LH or RH - GP (RE) 11.00/ea.

This is the original allen-head style striker with the correct length and bushed roller.

- PF208** 1971-76 Door Striker, LH or RH - FS (GM) Disc.
- PF208D** 1965-77 Door Striker Spacer Washer, 1/8" Thick (RP) 1.50/ea.

Use as required.

- PF210D** Allen-Head Impact Bit (For PF208) (AP) 3.00/ea
- PF210F** T-50 Torx-Head Impact Bit (For PF206) (AP) 5.00/ea



PF210D

PF210F



PF208D

RUBBER DOOR BUMPERS



PF226



PF225



PF228

- PF220** 1955-57 Door Bumper (RE) \$3.50/ea.
- PF221** 1955-57 Upper Door Bumper - Sedan (Screw on) (RE) 1.50/ea.

Attaching screw not included.

- PF221A** 1955-57 Upper Door Bumper - Sedan (Plug type) (RE) 3.50/ea.

These have a molded rubber nipple that pushes into a hole.

- PF225** 1958 Door Bumper - 3/8" Tall (GM) 2.00/ea.
- PF226** 1959-62 Door Bumper (RE) 1.50/ea.
- PF226A** 1963-64 Door Bumper (RE) 2.00/ea.
- PF225** 1959-64 Door Bumper (GM) 2.00/ea.

Note: Many 1959-64 full-size cars used PF225 bumpers in conjunction with PF226 (especially four-door models).

- PF225** 1965-66 Door Bumper - 3/8" Tall (GM) 2.00/ea.
- PF228** 1967-70 Door Bumper - FS - 3/4" Tall (RE) 2.50/ea.

Note: These 3/4" x 1" bumpers were usually used as the top bumper on two-door models and also on some four-door models.

- PF225** 1967-77 Door Bumper - FS - 3/8" Tall (RE) 2.00/ea.

Note: These 3/8" x 1" bumpers were used in conjunction with PF228.

- PF225** 1969-77 Door Bumper - GP - 3/8" Tall (GM) 2.00/ea.

DOOR WINDOW STOPS



PF245

- PF245** 1955-57 Door Window Stop Kit CVT and HT (RE) 24.00/ea.

Note: One kit per door. Includes one long stop screw, one short stop screw, plates, rubber caps and necessary attaching hardware.

- PF245B** 1958 Door Window Stop Kit CVT and HT (RE) 25.00/ea.

Note: One kit per door. Includes two stop screws, plates, rubber caps and necessary attaching hardware.

- PF250** 1955-58 Door Window Stop w/Manual Window (RE) 1.50/ea.

- PF251** 1955-60 Door Window Stops w/Power Windows (RE) 4.50/pr.

- PF251B** 1959-60 Door Window Stops Sedan w/o Power Windows (RE) 4.50/ea.

- PF251D** 1961-64 Door Window Stop (RE) 4.50/ea.

- PF251R** 1955-57 Anti-Rattle Window Roller (RE) 4.50/ea.

DOOR DRAIN SEALS



PF252J

- PF252D** 1956-58 Door Drain Seal (RE) 3.50/ea.
- PF252J** 1962-72 Door Drain Seal (RE) 3.50/ea.

Ever wonder what those slots were at the bottom of your doors? These seals pop into the holes at each end of the slots allowing water out and keeping dirt from entering the door.

DOME LIGHT SWITCHES



- | | | | | |
|----------------|---|--|---------|-------------|
| | PF254RB | | PF254RF | |
| PF254RA | 1955-56 Dome Light Door Jamb Switch, Front Doors - 4 Dr. (RE)..... | | | \$25.00/ea. |
| PF254RB | 1955-56 Dome Light Door Jamb Switch, Rear Doors - 4 Dr. (RE)..... | | | 17.00/ea. |
| PF254RE | 1957-60 Dome Light Door Jamb Switch, Front Doors - 4 Dr. (RE)..... | | | 25.00/ea. |
| PF254RF | 1957-60 Dome Light Door Jamb Switch, Rear Doors - 4 Dr. (RE)..... | | | 17.00/ea. |
| PF254RF | 1961-62 Dome Light Door Jamb Switch, Rear Doors - SW (RE)..... | | | 17.00/ea. |
| | PF254RB & RF come complete with gaskets and screws. | | | |
| PF254RR | 1955-56 Dome Light Door Jamb Switch Gasket - All (RE) | | | 1.50/pr. |
| PF254RS | 1957-60 Dome Light Door Jamb Switch Gasket - All (RE)..... | | | 1.50/pr. |
| PF254RS | 1961-62 Dome Light Door Jamb Switch Gasket, Rear Doors - SW (RE)..... | | | 1.50/pr. |



- | | | | | |
|---------------|---|--|--------|----------|
| | PF255L | | PF255M | |
| PF255L | 1968-77 Dome Light Door Jamb Switch, 2-Terminal (AP)..... | | | 7.00/ea. |
| PF255M | 1968-77 Dome Light Door Jamb Switch, 1-Terminal (AP)..... | | | 7.00/ea. |

1955-63 MIRRORS & COMPONENTS



- PF257E** 1955-56 Outside Rearview Mirror w/ Mounting Hardware (RP)..... 37.00/ea.

Note: **(This is not like original)** This is a replacement that has a similar appearance to original. Comes complete with mounting hardware and instructions.

Quality: Chrome is good.



- PF258** 1955-56 Outside Rearview Mirror Pad (RE)..... 3.50/ea.



- PF258J** 1957-58 Outside Rearview Mirror (RE) Disc.



- PF259** 1959-62 Outside Rearview Mirror, w/ Mounting Hardware, LH or RH (RP) \$59.00/ea.

Note: **This is not like original.** This is a replacement that has a similar appearance to original. Comes complete with mounting hardware and instructions.

Quality: Chrome is good.

- PF260** 1959-60 Outside Rearview Mirror Pad (RE)..... 6.50/ea.
PF260B 1961-62 Outside Rearview Mirror Pad (Std. mirror) (RE)..... 6.50/ea.



- PF261J** 1961-63 Outside Rearview Mirror Pad (Remote) (RE)..... 6.00/ea.

1964-68 MIRRORS & COMPONENTS



- PF269J** 1964-66 Outside Rearview Mirror w/Pad, Bracket & Screws, RH or LH, Std. (APE) 47.00/ea.

PF269J is an exact high quality reproduction of the original 1964-66 mirror part number 9770283. In-house durability and testing have proven the quality and originality of these mirrors to be far better than that of the mirrors GM previously offered.



- PF269K** 1964-66 Outside Rearview Mirror Pad (APE)..... 4.00/ea.

Note: This is the pad that comes with PF269J. If you are ordering a pad for an existing mirror on your car, check the casting number under the base. The original '64-'66 mirrors should have a base casting number of 1164573. Replacement mirrors should have base casting numbers of 15-1548 or 61076 (for these applications use PF270A).

- PF269R** 1964 Fender Mount Remote Mirror Hdw. (RE) 12.00/ea.

- PF270** 1967-68 Outside Rearview Mirror w/Pad, Bracket & Screws, RH or LH, Std. (APE) 47.00/ea.

Comments: PF270 is an exact reproduction of the 67-68 mirror - part number 9787901.

- PF270A** 1967-68 Outside Rearview Mirror Pad (APE)..... 4.00/ea.

This is the pad that comes with PF270. If you are ordering this pad for an existing mirror check to see that the base casting numbers are either 15-1548 or 61076 and refer to notes under PF269K.



PF270F

- PF270B** 1964-68 Outside Rearview Mirror Bracket (Std.) (APE) \$5.00/ea.
- PF270C** 1964-68 Outside Rearview Mirror Attaching Screw (Std.) (GM) 1.50/ea.
- PF270F** 1964-66 Mirror Hardware Combo (APE) 8.00/ea.
- PF270K** 1967-68 Mirror Hardware Combo (APE) 8.00/ea.
- PF270R** 1965-68 Chrome Remote Mirror (RE) 189.00/ea.



PF271



PF271B

- PF271** 1965-68 Outside Rearview Mirror Pad (Remote) (RE) 8.00/ea.

Our correct plastic reproduction PF271 pad is no longer available. This new piece is made of rubber. Quality is good.

- PF271B** 1965-68 Outside Rearview Mirror Bracket (Remote) (RE) 18.00/ea.
- PF271K** 1964-70 Inside Remote Mirror Knob (RE) 15.00/ea.

1969-72 MIRRORS & COMPONENTS



PF272

- PF272** 1969-70 Outside Rearview Mirror w/Pad, Bracket & Screws (RH or LH) (Std.) Chrome - All (APE) 47.00/ea.
- PF272** 1971-72 Outside Rearview Mirror w/Pad, Bracket & Screws (RH or LH) (Std.) Chrome - GP (APE) 47.00/ea.

PF272 has become the standard of the industry with superb chrome, tight construction, and fair price.

Quality: Excellent

- PF272A** 1969-72 Mounting Pad for PF272 (APE) 4.00/ea.
- PF272B** 1969-72 Mounting Bracket for PF272 (APE) 4.00/ea.
- PF272C** 1969-72 Attaching Screw for PF272 1.50/ea.
- PF272D** 1969-72 Attaching Hardware Combination for PF272 (APE) 8.00/kit

Note: PF272D consists of PF272A, PF272B, and PF272C.



PF272DR

- PF272DR** 1969-70 FS & 1969-72 GP Chrome Remote Mirror, LH (RE) 203.00/ea.

Note: Comes with pad. Differences from the original: The control knob is the 1971-72 style and the mirror head attaching screw is not the correct chrome oval head, this one is flat.

Quality: Very Good.

- PF272A** 1969-70 FS & 1969-72 GP Remote Mirror Pad (Chrome Mirror) (APE) 4.00/ea.
- PF273B** 1971-72 Standard Mirror Bracket (GM) 13.00/ea.
- PF273C** 1971-72 Standard Mirror Attaching Screw (RE) ... 1.50/ea.



- PF274** 1971-72 Remote Sport Mirror, LH - GP (RE) \$129.00/ea.
- PF274C** 1971-72 Sport Mirror, RH - GP (RE) 99.00/ea.

Quality of PF274 & PF274C is very good.

- PF275A** 1971-72 Sport Mirror Mounting Pad (GM) 7.00/ea.
- PF275AL** 1971-72 Sport Mirror Bracket, LH (RE) 8.00/ea.
- PF275B** 1971-72 Sport Mirror Mounting Bracket, RH (RE) 8.00/ea.
- PF275C** 1971-72 Sport Mirror to Bracket Screw (RE) 2.00/ea.

WINDOW REGULATOR HANDLES



PF290T

- PF290R** 1965-66 Interior Door and Window Handle Kit 2Dr. Exc. Bonne & GP (RE) 92.00/kit
- PF290T** 1967 Interior Door and Window Handle Kit 2Dr. Exc. Bonne & GP (RE) 80.00/kit
- PF290V** 1968-70 Interior Door and Window Handle Kit 2Dr. Exc. Bonne & GP (RE) 65.00/kit



PF289A



PF289C

- PF289A** 1955-57 Front Window Regulator Handles w/Washers (RP) 29.00/pr.
- PF289C** 1955-57 Front Vent Window Regulator Handles w/Washers (RP) 32.00/pr.

These handles are meant to be used as replacements only. They are chrome-plated and utilize a black knob.



PF289H



PF289J

- PF289H** 1958-64 Front Window Regulator Handle, '58 exc Chieftain, '59-'64 Catalina (AP) 6.00/ea.

Note: This handle is a replacement. It has ribs on the handle where originals did not.

- PF289J** 1958-64 Front Vent Window Regulator Handle, '58 exc Chieftain, '59-'64 Catalina (AP) 6.00/ea.

See note under PF289H.

Window regulator handles continue on next page.

DOOR COMPONENTS

Window regulator handles continued.



- | | | | |
|---------------|---|--------|--------------|
| | PF290 | PF290B | |
| PF290 | 1959-64 Front Window Regulator Handle - Exc. Catalina (RE) | | \$ 13.00/ea. |
| PF290B | 1959-64 Front Vent Window Regulator Handle - Exc. Catalina (RE) | | 13.00/ea. |

PF290 and PF290B are excellent reproductions.

- | | | | |
|--------------|--|--|-----------|
| PF291 | 1965-66 Front Window Regulator Handle - All (GM) | | 88.00/ea. |
|--------------|--|--|-----------|

Comments: This handle exhibits a poor quality finish. We suggest using only if GM is a must.

- | | | | |
|---------------|---|--|-----------|
| PF291G | 1965-66 Front Window Regulator Handle, All (RE) | | 19.00/ea. |
|---------------|---|--|-----------|

This is an excellent alternative to the high-priced poor quality GM handle offered above.

- | | | | |
|---------------|---|--|-------|
| PF291J | 1965-66 Front Vent Window Regulator Handle - All (RE) | | Disc. |
|---------------|---|--|-------|



- | | | | |
|---------------|--|-------|-----------|
| | PF291K | PF292 | |
| PF291K | 1967 Front and Rear Window Regulator Handle, Black Knob (RE) | | 11.00/ea. |

This is a very good reproduction of the 1967 only regulator handle. Available in black only.

- | | | | |
|---------------|--|--|-----------|
| PF291N | 1967 Front Vent Window Regulator Handle, Black Knob (RE) | | 12.00/ea. |
|---------------|--|--|-----------|

- | | | | |
|--------------|--|--|-----------|
| PF292 | 1968-77 Front Window Regulator Handle, Black Knob - All (GM) | | 36.00/ea. |
|--------------|--|--|-----------|

- | | | | |
|---------------|--|--|----------|
| PF292K | 1968-77 Front Window Regulator Handle, Black Knob - All (AP) | | 5.00/ea. |
|---------------|--|--|----------|

- | | | | |
|--------------|--|--|-------|
| PF293 | 1968-77 Front Window Regulator Handle, Clear Knob - All (GM) | | Disc. |
|--------------|--|--|-------|

- | | | | |
|---------------|--|--|----------|
| PF293K | 1968-77 Front Window Regulator Handle, Clear Knob - All (AP) | | 5.00/ea. |
|---------------|--|--|----------|

Note: Although not an exact replacement, we have found the GM window regulator handles to be the best quality handles produced. We also offer PF292K and PF293K as an inexpensive alternative. These also will fit 1967 but have the incorrect knob design.

All regulator handles come with a retainer clip.



- | | | | |
|--------------|---|--------|-----------|
| | PF296 | PF296L | |
| PF296 | 1968 Vent Window Regulator Handle, Black (RE) | | 10.50/ea. |

This is the correct short handle used for 1968 vent window only. Available in black only.

- | | | | |
|----------------|---|--|------------|
| PF296AL | 1959-60 Vent Window Regulator LH (RE) | | 145.00/ea. |
|----------------|---|--|------------|

- | | | | |
|----------------|---|--|------------|
| PF296AR | 1959-60 Vent Window Regulator RH (RE) | | 145.00/ea. |
|----------------|---|--|------------|

- | | | | |
|----------------|---|--|-----------|
| PF296BL | 1961-64 Vent Window Regulator LH (RE) | | 79.00/ea. |
|----------------|---|--|-----------|

- | | | | |
|----------------|---|--|-----------|
| PF296BR | 1961-64 Vent Window Regulator RH (RE) | | 79.00/ea. |
|----------------|---|--|-----------|

- | | | | |
|---------------|---|--|-----------|
| PF296L | 1968 Vent Window Regulator LH, Bonne 2Dr. HT or CVT & Cat CVT w/Custom Trim (RE) | | 53.00/ea. |
|---------------|---|--|-----------|

- | | | | |
|---------------|---|--|-----------|
| PF296R | 1968 Vent Window Regulator RH, Bonne 2Dr. HT or CVT & Cat CVT w/Custom Trim (RE) | | 53.00/ea. |
|---------------|---|--|-----------|



- | | | | |
|--------------|---|--|------------|
| | PF295 | | |
| PF295 | 1967-77 Window Regulator Handle Replacement Knob (AP) | | \$7.00/pr. |

Although colored knobs are not original for '68 and up, these are an attractive accessory for daily driver cars.

Colors available are: black, white, red, and medium blue.

Note: Only to be used on an original window crank handle.



- | | | | | |
|---------------|---|-------|--------|----------|
| | PF298 | PF299 | PF299D | PF299DB |
| PF298 | Door Panel Sealing Foam Washer (RE) . | | | 4.50/pr. |
| PF299 | 1955-77 Window Regulator Handle Washer - All (GM) | | | 6.00/ea. |
| PF299A | 1955-77 Window Regulator Handle Washer - All (RE) | | | 1.50/ea. |
| PF299D | 1961-77 Window Regulator Handle Spring (RE) | | | 1.50/ea. |
- These are the springs behind the window regulator handles and door handles.
- | | | | | |
|----------------|--|--|--|----------|
| PF299DB | 1961-77 Window Regulator Handle Retainer Clip (RP) | | | 1.00/ea. |
|----------------|--|--|--|----------|



- | | | | |
|--------------|---|--|----------|
| | PF300 | | |
| PF300 | 1959-77 Regulator and Door Handle Spring Clip Removal Tool (AP) | | 5.50/ea. |

WINDOW ROLLERS



- | | | | |
|----------------|--|---------|-----------|
| | PF299DJ | PF299DZ | |
| PF299DJ | 1955-57 Window Regulator Roller w/ 1/4" Rivet (RE) | | 3.50/ea. |
| PF299DK | 1955-57 Window Regulator Roller w/ 5/16" Rivet (RE) | | 3.50/ea. |
| PF299DZ | 1955-57 Front Door Window Anti-Rattle Roller HP - CVT, Safari (RE) | | 12.00/ea. |



- | | | | |
|---------------|--|--|-----------|
| | PF299J | | |
| PF299J | 1969-70 Front Window Regulator Rear Roller - GP (RE) | | 5.00/ea. |
| PF299T | 1969-72 Door Glass Stabilizers - GP (RE) | | 11.00/pr. |

DOOR COMPONENTS

WINDOW REGULATORS & COMPONENTS



PF302CA

- PF302CA** 1955-57 Manual Window Regulator Assembly
LH - 2 Dr. HT and CVT (RE) \$135.00/ea.
- PF302CB** 1955-57 Manual Window Regulator Assembly
RH - 2 Dr HT and CVT (RE) 135.00/ea.
- PF302CE** 1955-57 Manual Front Window Regulator
Assembly, LH - Sedan and SW (RE) 135.00/ea.
- PF302CG** 1955-57 Manual Front Window Regulator
Assembly, RH - Sedan and SW (RE)..... 135.00/ea.
- PF303F** 1969 Manual Window Regulator, LH - GP (RE) 72.00/ea.
- PF303G** 1969 Manual Window Regulator, RH - GP (RE) 72.00/ea.
- PF303L** 1970-72 Manual Window Regulator, RH - GP (RE) 89.00/ea.
- PF303M** 1970-72 Manual Window Regulator, RH - GP (RE) 89.00/ea.



PF302JA



PF302JJ

- PF302JA** 1955-57 Front Window Regulator Gear
Plate - 2 Dr. HT & CVT (RE)..... 23.00/ea.
- PF302JJ** 1955-64 Window Regulator to Door Frame
Screws (8 pcs.) (RE)..... 5.50/set

These correct-style screws mount the window regulator to the door.

POWER WINDOW MOTORS

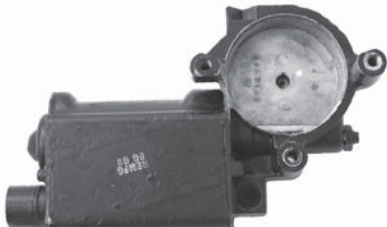

- PF305L** 1955-58 Front Power Window Motor
- LH (RP) 92.00/ea.
- PF305R** 1955-58 Front Power Window Motor
- RH (RP) 92.00/ea.

Note: These motors are replacements for 1955 to 1958 Pontiacs with 12-tooth drive gears.

- PF306L** 1959-71 Front Power Window Motor
- LH (RE) 92.00/ea.
- PF306R** 1959-71 Front Power Window Motor
- RH (RE) 92.00/ea.
- PF307L** 1972-77 Front Power Window Motor
- LH (RE) 92.00/ea.
- PF307R** 1972-77 Front Power Window Motor
- RH (RE) 92.00/ea.

Note: PF306 & PF307 motors have a 12-tooth drive gear. Please check your gear before ordering since some full-size cars used a different number of drive gear teeth.

POWER WINDOW HARNESS BOOT



PF308J

- PF308J** 1965-68 Power Window Harness Boot (RE) \$74.00/pr.

INSIDE DOOR HANDLES



PF309N

- PF309H** 1955-58 Inside Door handles (RP) 26.50/pr.
- PF309N** 1955-58 Inside Door Handles w/Washers (RE-RP) 25.00/pr.

Excellent quality.

Note: These are meant to be used as replacements. They are not exact.

- PF309NA** 1955-58 Inside Door Handles (AP-RP) 6.00/ea.
These are A less expensive fair quality alternative to PF309N. They do not include the washer.

- PF309H** 1959-64 Inside Door Handles exc. Catalina (RP) 26.50/pr.
- PF309N** 1959-64 Inside Door Handles w/Washers
- Catalina Only (RE-RP)..... 25.00/pr.

Excellent quality.

Note: These are meant to be used as replacements. They are not exact.

- PF309NA** 1959-64 Inside Door Handles
- Catalina Only (AP-RP) 6.00/ea.

These are A less expensive fair quality alternative to PF309N. They do not include the washer.



PF310D

- PF310D** 1959-64 Inside Door Handle - Exc. Catalina (RE) 11.00/ea.



PF310X

- PF310X** 1965-67 Inside Door Handle - GP &
Bonneville (RE) 39.00/pr.

Comments: Excellent.

DOOR COMPONENTS



PF311

- PF311** 1965-67 Inside Door Handle
- Exc. Bonneville -GP (GM)..... \$43.00/ea.
- PF311A** 1965-67 Inside Door Handle
- Exc. Bonneville -GP (RE)..... 12.00/ea.



PF315L

PF315R

- PF315L** 1968-70 Inside Door Handle, LH - Exc. GP & Bonneville(GM) 68.00/ea.
- PF315R** 1968-70 Inside Door Handle, RH - Exc. GP & Bonneville(GM) 68.00/ea.
- PF316L** 1968-70 Inside Door Handle, LH - Exc. GP & Bonneville(RE) 16.00/ea.
- PF316R** 1968-70 Inside Door Handle, RH - Exc. GP & Bonneville(RE) 16.00/ea.
- PF321L** 1973-77 Inside Door Handle, LH - GP (GM) Disc.



PF330

- PF330** 1955-67 Inside Door Handle Washer - All (GM). 6.00/ea.
- PF330A** 1955-67 Inside Door Handle Washer - All (RE)... 1.50/ea.



PF330CL



PF330CN

- PF330CL** 1955-57 Inside Door Latch Mechanism, LH (RE) 20.00/ea.
- PF330CN** 1955-59 Inside Door Latch Mechanism Mounting Screws (8 pcs.)..... 5.50/set



PF330FL

- PF330FL** 1968-70 Interior Door Latch Mechanism, LH (RE) 23.00/ea.
- PF330FR** 1968-70 Interior Door Latch Mechanism, RH (RE) 23.00/ea.
- PF330X** 1968-70 Interior Door Latch Mechanism Bolts (RE) 3.00/ea.



PF330NL

- PF330NL** 1968-69 Inside Door Latch Mechanism, LH - Bonneville(RE) \$31.00/ea.

This will also fit '68 Catalina w/Custom Trim.

- PF330NR** 1968-69 Inside Door Latch Mechanism, RH - Bonneville (RE) 31.00/ea.

This will also fit '68 Catalina w/Custom Trim.

VACUUM OPERATED DOOR LOCK COMPONENTS



PF333JA

- PF333JA** 1965 Vacuum Operated Door Lock Vacuum Canister (RE)..... 51.00/ea.
- PF333JA** 1966-67, 69 Vacuum Operated Door Lock Vacuum Canister - Exc. GP (RE) 51.00/ea.



PF333JC

- PF333JC** 1965-69 Vacuum Operated Door Lock Vacuum Line Valve - All (GM)..... 10.00/ea.

LOCK PULLS & FERRULES



PF334



PF352



PF353



PF353B

- PF334** 1955-58 Door Lock Pull - Chrome Steel (RE) 12.50/ea.
- PF335** 1955-60 Door Lock Pulls - Black (RE) 8.00/pr.
- PF336** 1955-60 Door Lock Pulls - Red (RE) 8.00/pr.
- PF337** 1955-60 Door Lock Pulls - Green (RE) 8.00/pr.
- PF338** 1955-60 Door Lock Pulls - Blue..... 8.00/pr.
- PF339** 1955-60 Door Lock Pulls - Aqua (RE)..... 8.00/pr.
- PF340** 1955-60 Door Lock Pulls - Brown (RE)..... 8.00/pr.
- PF341** 1961-62 Door Lock Pulls - Black (RP) 5.00/pr.
- PF341A** 1961-62 Door Lock Pulls - Red (RE) 5.00/pr.
- PF341B** 1961-62 Door Lock Pulls - Blue (RE) 5.00/pr.
- PF341C** 1961-62 Door Lock Pulls - Off-White (RE)..... Disc.
- PF341D** 1961-62 Door Lock Pulls - Light Saddle (RE)..... 5.00/pr.
- PF341E** 1961-62 Door Lock Pulls - Brown (RE)..... 5.00/pr.
- PF350** 1963-66 Door Lock Pulls - Chrome (RE)..... 5.00/pr.

Note: PF350 is an exact reproduction of the 1965-66 door lock pull. It is the same shape and length as the original. It also replaces the 1963-64 chrome metal door lock pulls.

- PF351** 1963-66 Door Lock Pull - Chrome (RP)..... 3.00/pr.

Note: PF351 is an excellent replacement; the shape is very close to original. However, it is 7/16" longer.

Lock pulls and ferrules continue on next page.

Lock pulls and ferrules continued.

PF352	1967	Door Lock Pull - Chrome (RE)	\$6.00/pr.
PF353	1968-70	Door Lock Pull - Fluted Chrome (RE) ...	5.00/pr.
PF353B	1968-77	Door Lock Pull - Chrome (GM)	10.00/pr.

Note: We have found that 1968-70 Pontiacs use two different styles of door lock pulls. Please refer to diagrams of PF353 and PF353B before ordering.

PF353C	1968	Colored Door Lock Pulls (RE)	9.00/pr.
---------------	------	------------------------------------	----------

PF353C Can also be used on '69-'77 cars.

Colors available are: red, white, brown, saddle, and black.



PF355

PF354J	1961-64	Door Lock Pull Ferrules (RE)	7.50/pr.
PF354L	1965-67	Door Lock Pull Ferrules (RE)	7.50/pr.
PF355	1968-77	Door Lock Pull Ferrule (RE)	2.00/ea.

WEATHERSTRIPS

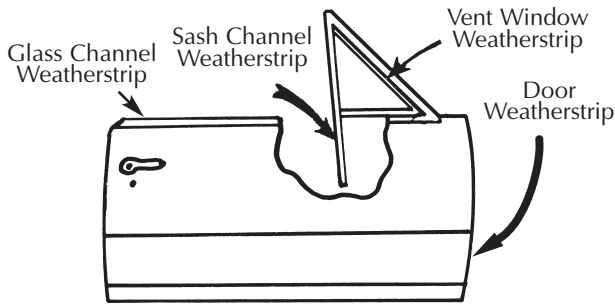

The following few pages contain door-related weatherstripping for your Pontiac. Please refer to this diagram for descriptions of various pieces.

ROOF RAIL WEATHERSTRIP & COMPONENTS

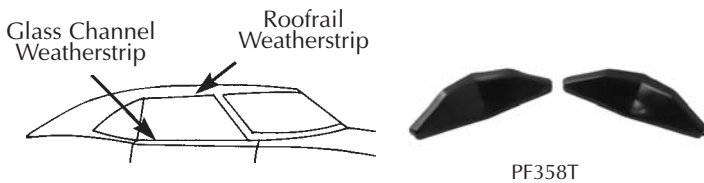

PF358T	1969-72	Window Guides - GP (RE)	15.00/ea.
---------------	---------	-------------------------------	-----------

These guides clip under the drip rail molding escutcheons and guide the glass into the weatherstrip.

PF360	1955-57	Roof Rail Weatherstrip - 2 Dr. HT (RE) ..	15.00/pr.
PF361	1955-57	Roof Rail Weatherstrip - Safari (RE)	125.00/pr.
PF362	1956-57	Roof Rail Weatherstrip - 4 Dr. HT (RE) ..	249.00/pr.
PF363	1958	Roof Rail Weatherstrip - 2 Dr. HT (RE) ..	23.00/pr.
PF364	1958	Roof Rail Weatherstrip - 4 Dr. HT (RE) ..	112.00/pr.
PF366	1959-60	Roof Rail Weatherstrip - 2 Dr. HT (RE) ...	72.00/pr.
PF367	1959-60	Roof Rail Weatherstrip - 4 Dr. HT (RE) ..	112.00/pr.
PF369	1961	Roof Rail Weatherstrip - 2 Dr. HT (RE) ..	72.00/pr.
PF370	1961-62	Roof Rail Weatherstrip - 4 Dr. HT (RE) ..	88.00/pr.
PF371	1962	Roof Rail Weatherstrip - 2 Dr. HT (RE) ...	72.00/pr.



PF373

PF373	1963-64	Roof Rail Weatherstrip - 2Dr. HT (RE)	\$72.00/pr.
PF374	1963-64	Roof Rail Weatherstrip - 4Dr. HT (RE) ...	61.00/pr.
PF374A	1963-64	Roof Rail Weatherstrip - GP (RE)	104.00/pr.
PF375	1965-66	Roof Rail Weatherstrip - 2Dr. HT (RE) ...	61.00/pr.
PF376	1965-66	Roof Rail Weatherstrip - 4Dr. HT (RE) ...	61.00/pr.
PF378	1967-68	Roof Rail Weatherstrip - 2Dr. HT (RE) ...	61.00/pr.
PF378A	1967-68	Roof Rail Weatherstrip - 4Dr. HT (RE) ...	115.00/pr.
PF378C	1967-68	Roof Rail Weatherstrip - GP (RE)	61.00/pr.
PF379A	1969-70	Roof Rail Weatherstrip - FS 4Dr. HT (RE)	61.00/pr.
PF379	1969-70	Roof Rail Weatherstrip - FS 2Dr. HT (RE)	61.00/pr.
PF384	1969-72	Roof Rail Weatherstrip - GP (RE)	59.00/pr.
PF385J	1971-73	Roof Rail Weatherstrip - FS, 2Dr. HT exc. Grandville (RE)	61.00/pr.
PF386	1971-75	Roof Rail Weatherstrip - Grandville, 2Dr. HT (RE)	99.00/pr.
PF386	1974-76	Roof Rail Weatherstrip - Bonneville and Catalina, 2Dr. HT (RE)	99.00/pr.
PF387	1971-74	Roof Rail Weatherstrip - 4Dr. HT exc. Grandville (RE)	152.00/pr.
PF388	1971-74	Roof Rail Weatherstrip - Grandville, 4Dr. HT (RE)	152.00/pr.
PF389A	1973-77	Roof Rail Weatherstrip - GP (RE)	78.00/pr.
PF389L	1973-77	Roof Rail Weatherstrip, LH - GP (GM) ..	Disc.
PF389R	1973-77	Roof Rail Weatherstrip, RH - GP (GM) ..	Disc.

FLIPPER COMPONENTS



PF395

PF395	1955-57	Upper Chrome Flipper Stop at Rear - 2 Dr. HT (RE)	11.00/pr.
--------------	---------	---	-----------



PF395J

PF395J	1955-57	Front Side Roof Rail Filler - 2 Dr. HT (RE)	26.00/pr.
---------------	---------	---	-----------

This filler goes in front of the flipper.

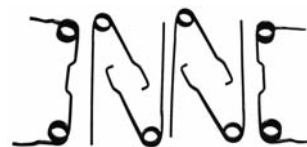

PF395T



PF395TD

PF395T	1955	Flipper Spring Set - 2 Dr. HT (RE)	11.00/set
PF395TA	1956-57	Flipper Spring Set - 2 Dr. HT (RE)	10.00/set

Each set of flipper springs will do one car.

DOOR COMPONENTS

PF395TD 1955-57 Flipper Contact Plastic Cover
 - 2 Dr. HT (RE)..... \$5.50/pr.

Note: This is the piece that slips over the flipper lever that contacts the top of the vent window frame that closes and opens the flipper.

PF395TJ 1955-57 Flipper and 1/4 Window Rooftrack
 Mounting Screws - 2 Dr. HT (40 pcs.) (RE) 5.50/set

GLASS CHANNEL WEATHERSTRIP

Note: As other weatherstrips become available we will evaluate them and include them in future catalogs. Please inquire if you do not see your car listed. Many sedan kits can be made from raw material available. Please inquire.

These weatherstrip kits contain eight horizontal weatherstrips (unless otherwise noted) that seal the bottom of the door glass and rear quarter glass. Both inside and outside weatherstrips are included and sold only as a complete kit (no individual pieces may be purchased separately) unless noted otherwise.

Comments: These weatherstrips do not always have the same design as original equipment. However, they are a good replacement when originals have deteriorated.

PF400 1955-57 Glass Channel Weatherstrip
 - 2 Dr. HT (AP) 89.00/set

PF401 1955-57 Glass Channel Weatherstrip
 - CVT (AP) 89.00/set

PF402 1955-57 Glass Channel Weatherstrip
 - 2 Dr. Sedan (AP)..... 159.00/set

PF403 1955-57 Glass Channel Weatherstrip
 - 4 Dr. Sedan (AP)..... 159.00/set

PF404 1955-57 Glass Channel Weatherstrip
 - Safari (AP)..... 139.00/set

Add \$10.00 oversize fee to standard shipping for PF404.



PF405 1956-57 Glass Channel Weatherstrip
 - 4 Dr. HT (AP) 89.00/set

PF406 1958 Glass Channel Weatherstrip
 - Bonneville HT (AP) 85.00/set

PF407 1958 Glass Channel Weatherstrip
 - Bonneville CVT (AP) 85.00/set

Note: PF400 through PF407 come complete with vertical sash channel weatherstrips.

PF411 1959-60 Glass Channel Weatherstrip
 - 2 Dr. HT (AP) 79.00/set

PF412 1959-60 Glass Channel Weatherstrip
 - CVT (AP) 69.00/set

PF413 1959-60 Glass Channel Weatherstrip
 - 2 Dr. Sedan (AP)..... 69.00/set

Note: PF411 through PF413 are not exact replacements for the original weatherstrip. The stainless steel on the exterior strips is much smaller diameter than original and the original mounting clips are not available.

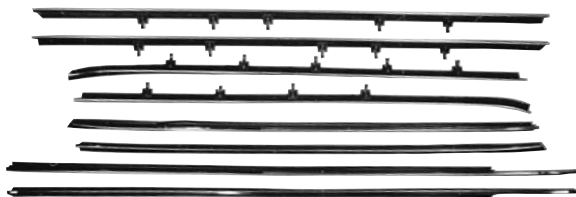

PF415 1961 Glass Channel Weatherstrip Set
 - 2 Dr. HT, 8 pcs. (AP) 79.00/set

PF415A 1961 Glass Channel Weatherstrip Set
 - CVT, 8 pcs. (AP) 75.00/set

PF416 1962-64 Glass Channel Weatherstrip Set
 - 2 Dr. HT, 8 pcs. exc. 63-64 GP (AP)..... 79.00/set

PF416 will fit 1962 Grand Prix.

PF416A 1962 Glass Channel Weatherstrip Set
 - CVT, 8 pcs. (AP) 79.00/set

PF416B 1963-64 Glass Channel Weatherstrip Set
 - CVT, 8 pcs. (AP) \$79.00/set

PF416C 1963-64 Glass Channel Weatherstrip Set
 - GP, 8 pcs. (AP) 85.00/set

PF415 through PF416C do not have the same design as original equipment. Cars will have to be drilled to install these weatherstrips.

PF425 1965-66 Outer Glass Channel Weatherstrip Set
 - 2 Dr. HT Exc. GP, 4 pcs. (RE) Disc.

PF425A 1965-66 Outer Glass Channel Weatherstrip Set
 - CVT, 4 pcs. (RE)..... Disc.

PF435 1965-66 Glass Channel Weatherstrip Set
 - 2 Dr. HT Exc. GP, 8 pcs. (AP)..... 85.00/set

PF435A 1965-66 Glass Channel Weatherstrip Set
 - CVT, 8 pcs. (AP) 79.00/set

PF435C 1965-66 Glass Channel Weatherstrip Set
 - GP, 8 pcs. (AP) 85.00/set

PF435J 1967-68 Glass Channel Weatherstrip Set
 - 2 Dr. HT Exc. GP, 8 pcs. (AP)..... 69.00/set

PF436 1967-68 Glass Channel Weatherstrip Set
 - CVT Exc. GP, 8 pcs. (AP)..... 79.00/set

PF437 1967 Glass Channel Weatherstrip Set
 - 2 Dr. HT - GP, 8 pcs. (AP)..... 85.00/set

PF437A 1967 Glass Channel Weatherstrip Set
 - CVT - GP, 8 pcs. (AP)..... 85.00/set

PF438 1968 Glass Channel Weatherstrip Set
 - GP, 8 pcs. (AP) 85.00/set

PF445 1969-72 Glass Channel Weatherstrip Set
 - GP, 8 pcs. (AP) 85.00/set

PF450 1969-70 Glass Channel Weatherstrip Set
 - 2 Dr. HT - Catalina, 8 pcs. (AP)..... 89.00/set

PF450A 1969-70 Glass Channel Weatherstrip Set
 - Conv. - Catalina, 8 pcs. (AP)..... 89.00/set

PF452 1969-70 Glass Channel Weatherstrip Set
 - 2 Dr. HT - Bonneville, 8 pcs. (AP)..... 89.00/set

PF452A 1969-70 Glass Channel Weatherstrip Set
 - Conv. - Bonneville, 8 pcs. (AP)..... 89.00/set

PF458 1971-72 Outer Glass Channel Weatherstrip Set
 - 2 Dr. HT - FS, w/ Outer Belt Moldings
 4 pcs. (AP) 99.00/set

PF458A 1971-75 Outer Glass Channel Weatherstrip Set
 - CVT - FS, w/ Outer Belt Moldings
 4 pcs. (AP) 99.00/set

PF458AA 1974-76 Outer Glass Channel Weatherstrip Set
 - 2 Dr. HT. - FS, W/ Outer Belt Moldings
 4 pcs. (AP) 95.00/set

PF460 1971-76 Inner Window Glass Channel Weatherstrip
 LH or RH - 2 Dr. HT, FS (RE)..... Inquire

PF466 1973-77 Outer Window Glass Channel Weatherstrip
 -GP, 2 pcs. (RE)..... 99.00/pr.

PF468 1973-77 Inner Window Glass Channel Weatherstrip
 -GP, 2 pcs. (RE)..... 45.00/pr.

GLASS CHANNEL GUIDE PLATES & STAPLES



PF478J 1967-78 Glass Channel Weatherstrip
 Attaching Staples - 20 Pack (RE) 2.00/set



PF480 1962-64 Glass Channel Guide Plate (RE) 7.00/ea.

PF480D 1962-63 Glass Channel Guide Plate (RE) 5.50/ea.

DOOR COMPONENTS

DOOR WEATHERSTRIP FASTENERS



PF498J



PF498L

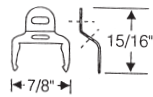

PF498J 1955-60 Door Weatherstrip Fastener (RE) \$1.50/ea.
1/2" long w/ 13/32" head.

PF498L 1955-60 Door Weatherstrip Spring Clip Retainer w/Oval Screw Hole (RE)..... 2.00/ea.

DOOR WEATHERSTRIPS

PF500 1955-57 Door Weatherstrip - 2 Dr. HT & CVT (RE)..... 72.00/pr.
PF501 1955-57 Door Weatherstrip - Safari (RE)..... 61.00/pr.
PF502 1955-60 Door Weatherstrip - 2 Dr. Sedan (RE).... 51.00/pr.
PF503 1955-57 Front Door Weatherstrip - 4 Dr. Sedan (RE) 78.00/pr.
PF503A 1955-57 Rear Door Weatherstrip - 4 Dr. Sedan (RE) 82.00/pr.
PF504 1956-57 Front Door Weatherstrip - 4 Dr. HT (RE)..... 91.00/pr.
PF504A 1956-57 Rear Door Weatherstrip - 4 Dr. HT (RE) 109.00/pr.
PF505 1958 Door Weatherstrip - 2 Dr. HT & CVT (RE)..... 72.00/pr.

Note: This weatherstrip fits Bonneville 2 door hardtop & convertible & Chieftan Convertible only.

PF506 1958 Front Door Weatherstrip - 4 Dr. Sedan (RE) 125.00/pr.
PF506A 1958 Rear Door Weatherstrip - 4 Dr. Sedan (RE) 125.00/pr.
PF510 1959-60 Door Weatherstrip - 2 Dr. HT & CVT (RE)..... 72.00/pr.
PF510F 1959-60 Door Weatherstrip - 2 Dr. Sedan (RE) 115.00/pr.
PF511 1959-60 Front Door Weatherstrip - 4 Dr. Sedan (RE) 89.00/pr.
PF511A 1959-60 Rear Door Weatherstrip - 4 Dr. Sedan (RE) 86.00/pr.
PF511B 1959-60 Rear Door Weatherstrip - 4 Dr. Wagon (RE)..... 89.00/pr.
PF512 1959-60 Front Door Weatherstrip - 4 Dr. HT (RE)..... 93.00/pr.
PF512A 1959-60 Rear Door Weatherstrip - 4 Dr. HT (RE)..... 93.00/pr.
PF515 1961-62 Door Weatherstrip - 2 Dr. HT & CVT (RE)..... 72.00/pr.
PF516 1961-64 Door Weatherstrip - 2 Dr. Sedan (RE) 61.00/pr.
PF516A 1961-62 Front Door Weatherstrip - 4 Dr. Sedan & SW (RE)..... 85.00/pr.
PF517 1963-64 Front Door Weatherstrip - 4 Dr. Sedan & SW (RE)..... 61.00/pr.
PF517A 1961-64 Rear Door Weatherstrip - 4 Dr. Sedan (RE) 61.00/pr.
PF517D 1961-64 Rear Door Weatherstrip - SW (RE) 85.00/pr.
PF518 1961-62 Front Door Weatherstrip - 4 Dr. HT (RE)..... 94.00/pr.
PF518B 1963-64 Front Door Weatherstrip - 4 Dr. HT (RE)..... 94.00/pr.
PF518D 1961-64 Rear Door Weatherstrip - 4 Dr. HT (RE)..... 94.00/pr.
PF520 1963-64 Door Weatherstrip - 2 Dr. HT & CVT exc. GP (RE) 72.00/pr.
PF522 1963-64 Door Weatherstrip- GP (RE) 72.00/pr.
PF525 1965-66 Door Weatherstrip - 2 Dr. Sedan (RE) 61.00/pr.
PF525A 1965-66 Front Door Weatherstrip - 4 Dr. Sedan and SW (RE)..... 61.00/pr.



PF526

PF525B 1965-66 Rear Door Weatherstrip - 4 Dr. Sedan (RE) \$61.00/pr.
PF525D 1965-66 Rear Door Weatherstrip - SW (RE) 61.00/pr.
PF526 1965-66 Door Weatherstrip - 2 Dr. HT & CVT (RE)..... 61.00/pr.
PF527 1965-66 Front Door Weatherstrip - 4 Dr. HT (RE)..... 99.00/pr.
PF527A 1965-66 Rear Door Weatherstrip - 4 Dr. HT (RE)..... 94.00/pr.
PF530 1967-68 Door Weatherstrip - 2 Dr. Sedan (RE) 61.00/pr.
PF530A 1967-68 Front Door Weatherstrip - 4 Dr. Sedan (RE) 61.00/pr.
PF530B 1967-68 Rear Door Weatherstrip - 4 Dr. Sedan (RE) 61.00/pr.
PF530D 1967-68 Front Door Weatherstrip - 4 Dr. HT (RE)..... 99.00/pr.
PF530F 1967-68 Rear Door Weatherstrip - 4 Dr. HT (RE)..... 149.00/pr.
PF531 1967-68 Door Weatherstrip - 2 Dr. HT & CVT exc. GP HT (RE)..... 61.00/pr.
PF531 will fit GP Convertible.
PF531D 1968 Door Weatherstrip - GP (RE) 199.00/pr.
PF533A 1969-70 Front Door Weatherstrip - 4 Dr. Sedan (RE) 92.00/pr.
PF533B 1969-70 Rear Door Weatherstrip - 4 Dr. Sedan (RE) 92.00/pr.
PF535 1969-70 Door Weatherstrip - 2 Dr. HT & CVT, FS (RE)..... 61.00/pr.
PF540 1969-72 Door Weatherstrip - GP (RE) 61.00/pr.
PF542 1971-76 Door Weatherstrip - 2 Dr. HT & CVT - FS (RE) 149.00/pr.
This reproduction is extruded rubber weatherstripping. It is somewhat stiffer than GM's skin-coated latex but it makes a good alternative.
PF544 1971-76 Front Door Weatherstrip - 4 Dr. HT - FS (RE) 132.00/pr.
PF544A 1971-76 Rear Door Weatherstrip - 4 Dr. HT - FS (RE) 105.00/pr.
PF547 1973-77 Door Weatherstrip - GP (RE) 88.00/pr.

SASH CHANNEL WEATHERSTRIP

PF549J 1955-62 Sash Channel Weatherstrip, Front - 2 Dr. HT & CVT (RE)..... 16.00/pr.

Note: 1955-62 Sash Channels use a two-piece weatherstrip. The lower is a galvanized channel while the upper has stainless steel beads. You will receive one of each style which can be cut in half to replace each side.

PF549K 1963 Sash Channel Weatherstrip, Front - 2 Dr. HT & CVT (RE)..... 18.00/pr.
PF549L 1964 Sash Channel Weatherstrip, Front - 2 Dr. HT & CVT (RE)..... 25.00/pr.
PF550 1965-68 Sash Channel Weatherstrip, Front - 2 Dr. HT & CVT (RE)..... 25.00/pr.

PF550 comes with a molded tip like factory originals.

Comments: Very good.

PF550G 1955-68 Front Door Side Glass Rear Sash Channel Weatherstrip - 2 Dr. HT and CVT (RE) 8.00/pr.

This is the flocked weatherstrip used to reline the rear channel on the front door glass.

DOOR COMPONENTS

SASH CHANNEL SIDE WINDOW BUMPERS



PF552AJ

- PF552** 1955-57 Sash Channel Side Window Bumper - 2 Dr. HT, CVT & Safari (RE) \$11.00/pr.
- PF552AJ** 1959-60 Sash Channel Side Window Bumper - All HT (RE) 33.00/pr.
- PF552CJ** 1961-62 Sash Channel Side Window Bumper - 2 Dr. HT (RE) 30.00/pr.
- PF552CK** 1961-62 Sash Channel Side Window Bumper - CVT (RE) 34.00/pr.
- PF552D** 1963-64 Sash Channel Side Window Bumper - 2 Dr. HT (RE) 27.00/pr.
- PF552E** 1963-64 Sash Channel Side Window Bumper - CVT (RE) 27.00/pr.

These bumpers go at the top of the sash channel w/s at the vent window frame and seal the top of the sash channel w/s.

DOOR GLASS SETTING CHANNELS

- PF559** 1955-57 Door Glass Setting Channel - 2 Dr. Sedan (RE) 20.00/set
- PF560** 1955-57 Door Glass Setting Channel - 2 Dr. HT (RE) 22.00/set
- PF561** 1955-57 Door Glass Setting Channel - Safari (RE) 19.00/set
- PF563** 1958-72 Door Glass Setting Channel-.047" (GM) 1.00/ft.

Note: PF559 through PF563 are the rubber channels that hold the glass in the lower sash channel.

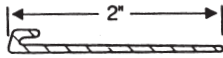

PF569

- PF569** 1965 Door Glass Lower Sash Weatherstrip (RE) 4.00/ft.

For use with cars with bolt-on sash channels.

SASH CHANNELS & SCREWS



PF591

- PF587L** 1955-57 Door Window Glass Lower Sash Channel, LH - 2 Dr. HT & CVT(RE)..... 20.00/ea.
- PF587R** 1955-57 Door Window Glass Lower Sash Channel, RH - 2 Dr. HT & CVT(RE) 20.00/ea.
- PF587AL** 1955-57 Door Window Glass Lower Sash Channel, LH - 2 Dr. Sedan (RE) 20.00/ea.
- PF587AR** 1955-57 Door Window Glass Lower Sash Channel, RH - 2 Dr. Sedan (RE)..... 20.00/ea.

Note: PF587L-PF587AR are zinc-plated to prevent rust and corrosion.

- PF587BL** 1955-57 Door Window Glass Lower Sash Channel, LH - Safari(RE) 15.00/ea.
- PF587BR** 1955-57 Door Window Glass Lower Sash Channel, RH - Safari (RE) 15.00/ea.
- PF587DL** 1955-57 Front Door Window Glass Lower Sash Channel, LH- 4 Dr. Sedan/SW(RE) 13.00/ea.
- PF587DR** 1955-57 Front Door Window Glass Lower Sash Channel, RH - 4 Dr. Sedan/SW(RE) 13.00/ea.
- PF587FL** 1955-57 Rear Door Glass Lower Sash Channel, LH - 4 Dr. Sedan /SW (RE) 13.00/ea.
- PF587FR** 1955-57 Rear Door Glass Lower Sash Channel, RH - 4 Dr. Sedan/SW (RE)..... 13.00/ea.

Note: PF587BL-PF587FR are all painted steel channels.

- PF588L** 1958 Door Window Glass Lower Sash Channel, LH - Bonneville (RE)..... \$68.00/ea.
- PF588R** 1958 Door Window Glass Lower Sash Channel, RH - Bonneville (RE) 68.00/ea.
- PF588AL** 1958 Door Window Glass Lower Sash Channel , LH - Star Chief 2 Dr. HT (RE). 58.00/ea.
- PF588AR** 1958 Door Window Glass Lower Sash Channel, RH - Star Chief 2 Dr. HT (RE) . 58.00/ea.
- PF589L** 1959-60 Door Window Glass Lower Sash Channel, LH - 2 Dr. HT & CVT (RE)..... 69.00/ea.
- PF589R** 1959-60 Door Window Glass Lower Sash Channel, RH - 2 Dr. HT & CVT (RE) 69.00/ea.
- PF589AL** 1959-60 Door Window Glass Lower Sash Channel, LH - 2 Dr. Sedan(RE) Inquire
- PF589AR** 1959-60 Door Window Glass Lower Sash Channel, RH - 2 Dr. Sedan(RE)..... Inquire

Note: PF588L through PF589AR are all triple -plated chrome.

- PF591L** 1961-64 Door Window Glass Lower Sash Channel, LH (RE) 67.00/ea.
- PF591R** 1961-64 Door Window Glass Lower Sash Channel, RH (RE) 67.00/ea.

PF591L & PF591R will fit most 1961-64 cars, however most 1963 Grand Prix used a different size sash. These measure approximately 32 1/2" across the glass channel with a 20 3/4" roller channel.

Check your original piece prior to ordering for '63 Grand Prix.



PF593J

- PF593J** 1955-57 Glass Track to Regulator Arm Mounting Screws (10 pcs.) (RE) 3.50/set

These are the correct-style plated Phillips head w/ attached star washer.



PF593K

- PF593K** 1955-57 Window Channel Adjusting Hole Seal (RE) 3.50/pr.

DOOR WINDOW FRAMES & COMPONENTS

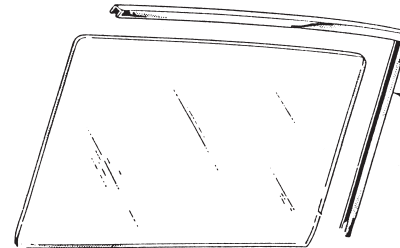

Door Window Frame

- PF595L** 1955-57 Door Window Frame , LH - 2 Dr. HT & CVT (RE) 75.00/ea.
- PF595R** 1955-57 Door Window Frame, RH - 2 Dr. HT & CVT (RE) 75.00/ea.
- PF595DL** 1958 Door Window Frame, LH - Bonneville 2 Dr. HT (RE)..... 75.00/ea.
- PF595DR** 1958 Door Window Frame , RH - Bonneville 2 Dr. HT (RE)..... 75.00/ea.

PF595F	1958	Door Window Frame, LH or RH - Bonneville CVT (RE).....	\$75.00/ea.
PF595HL	1958	Door Window Frame, LH - Star Chief 2 Dr. HT (RE).....	75.00/ea.
PF595HR	1958	Door Window Frame, RH - Star Chief 2 Dr. HT (RE).....	75.00/ea.
PF595KL	1959	Door Window Frame, LH - 2 Dr. HT (RE)	75.00/ea.
PF595KR	1959	Door Window Frame, RH - 2 Dr. HT (RE)	75.00/ea.
PF595M	1959	Door Window Frame, LH or RH - CVT(RE).....	75.00/ea.
PF595PL	1960	Door Window Frame, LH - 2 Dr. HT (RE)	75.00/ea.
PF595PR	1960	Door Window Frame, RH - 2 Dr. HT (RE)	75.00/ea.
PF595S	1960	Door Window Frame, LH or RH - CVT(RE).....	99.00/ea.
PF595XL	1961-64	Door Window Frame, LH - 2 Dr. HT, Exc. GP (RE).....	75.00/ea.
PF595XR	1961-64	Door Window Frame, RH - 2 Dr. HT, Exc. GP (RE).....	75.00/ea.
PF595Y	1961-64	Door Window Frame, LH or RH - CVT (RE).....	75.00/ea.



PF596J

PF596J	1955-57	Window Frame Screw Sets - HT & CVT (RE).....	6.50/set
---------------	---------	---	----------

Contains enough screws to put 4 frames together or one complete car.

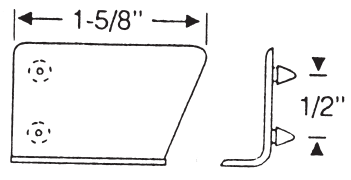

PF599J

PF599J	1961-62	Front Door Hinge Pillar at Beltline Seal - 2 Dr. HT (RE).....	25.00/pr.
---------------	---------	--	-----------

DOOR GLASS

This quality new line of glass is now available at a great price. All glass part numbers are for "clear" glass - **for tinted** glass add a "T" to the end of the part number.



PF555	1955-57	Door Glass LH or RH, 2Dr HT, Clear (RE).....	40.00/ea.
PF555A	1955-57	Door Glass LH or RH, 2Dr Sedan, Clear (RE).....	40.00/ea.
PF555TL	1969-70	Door Glass, Clear LH, GP.....	130.00/ea.
PF555TR	1969-70	Door Glass, Clear RH, GP.....	130.00/ea.
PF555VL	1971-72	Door Glass, Clear RH, GP.....	130.00/ea.
PF555VR	1971-72	Door Glass, Clear RH, GP.....	130.00/ea.

Add \$15.00 oversize fee to standard shipping for door glass.



DOOR HINGE "J" WEATHERSTRIP



PF601

PF600	1955-57	Door Hinge "J" Weatherstrip (RE).....	\$16.00/pr.
PF601	1958	Door Hinge "J" Weatherstrip (RE).....	15.00/pr.
PF602	1959-60	Door Hinge "J" Weatherstrip (RE).....	15.00/pr.

Note: This weatherstrip is used on the front of the door under the windshield pillar post. It keeps water coming off the windshield from entering the interior of the car.

VENT WINDOW GLASS

This quality new line of glass is now available at a great price. All glass part numbers are for "clear" glass - **for tinted** glass add a "T" to the end of the part number.



NOT AN ACTUAL PHOTO

PF604	1955-57	Vent Window Glass 2Dr HT, Clear.....	25.00/ea.
PF604A	1955-57	Vent Window Glass 2Dr Sedan, Clear..	25.00/ea.

VENT WINDOW WEATHERSTRIP & SCREWS

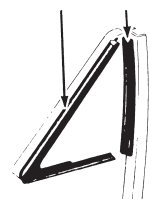

PF605	1955-57	Vent Window Weatherstrip - All HT, CVT & Safari (RE).....	54.00/set
PF606	1955-57	Vent Window Weatherstrip - Sedans & SW (RE).....	54.00/set
PF607	1958	Vent Window Weatherstrip - All Bonneville HT & CVT and 1958 Catalina Convertible (RE).....	54.00/set
PF607C	1958	Vent Window Weatherstrip - Station Wagon (RE).....	118.00/set
PF609	1959-60	Vent Window Weatherstrip - All HT & CVT (RE).....	54.00/set
PF609B	1959	Vent Window Weatherstrip - Sedan & Wagon (RE).....	99.00/set
PF609D	1960	Vent Window Weatherstrip - Sedan & Wagon (RE).....	99.00/set
PF611	1961-62	Vent Window Weatherstrip - All HT & CVT (RE).....	54.00/set
PF611B	1961-62	Vent Window Weatherstrip - Sedan & Wagon (RE).....	106.00/set
PF613	1963-64	Vent Window Weatherstrip - 2 Dr. HT & CVT exc. GP (RE).....	54.00/set
PF613B	1963-64	Vent Window Weatherstrip - 4 Dr. HT, GP (RE).....	112.00/set
PF615	1965-68	Vent Window Weatherstrip - All HT & CVT (RE).....	83.00/set



PF620

- PF620** 1955-57 Vent Window Assembly Screws
- All Exc. Sedans (60 pcs.) (RE)..... \$12.00/set

This kit contains enough chrome-plated screws to install vent moldings, rubber and regulators.



PF622

- PF622** 1955-57 Chrome Vent Window Frames
w/ Latches, HT (RE) 135.00/pr.
PF623 1955-57 Chrome Vent Window Frames
w/o Latches, CVT (RE) 119.00/pr.
PF624 1955-57 Chrome Vent Window Frames
w/ Latches, Sedan and SW (RE) 135.00/pr.



PF625

- PF625** 1955-57 Chrome Vent Window Latches
- Exc. CVT (RE)..... 36.00/ea.
PF628L 1958 Chrome Vent Window Frame, LH- Bonneville
HT & CVT & '58 Catalina CVT (RE)..... 60.00/ea.
PF628R 1958 Chrome Vent Window Frame, RH- Bonneville
HT & CVT & '58 Catalina CVT (RE)..... 60.00/ea.

DOOR SILL PLATES & SCREWS



- PF640** 1955-57 Door Sill Plates - All 2 Dr. (RE)..... \$59.00/pr.
PF641 1955-57 Door Sill Plates - 4 Dr. Sedan (RE)..... 119.00/set
PF642 1956-57 Door Sill Plates - 4 Dr. HT (RE) Disc.
PF643 1958 Door Sill Plates - All 2 Dr. (RE)..... Inquire
PF646 1959-60 Door Sill Plates - All 2 Dr. (RE)..... 119.00/pr.
PF648 1961-64 Door Sill Plates - All 2 Dr. (RE)..... 59.00/pr.
PF648D 1961-64 Door Sill Plates - All 4 Dr., Set of 4 (RE). Disc.

Note: The 1955-57 and 1959-64 door sill plates are excellent reproductions.

- PF650AL** 1965-70 Door Sill Plate, LH - FS (RE)..... 27.00/ea.
PF650AR 1965-70 Door Sill Plate, RH - FS (RE) 27.00/ea.

Quality of PF650AL & PF650AR is Very Good.

- PF650CL** 1965-70 Door Sill Plate, LH - All 2 Dr. (RE)..... 29.00/ea.
PF650CR 1965-70 Door Sill Plate, RH - All 2 Dr. (RE) 29.00/ea.
PF650L 1965-70 Door Sill Plate, LH - FS (GM)..... Disc.
PF650R 1965-70 Door Sill Plate, RH - FS (GM) 69.00/ea.
PF650T 1965-70 Door Sill Plates - All 4 Dr., Set of 4 (RE). 231.00/set
PF651 1971-76 Door Sill Plate, RH or LH
-All 2 Dr.- FS (RE)..... 39.00/ea.
PF654L 1969-72 Door Sill Plate, LH - GP (GM) 82.00/ea.
PF654R 1969-72 Door Sill Plate, RH - GP (GM) 82.00/ea.
PF654H 1969-72 Door Sill Plates, Pair - GP (RE)..... 40.00/pr.
PF655 1973-77 Door Sill Plates, Pair - GP (RE)..... 95.00/pr.
PF656M Body By Fisher Nameplate 2.50/ea.



PF656T

- PF656T** 1955-77 Door Sill Plate Screw Set
(Set of 10) (RE)..... 3.00/set

Note: Order 1 set for 2 door cars and 2 sets for 4 door cars.

BODY SIDE MOLDING CLIPS



PF670

- PF670** Plastic Body Side Molding Clip (RE) 2.00/ea.
Overall dimensions: .330" x .820" Fits .220" x .500" hole.
PF670A Plastic Body Side Molding Clip (RE) 2.00/ea.
Overall dimensions: .435" x .960" Fits .300" x .550" hole.
PF670B Plastic Body Side Molding Clip (RE) 2.00/ea.
Overall dimensions: .600" x .960" Fits .300" x .550" hole.

PF670 - PF670B are used on many different cars. Refer to photo and dimensions for your application.



**Thank you
for shopping with
Ames Performance**

"The Nations Largest Supplier of Pontiac Parts"

ROCKER PANEL MOLDINGS & CLIPS

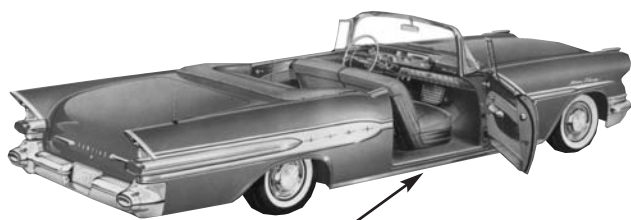

PF680

PF680 1957 Rocker Panel Moldings, Stainless Steel
- Bonneville and Star Chief (APE) \$189.00/pr.
See PF714 & PF714A for clips.



PF680A

PF680A 1957 Rocker Panel Molding, Stainless Steel
- Safari (APE) 189.00/pr.

Comments: Excellent.

Many customers have used these Safari moldings to dress up their Chieftain bodies. Although not original equipment they look excellent.

See PF714 and PF714A for clips.

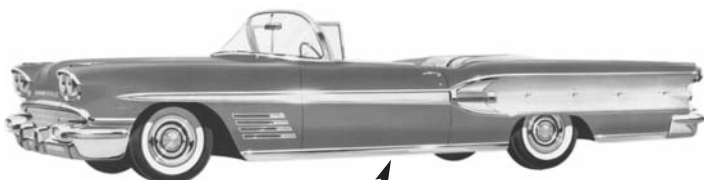

PF681

PF681 1958 Rocker Panel Moldings, Stainless Steel
- Bonneville (APE) 214.00/pr.

Comments: Excellent.

See PF715 and PF715A for clips.



PF695 & PF696

PF695 1969 Rocker Panel Moldings, Stainless Steel
- GP (APE)..... 145.00/pr.

PF696 1970-72 Rocker Panel Moldings
(Aluminum) - GP (APE)..... 135.00/pr.

Note: Both stainless steel and anodized aluminum rocker panel moldings were used on 1969-72 GPs. Please be sure to check your original molding material.

See PF745 & PF745B for clips.

Add \$12.00 oversize fee to standard shipping for all rocker panel moldings.



PF714

PF714 1957 Rocker Panel Molding Clip (RE) \$3.50/ea.

PF714A 1957 Rocker Panel Molding Clip Set
- 14 pcs. (RE) 38.00/set

Quality: Excellent

PF714B 1957 Front Fender Rocker Panel Molding
Clip With Stud (RE)..... 3.50/ea.

PF715 1958 Rocker Panel Molding Clip
(AP-GM)..... Disc.

PF715A 1958 Rocker Panel Molding Clip Set
- 12 clips (AP-GM) Disc.

PF715 and PF715A are plastic GM aftermarket clips. Comments:



PF714B



PF720

PF720 1962-64 Rocker Panel Molding Clip (Exc. '64
Bonneville) (1st Design) (RE) 3.00/ea.

PF720A 1962-64 Rocker Panel Molding Clip Set
(Exc. '64 Bonneville) (12 Clips)
(1st Design) (RE) 32.00/set



PF721

PF721 1962-64 Rocker Panel Molding Clip (Exc. '64
Bonneville) (2nd Design) (RE) 2.50/ea.

PF721A 1962-64 Rocker Panel Molding Clip Set
(Exc. '64 Bonneville) (12 Clips)
(2nd Design) (RE) 20.00/set

Note: Since two styles of rocker panel molding clips were used in 1962-64, be sure to identify your needs using the clip diagrams provided.

PF743 1968 Rocker Panel Molding Clip (RE) Disc.

PF745 1969-72 Rocker Panel Molding Clip
- GP (RE) 4.00/ea.

Note: These clips mount on the face of the rocker panel and are similar in design to PF721.

PF745A 1968-72 Rocker Panel Molding Clip
- Lower (RE) 2.50/ea.

These are the 8 1/2" long clips that bolt under the rocker panel and hold the bottom of the molding.

PF745B 1969-72 Rocker Panel Molding Clip Set
- GP (RE) 22.00/set

DOOR COMPONENTS

ROCKER PANELS



Note: These rocker panels are the steel panels painted body color under the doors. Many people confuse these with the stainless steel or aluminum rocker panel moldings.

PF751L	1955-57 Inner Rocker Panel, LH - 2 Dr. (RE).....	\$65.00/ea.
PF751R	1955-57 Inner Rocker Panel, RH - 2 Dr. (RE)	65.00/ea.
PF752L	1955-57 Outer Rocker Panel, LH - 2 Dr. (RE).....	109.00/ea.
PF752R	1955-57 Outer Rocker Panel, RH - 2 Dr. (RE)	109.00/ea.
PF753L	1955 Outer Rocker Panel, LH - 4 Dr. (RP)	55.00/ea.
PF753R	1955 Outer Rocker Panel, RH - 4 Dr. (RP)	55.00/ea.
PF754L	1956-57 Outer Rocker Panel, LH - 4 Dr. Sedan/SW (RE).....	135.00/ea.
PF754R	1956-57 Outer Rocker Panel, RH - 4 Dr. Sedan & SW (RE).....	135.00/ea.
PF756L	1958 Inner Rocker Panel, LH - 2 Dr. (RE).....	109.00/ea.
PF756R	1958 Inner Rocker Panel, RH - 2 Dr. (RE)	109.00/ea.
PF757L	1958 Outer Rocker Panel, LH - 2 Dr. (RE).....	155.00/ea.
PF757R	1958 Outer Rocker Panel, RH - 2 Dr. (RE)	155.00/ea.
PF758L	1958 Outer Rocker Panel, LH - 4 Dr. (RE).....	30.00/ea.
PF758R	1958 Outer Rocker Panel, RH - 4 Dr. (RE)	30.00/ea.
PF760L	1959-60 Outer Rocker Panel, LH - 2 Dr. (RP)	69.00/ea.
PF760R	1959-60 Outer Rocker Panel, RH - 2 Dr. (RP)	69.00/ea.
PF761L	1959-60 Outer Rocker Panel, LH - 4 Dr. (RE).....	Disc.
PF761R	1959-60 Outer Rocker Panel, RH - 4 Dr. (RE)	Disc.
PF765L	1965-68 Outer Rocker Panel, LH - 2 Dr. (RE).....	43.00/ea.
PF765R	1965-68 Outer Rocker Panel, RH - 2 Dr. (RE)	43.00/ea.
PF766L	1965-68 Outer Rocker Panel, LH - 4 Dr. (RE).....	36.00/ea.
PF766R	1965-68 Outer Rocker Panel, RH - 4 Dr. (RE)	36.00/ea.
PF770L	1969-72 Rocker Panel, LH - GP (RE).....	109.00/ea.
PF770R	1969-72 Rocker Panel, RH - GP (RE).....	109.00/ea.

Add \$20.00 oversize fee to standard shipping for rocker panels.



DOOR SKINS

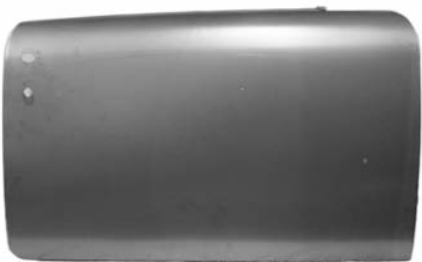

PF802R

PF802L	1955-57 Door Skin, LH - 2 Dr. HT & CVT (RE) ...	239.00/ea.
PF802R	1955-57 Door Skin, RH - 2 Dr. HT & CVT (RE)..	239.00/ea.
PF802AL	1955-57 Door Skin, LH - 2 Dr. Sedan (RE).....	239.00/ea.
PF802AR	1955-57 Door Skin, RH - 2 Dr. Sedan (RE).....	239.00/ea.

Note: PF802AL and PF802AR do not include the window frame.

Add \$25.00 oversize fee to standard shipping for Door Skins.



PF802B

PF802B	1955-57 Door Handle Reinforcements - All (RE)	\$43.00/pr.
---------------	---	-------------

PF802B spot welds inside the door skin, providing extra support for outside door handles. There is no need to work with rusty old parts when installing new door skins.

LOWER DOOR SKINS & PANELS

PF802GL	1955-57 Lower Door Skin Outer-All 2 Dr. - LH (RE)	73.00/ea.
PF802GR	1955-57 Lower Door Skin Outer-All 2 Dr. - RH (RE)	73.00/ea.

Add \$12.00 oversize fee to standard shipping for lower door skins.



PF802RL

PF802RL	1955-57 Inner Door Bottom Patch, LH - 2 Dr. HT & CVT (RE)	140.00/ea.
PF802RR	1955-57 Inner Door Bottom Patch, RH - 2 Dr. HT & CVT (RE)	140.00/ea.
PF802SL	1955-57 Inner Door Bottom Patch, LH - 2 Dr. Sedan & Safari(RE)	Disc.
PF802SR	1955-57 Inner Door Bottom Patch, RH - 2 Dr. Sedan & Safari(RE)	Disc.



PF808L

PF808L	1961-64 Door Bottom Repair Panel, LH - All 2 Dr(RE).....	239.00/ea.
PF808R	1961-64 Door Bottom Repair Panel, RH - All 2 Dr.(RE)	239.00/ea.

Add \$12.00 oversize fee to standard shipping for door bottom repair panels.



DOOR COMPONENTS

WINDSHIELD & REAR WINDOW RELATED

WINDSHIELD REVEAL MOLDINGS

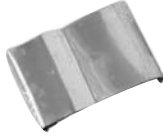
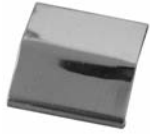

- | | | | |
|--|--------|--|------------|
| | PG170 | 1955-57 Upper Front Windshield Reveal Escutcheon -All exc. CVT (RE)..... | \$9.00/ea. |
| | PG170B | 1955-57 Lower Front Windshield Reveal Escutcheon (RE) | 9.00/ea. |
| | PG172 | 1955-57 Outer Corner Moldings -CVT, Pair (RE). | 399.00/pr. |



- | | | | |
|--|--------|--|------------|
| | PG220 | 1969-72 Upper Windshield Reveal Molding - GP (GM)..... | Disc. |
| | PG221L | 1969-72 Side Windshield Reveal Molding, LH - GP (GM) | Disc. |
| | PG221R | 1969-72 Side Windshield Reveal Molding, RH - GP (GM) | 115.00/ea. |



- | | | | |
|--|-------|--|-----------|
| | PG222 | 1969-72 Windshield Reveal Set 3 Piece Set - GP (RE)..... | 99.00/set |
|--|-------|--|-----------|
- Add \$8.50 oversize fee to standard shipping for PG222.**



- | | | | |
|--|-------|--|----------|
| | PG223 | 1969-72 Lower Windshield Molding Screw Set, 7pcs. - GP (RE)..... | 3.00/set |
|--|-------|--|----------|

These are the unique screws used in retaining the wide lower windshield molding. These are commonly replaced with generic screws.



- | | | |
|--|--------|---|
| | PG223D | 1969-72 Lower Windshield Molding -GP (RE). \$149.00/ea. |
|--|--------|---|
- Add \$12.00 oversize fee to standard shipping for PG223D.**



REAR WINDOW REVEAL MOLDINGS

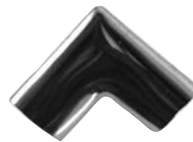

- | | | | |
|--|--------|--|-----------|
| | PG238 | 1955-57 Upper Rear Window Reveal Corner Molding w/Clips - 2 Dr. HT (RE)..... | 16.00/pr. |
| | PG238B | 1955-57 Upper Rear Window Reveal Corner Molding w/Clips - Sedan (RE)..... | 16.00/pr. |
| | PG239 | 1955-57 Lower Rear Window Reveal Escutcheon - 2Dr. HT & Sedan (RE)..... | 9.00/ea. |
| | PG239B | 1956-57 Lower Rear Window Reveal Escutcheon - 4Dr. HT (RE) | 9.00/ea. |
| | PG251L | 1969-70 Lower Rear Window Reveal Molding, LH - GP (GM)..... | Disc. |

FRONT DRIP RAIL MOLDINGS

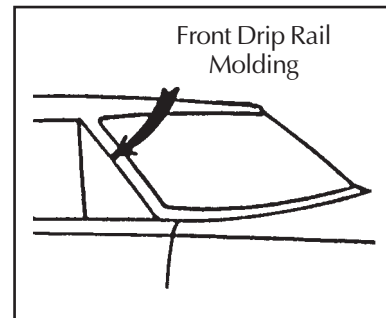

- | | | | |
|--|-------|---|-----------|
| | PG280 | 1969-72 Front Drip Rail Molding - GP (RE) | 32.00/pr. |
| | PG281 | 1969-72 Front Drip Rail Molding Escutcheon - GP (RE)..... | 10.00/pr. |

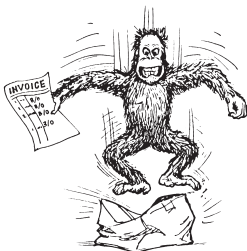

DON'T BACKORDERS MAKE YOU HOPPING MAD?

Needless backorders are aggravating, costly, and time-consuming. Each year we've become more efficient reaching an unbelievably low backorder rate. Last year 94.9% of all invoices were shipped without backorders and 98.7% of all items ordered were shipped without backorders.

If you want your parts NOW (and we mean ALL your parts) or have questions, call:

(800) 421-2637 (AMES).

WINDSHIELD & REAR WINDOW

REVEAL MOLDING CLIPS



PG289AB

PG289AB 1955-57 Front Lower Reveal Molding Clip Set (RE) \$10.00/set



PG289AF

PG289AF 1955-57 Front Windshield Reveal Corner Molding Clips (RE) 10.00/pr.

PG289AM 1955-58 Rear Reveal Molding Clip Set w/o Corner Molding Clips, 15 pcs. (RE). 4.50/set



PG289P

PG289AP 1955-57 Rear Reveal Corner Molding Clips (RE). Disc.
PG289P 1963-64 Front Lower Reveal Clip Set - All FS (RE) 13.00/set

This set includes 8 center clips and 1 pair side clips for the front lower reveal moldings.



PG289S

PG289S 1961-64 Rear Window Reveal Clip - All Catalina and 4 Dr. Sedan Star Chief (RE) 1.50/ea.

We have found this to fit other cars also; refer to photo for possible fit.



PG290

PG290 1965-68 Front Reveal Molding Clip 3/4"W x 5/8"H (AP)50/ea.



PG290B

PG290B 1965-68 Rear Reveal Molding Clip 1" W x 7/8"H (AP)50/ea.



PG290F

PG290F 1969-72 Front and Rear Reveal Molding Clip - GP 1 7/16"W x 13/16"H (AP)50/ea.

PG290F 1969-76 Front and Rear Reveal Molding Clip - FS 1 7/16"W x 13/16"H (AP)50/ea.

Note: Because different assembly plants used different numbers of clips, you should determine how many you need prior to placing your order.



PG291

PG291 1960-77 Screw In Replacement Clip Stud (AP) ... \$4.50/box

PG291 replaces broken or missing nail head studs used in securing reveal molding clips to the body. These are a must when replacing windshield or rear window panels. 100 pieces per box.



PG291H

PG291H 1955-77 Window Reveal Molding Removal Tool (AP)..... 15.00/ea.



PG293

PG293 1965-76 Window Reveal Clip Installation Tool (AP)..... 20.00/ea.

INSTALLATION KITS

PG300 1965-77 Windshield Installation Kit - All (AP) 11.00/ea.

PG301 1965-77 Rear Window Installation Kit - All (AP) 11.00/ea.

These kits include enough sealant rubber for the installation of either the front or rear window.

PG303 Window Weld Resealant, Tube..... 16.00/ea.
 Fits 1/10th gallon cartridge gun.

WINDSHIELD CHANNELS



PK409

Note: These are the heavy rubber channels that hold the windshield in place.

PG400 1955-57 Windshield Glass Channel - Exc. CVT (RE) 42.00/ea.

PG401 1955-57 Windshield Glass Channel - CVT (RE) 42.00/ea.

PG402 1958 Windshield Glass Channel - 2 Dr. HT & CVT Bonneville (RE) 42.00/ea.

PG403 1958 Windshield Glass Channel - All Star Chief (RE) 87.00/ea.

PG404 1959-60 Windshield Glass Channel - All HT & CVT (RE) 51.00/ea.

PG405 1959-60 Windshield Glass Channel - All Sedan & SW(RE) 51.00/ea.

PG406 1961-62 Windshield Glass Channel - Exc. CVT & 1962 2 Dr. HT (RE) 39.00/ea.

PG407 1961-62 Windshield Glass Channel - CVT (RE) 39.00/ea.

PG408 1962 Windshield Glass Channel - 2 Dr. HT (RE) 39.00/ea.

PG409 1963-64 Windshield Glass Channel - 2 Dr. HT & CVT Exc. GP (RE) 51.00/ea.

PG409A 1963-64 Windshield Glass Channel - GP (RE) 39.00/ea.

PG410 1963-64 Windshield Glass Channel - Sedan and SW (RE) 51.00/ea.

PG411 1963-64 Windshield Glass Channel - 4 Dr. HT (RE) 39.00/ea.

WINDSHIELD & REAR WINDOW

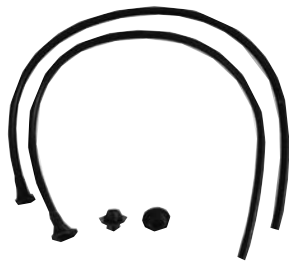

PG416

PG415 1955 Windshield Gutter Inner Cowl Panel Drain (RE)..... \$9.00/pr.

PG416 1956-57 Windshield Gutter Inner Cowl Panel Drain (RE)..... 10.00/pr.

Customers have reported that PG416 works equally well on '59-'60 Pontiacs.

PG417 1955-64 Outer Corner Cowl Plug (RE)..... 1.50/ea.

PG418 1963-64 Side Cowl Panel Plug (RE)..... 3.00/ea.

REAR GLASS CHANNELS

Note: These are the heavy rubber channels that hold the rear window in place.

PG420 1955 Rear Glass Channel - Sedan (RE)..... 42.00/ea.

PG421 1955-57 Rear Glass Channel - 2 Dr. HT (RE) 42.00/ea.

PG422 1956-57 Rear Glass Channel - Sedan (RE)..... 51.00/ea.

PG423 1956-57 Rear Glass Channel - 4 Dr. HT (RE) 47.00/ea.

PG424 1955-57 Rear Glass Channel - Safari (RE)..... 39.00/ea.

PG425 1958 Rear Glass Channel - Bonneville (RE) ... 42.00/ea.

PG426 1958 Rear Glass Channel - All Exc. Bonneville (RE) 90.00/ea.

PG427 1959-60 Rear Glass Channel - Sedan w/o Inside Garnish Molding (RE)..... 119.00/ea.

PG428 1959-60 Rear Glass Channel - Sedan w/Inside Garnish Molding (RE)..... 55.00/ea.

PG428A 1959-60 Rear Glass Channel - 2 Dr. HT w/o Inside Garnish Molding (RE)..... 120.00/ea.

PG429 1959-60 Rear Glass Channel - 2 Dr. HT w/Inside Garnish Molding (RE)..... 99.00/ea.

PG429B 1959-60 Rear Glass Channel - 4 Dr. HT (RE) 173.00/ea.

PG430 1961 Rear Glass Channel - 2 Dr.HT (RE) 47.00/ea.

PG431 1961 Rear Glass Channel - Sedan (RE)..... 120.00/ea.

PG432 1961-62 Rear Glass Channel - 4 Dr. HT (RE) 122.00/ea.

PG433 1962-64 Rear Glass Channel - 2 Dr. HT exc. '63-'64 GP (RE)..... 47.00/ea.

PG433A 1963-64 Rear Glass Channel - GP (RE)..... 57.00/ea.

PG434 1962-64 Rear Glass Channel - Sedan (RE)..... 47.00/ea.

PG435 1963-64 Rear Glass Channel - 4 Dr. HT (RE) 47.00/ea.



PG440

PG440 1955-59 Rear Glass Channel Drain (RE)..... 10.00/pr.

WINDSHIELD WIPER ESCUTCHEON COMPONENTS



PG500

PG500 1955-56 Windshield Wiper Escutcheons w/ Nuts (RE)..... \$49.00/kit



PG500A

PG500A 1955-56 & '58 Wiper Escutcheon Nut Removal Tool (AP)..... 10.00/ea.

Note: This tool is used in conjunction with a screwdriver to remove that inaccessible escutcheon nut.



PG500AD

PG500AD 1955-56 & '58 Wiper Escutcheon Nuts (RE)..... Inquire

WINDSHIELD WIPER ARMS & LINK ASSEMBLIES



PG540L

PG540L 1955-57 Wiper Arm, Bayonet Style, LH (RE)..... 21.00/ea.

PG540R 1955-57 Wiper Arm, Bayonet Style, RH (RE) 21.00/ea.

PG542L 1959-60 Wiper Arm, All Trico w/ Overlap, 16 1/4" Overall Length, LH (RE)..... 21.00/ea.

PG542R 1959-60 Wiper Arm, All Trico w/ Overlap, 16 1/4" Overall Length, RH (RE)..... 21.00/ea.



PG550

PG550 1969-72 Windshield Wiper Arm and Blade Set - GP (RE)..... 99.00/set

Contains both blades and both arms.

Quality: Very good with correct satin finish.



PG574

PG574 1955-57 Wiper Pivot Rivets (RE) 2.00/pr.

Note: These rivets hold the arm to the splined shaft. One set per car.

WINDSHIELD & REAR WINDOW

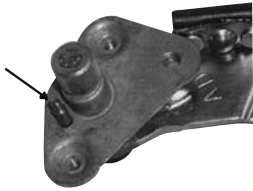

PG579

PG579 1969-72 Driver's Side Wiper Arm Pin Repair Kit - GP (RE) \$10.00/kit

This repairs the often broken or missing articulating pin for the driver's side wiper arm rod. Installation tool and instructions included.

WINDSHIELD WIPER BLADES



PG580D

PG580D 1955-57 Wiper Blade, Bayonet Style (RP)..... 21.00/ea.

These are polished stainless steel blades without any Trico markings. Excellent replacement.



PG580J

- PG580E** 1958 Windshield Wiper Blade (RP) 10.00/ea.
- PG580J** 1959-64 Trico Wiper Blade w/o Overlap Blades, LH or RH - Exc. GP (AP)..... 15.00/ea.
- PG580L** 1959-64 Trico Wiper Blade w/Overlap Blades, LH or RH - Exc. GP (AP)..... 20.00/ea.
- PG580J** 1967-68 Trico Wiper Blade, LH or RH - GP (AP). 15.00/ea.
- PG580N** 1965-66 Trico Wiper Blade, LH or RH- Exc. GP (AP) Inquire
- PG580L** 1967-77 Trico Wiper Blade, LH or RH- Exc. GP (AP) 20.00/ea.
- PG580P** 1969-77 Trico Wiper Blade, LH or RH - GP (AP). 15.00/ea.

These blades are almost exactly like originals, although they do not have the "Trico" trademark stamping.

WINDSHIELD WIPER MOTORS & COMPONENTS

Wiper motors require a \$35.00 refundable core charge. Core must be rebuildable and returned in the original box for credit.



PG620

- PG619** 1963-64 2 Speed Wiper Motor - FS (RP)..... 275.00/ea.
- PG620** 1968-72 Wiper Motor w/ Pump - All FS (RP)..... 88.00/ea.
- PG621A** 1969-77 Wiper Motor w/ Pump - All GP (RP).... 88.00/ea.

PG620 & PG621A are replacement motors that may differ in appearance from original but function fine.



PG630

PG630 Electric Wiper Motor Grommets w/ Screws (RE) \$11.00/set

Note: This set includes three grommets and three attaching bolts.

See the Engine Compartment section for windshield washer components.

PG640 1963-77 Windshield Wiper Motor Mounting Bolts, Set of 3 (RE)..... 4.00/set

PG655 1959-62 Windshield Wiper Motor Crank Cap (2 speed wiper only) (RE) 19.00/ea.



PG656

PG656 1963-64 Wiper Motor Transmission Clip (RE)..... 3.00/ea.

PG656 secures the wiper transmission to the wiper motor arm.

WIPER SWITCHES



Not an exact photo

- PG660** 1959-62 Windshield Wiper Switch, Single Speed(RE) 29.00/ea.
- PG661** 1963 Windshield Wiper Switch, Single Speed(RE) 29.00/ea.
- PG662** 1964 Windshield Wiper Switch, Single Speed(RE) 29.00/ea.
- PG663** 1965 Windshield Wiper Switch, Single Speed(RE) 29.00/ea.
- PG665** 1967-68 Windshield Wiper Switch..... 65.00/ea.
- PG669** 1968 Wiper Switch Knob 19.00/ea.

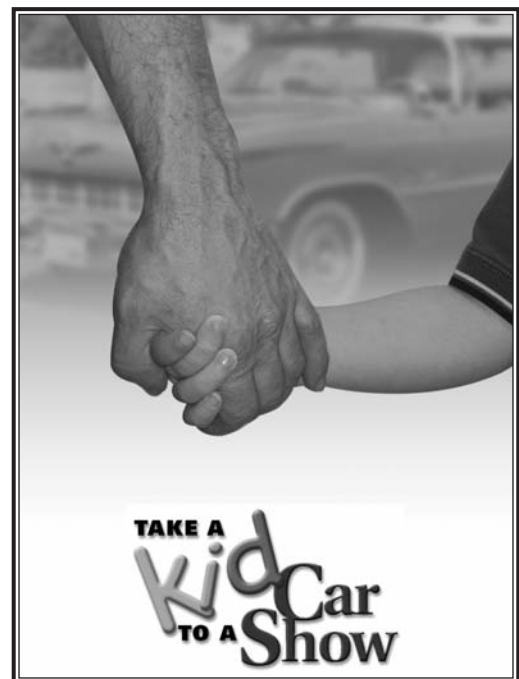

www.takeakidtoacarshow.com

CONVERTIBLE TOPS

CONVERTIBLE TOP BOOTS



PH101	1955-57	Convertible Top Boot (RE)	\$129.00/ea.
PH102	1958	Convertible Top Boot (RE)	Inquire
PH103	1959-60	Convertible Top Boot (RE)	149.00/ea.
PH104	1961-64	Convertible Top Boot (RE)	149.00/ea.
PH105	1965-68	Convertible Top Boot (RE)	149.00/ea.
PH105D	1969-70	Convertible Top Boot (RE)	139.00/ea.
PH105F	1971	Convertible Top Boot (RE)	139.00/ea.
PH105G	1972-75	Convertible Top Boot (RE)	139.00/ea.

Boot material is die-cut and stitched like original. Vinyl is correct and comes in a variety of colors—please carefully note if your car needs a white or parchment (off-white) boot. In trying to match parchment interiors several customers have mistakenly ordered a white boot.

Boot storage bag (PH106) comes with top boot.

CONVERTIBLE TOP BOOT COMPONENTS



	PH107		PH107C	
PH106	1955-75	Convertible Top Boot Bag (RE)	4.50/ea.

This is an exact reproduction of GM's discontinued black 6 mil boot bag.

PH107	1955-76	Top Boot Snap Set (RP)	3.50/set
--------------	---------	------------------------	-------	----------

PH107 snaps are replacements with coarse tapping threads. Use if original welded nut threads are no longer useable.

PH107C	1955-76	Top Boot Snap Set (RE)	5.00/set
---------------	---------	------------------------	-------	----------

PH107C snaps are original style snaps with fine thread. Use if original welded nuts are still intact.



PH109

PH109	1955-70	Convertible Top Boot Retainer Channel (RE)	99.00/ea.
--------------	---------	--	-------	-----------

This channel is used on the back of the rear seat. The top boot slides into this channel. Measures 3/4" x 42 1/4".



PH109D

PH109D	1955-57	Convertible Top Well Molding Snaps (RE)	61.00/set.
---------------	---------	---	-------	------------

CONVERTIBLE TOP KITS

PH120	1955-57	Convertible Top Kit w/Plastic Window and Pads (RE)	\$359.00/ea.
PH121	1958	Convertible Top Kit w/Plastic Window and Pads (RE)	339.00/ea.
PH122	1959-60	Convertible Top Kit w/Plastic Window and Pads (RE)	299.00/ea.
PH123	1961	Convertible Top Kit w/Plastic Window and Pads (RE)	249.00/ea.
PH124	1962-64	Convertible Top Kit w/Plastic Window and Pads (RE)	269.00/ea.
PH125	1965-66	Convertible Top Kit w/Glass Window and Pads (RE)	349.00/ea.
PH126	1967-68	Convertible Top Kit w/Glass Window and Pads (RE)	349.00/ea.
PH127	1969-70	Convertible Top Kit w/Glass Window and Pads (RE)	349.00/ea.
PH128	1971-75	Convertible Top Kit w/Glass Window and Pads (RE)	349.00/ea.

Note: Tops are quality stitched using only top of the line 38-ounce vinyl. These kits come complete with items necessary to replace your top (pads, top, and window). Top components have a two-year warranty on materials and workmanship. We recommend professional installation of convertible tops. For colors other than black or white please request samples.

Add \$12.00 oversize fee to standard shipping when ordering 1965-75 tops with glass rear windows.

REAR WINDOW KITS



PH135	1955-57	Plastic Rear Window w/Vinyl (RE)	99.00/ea.
PH136	1958	Plastic Rear Window w/Vinyl (RE)	99.00/ea.
PH137	1959-60	Plastic Rear Window w/Vinyl (RE)	99.00/ea.
PH138	1961	Plastic Rear Window w/Vinyl (RE)	99.00/ea.
PH139	1962-64	Plastic Rear Window w/Vinyl (RE)	99.00/ea.
PH140	1965-66	Glass Rear Window w/Vinyl (RE)	179.00/ea.
PH141	1967-68	Glass Rear Window w/Vinyl (RE)	179.00/ea.
PH142	1969-70	Glass Rear Window w/Vinyl (RE)	179.00/ea.
PH143	1971-75	Glass Rear Window w/Vinyl (RE)	189.00/ea.

Note: All rear windows will fit original tops.

Add \$12.00 oversize fee to standard shipping when ordering PH140-PH143.



CONVERTIBLE TOP PADS

PH150	1955-75	Convertible Top Pads (RE)	30.00/pr.
--------------	---------	---------------------------	-------	-----------

CONVERTIBLE TOP WELLS

PH161	1955-56	Convertible Top Well (RE)	59.00/ea.
PH164	1959-60	Convertible Top Well (RE)	56.00/ea.
PH165	1961-64	Convertible Top Well (RE)	57.00/ea.
PH166	1965-68	Convertible Top Well (RE)	57.00/ea.
PH167	1969-70	Convertible Top Well (RE)	62.00/ea.
PH168	1971-75	Convertible Top Well (RE)	72.00/ea.

Wells are not made from original material, but fit and look fine.

Comments: Excellent.

CONVERTIBLE TOP

TACK STRIPS



PH180D

PH180D 1955-57 Convertible Top Rear Tack Strip w/ Bow (3 pcs) (RE)..... \$269.00/set

Includes mounting hardware.

Add \$12.00 oversize fee to standard shipping for PH180D.



PH180K 1955-75 Convertible Top Tacking Strip, Front, 1/8" x 5/8" (RE)..... 2.00/ft.

This 5/8" tacking strip is thinner than original GM. Using two strips results in approximately the correct thickness.

PH180M 1955-75 Convertible Top Tacking Strip, Rear, 3/8" x 1/2" (RE)..... 2.00/ft.

Note: PH180K and PH180M are plastic strips that replace your original cardboard pieces. Most cars use 5 to 6 feet at each location.

PH180PBK 1968-72 Convertible Header Vinyl, Black (RE) ... 12.00/ea.



PH182B

PH182B 1955-57 Convertible Upper Windshield Molding - Chrome (RE) 379.00/ea.

Add \$12.00 oversize fee to standard shipping for PH182B.



PH185 1955-57 Convertible Header Molding (RE) 529.00/pr.

CONVERTIBLE REAR MOLDING CLIPS



PH190

PH187 1955-57 Convertible Rear Molding Clips (RE) 35.00/set

PH190 1961-64 Convertible Rear Molding Clips (RE) 4.00/ea.

PH190B 1965-66 Convertible Rear Molding Clips (RE) Inquire

PH190D 1967-68 Convertible Rear Molding Clips (RE) 4.00/ea.

These are the clips that hold the molding secure around the rear of the top well. (The top boot snaps to this molding.)

CONVERTIBLE PINCH RAIL PADS



PH192B

PH192B 1955-57 Pinch Rail Pad kit (RE) 17.00/kit
Note: 18 pads per kit.

PH192D 1958-64 Pinch Rail Pad kit (RE)..... 22.00/kit
Note: 24 pads per kit

PH192B and PH192D are located in the trunk area between the rear pinch rail and body.

CONVERTIBLE LATCHING & TOP FRAME COMPONENTS



PH199

PH199 1955-57 Convertible Top Hardware and Bolt Kit (RE)..... \$169.00/set

PH199B 1959-60 Convertible Top Hardware and Bolt Kit (RE)..... 169.00/set

These kits contain hardware to replace and install a convertible top frame and top cylinders. Comes complete with instructions and pictures.

Comments: Excellent kit.



PH199D

PH199D 1955-57 Convertible Top Front Guide Pin - Stainless Steel (RE) 7.50/ea.



PH199G

PH199G 1955-57 Convertible Top Side Rail Adjuster Bolt (RE)..... 7.00/ea.

This is the square-headed bolt above the door glass on the top side rail.



PH201

PH200 1955-57 Convertible Striker Plates - Chrome (RE) Disc.

PH200A 1955-57 Convertible Striker Plates Screw Kit - Stainless Steel - w/ Star Washers (RE) .. 2.50/set



PH200D

PH200D 1955-57 Latch Plates (RE) 22.00/pr.

These are the latch plates that go around the latch handles. They come w/ mounting hardware.

PH201 1955-58 Convertible Sunvisor Hooks (RE)..... Disc.

CONVERTIBLE TOP

TOP HANDLES & LATCHES



PH202

PH202 1955-60 Convertible Top Handles (RE) \$99.00/pr.

Note: PH200 through PH202 are excellent quality reproductions.

PH202A 1955-60 Convertible Top Handle Mounting Screws, Stainless Steel (RE)... 2.50/pr.



PH202CL

PH202CR

PH202CL 1955-60 Convertible Top Latch w/Handle, LH (RE) 50.00/ea.

PH202CR 1955-60 Convertible Top Latch w/Handle, RH (RE) 50.00/ea.



PH203S

PH203S 1961-64 Convertible Top Bolt Kit (RE) 159.00/kit

This kit contains enough hardware to assemble the top frame and detailed instructions.



PH204AL



PH204BB

PH204 1961-64 Convertible Top Handles (RE) 49.00/pr.

PH204AL 1961-64 Convertible Top Latch, LH (RE)..... 169.00/ea.

PH204AR 1961-64 Convertible Top Latch, RH (RE) 169.00/ea.

PH204BB 1961-64 Convertible Top Latch Bushings w/ Snap Rings (RE)..... 18.00/pr.

These are the bushes that the convertible top latch pin slides into.



PH208

PH208 1965-70 Convertible Latch Hook Knuckles w/Pins (RE)..... 29.00/pr.

Latch knuckles often break around the pin. This new reproduction is stronger and uses a slightly larger pin. In order to use these knuckles the top bracket must be enlarged about .009 inch using a 15/64 drill.



PH210

PH212

PH214

PH210 1965-75 Front Roof Rail Hook (RE) \$5.50/ea.

PH212 1965-70 Front Roof Rail Guide Pin (RE) 6.00/ea.

Note: This is the pin that guides the convertible top frame into the windshield header.

PH214 1955-75 Convertible "Wire-on" Caps (AP) 2.00/ea.



PH230L

PH230L 1971-75 Front Roof Rail Lock, LH (RE) 139.00/ea.

PH230R 1971-75 Front Roof Rail Lock, RH (RE) 139.00/ea.

Note: PH230R and PH230L are the mechanisms which hold the top frame to the windshield header.

CONVERTIBLE TOP MAINTENANCE



PH238B

PH238D

PH238F

PH238H

PH238B "Koala" Convertible Top Cleaner (32 oz.) (AP) 14.00/ea.

PH238D "Koala - Kamikaze" Yearly Cleaner (32 oz.) (AP) 14.00/ea.

PH238F "Koala" Convertible Top Sealer (16 oz.) (AP) 16.00/ea.

Note: PH238F must be used after cleaning top with PH238D.

PH238H "Koala" Plastic Window Polish (2 oz.) (AP) 12.00/ea.

CONVERTIBLE CYLINDERS & HARDWARE



PH245

PH245 1955-57 Convertible Top Cylinder, LH or RH (RE) 159.00/ea.

PH246 1958 Convertible Top Cylinder, LH or RH (RE)..... 159.00/ea.

PH247 1959-60 Convertible Top Cylinder, LH or RH (RE) 159.00/ea.

PH248 1961 Convertible Top Cylinder, LH or RH (RE) 159.00/ea.

PH249 1962 Convertible Top Cylinder, LH or RH (RE) 159.00/ea.

PH250 1963-64 Convertible Top Cylinder, LH or RH (RE) 159.00/ea.

PH251 1965-70 Convertible Top Cylinder, LH or RH (RE) 159.00/ea.

Note: These top cylinders are not rebuilt units, but are newly manufactured. Appearance may differ slightly from original.

Comments: The finest available.

CONVERTIBLE TOP



PH255

PH255 1955-61 Convertible Top Cylinder Support Spacers (RE) \$3.50/pr.

Note: Requires 2 pairs per car.

PH256 1955-57 Convertible Top Cylinder Braces (RE) ... 18.00/pr.

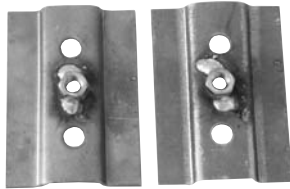

PH256



PH256L

PH256L 1955-57 Convertible Top Cylinder Bracket w/ Hardware, LH (RE)..... 70.00/ea.

PH256R 1955-57 Convertible Top Cylinder Bracket w/ Hardware, RH (RE) 70.00/ea.



PH256X

PH256X 1955-57 Convertible Top Cylinder Mounting Kit (RE)..... 14.00/kit

Requires one kit per car.

PH257C 1963-70 Convertible Top Cylinder Nylon Bushing (RE) 2.00/ea.

These are the pivot bushings in the top cylinder. 2 required per cylinder.



PH257C

CONVERTIBLE TOP PUMPS & MOTORS

Note 1: These pump-motor assemblies are meant as replacements. The existing reservoir may be swapped. Hoses need no alteration.

Note 2: As with any top hydraulic system, do not fill reservoir more than 75% of capacity.



PH259

PH259 1955-57 Convertible Top Pump and Motor Cover (RP) 99.00/ea.

PH260 1955-63 Convertible Top Pump and Motor (RP) . 279.00/ea.

PH261 1964 Convertible Top Pump and Motor (RP) . 265.00/ea.



PH263

PH263 1965-70 Convertible Top Pump and Motor(RP).. 279.00/ea.

PH264 1971-75 Actuator Motor (RE)..... 245.00/ea.

PH264K 1971-75 Actuator Motor Relay (GM) Disc.

CONVERTIBLE TOP CABLES & HOSES



PH265L

PH265L 1971-75 Actuator Cable, LH - FS (GM) \$69.00/ea.

PH265R 1971-75 Actuator Cable, RH - FS (GM) 69.00/ea.

PH267 1955-70 Convertible Top Pump Motor Grommet (RE)..... 2.50/ea.

PH270 1955-61 Convertible Top Hose Kit (RP) 109.00/kit

PH271 1962-70 Convertible Top Hose Kit (RP) 109.00/kit

Note: These hoses will finish your convertible top rebuild. Kit comes complete with hose and fittings. Since these are universal kits, excess hose may be coiled to complete the installation.



PH267



PH271



PH271D

PH271D 1955-66 Convertible Top Hose Retaining Clip (screw-on) (RE)..... 3.50/ea.

PH271DB 1955-66 Convertible Top Hose Retaining Clip (push-in) (RE) 6.50/ea.

Note: These clips hold the hose in place for clean routing. Four are required on most cars.

PH275 Convertible Top Bleeder System..... 18.00/kit

Note: This kit comes complete with filler plug adapter, hose and most importantly, complete instructions. Bleeder system was copied from the GM Fisher Body Manual.



PH271DB

CONVERTIBLE TOP SWITCHES



PH275J

PH275F 1958 Convertible Top Switch (RP) 79.00/ea.

Note: This is a replacement switch that customers have successfully used without modification.

PH275J 1966 Convertible Top Switch (RE)..... 79.00/ea.



PH275M

PH275M 1968 Convertible Top Switch (RE)..... 89.00/ea.

PH275M is made in a 2-piece design for ease of installation & will need to be spliced together. Includes bezel & knob.



PH276

PH276 1969-70 Convertible Top Switch (RP) 69.00/ea.

Note: The bezel on PH276 is made from stainless, not die-cast chrome like the original.

CONVERTIBLE TOP HOLD-DOWN CABLES



PH290

PH289	1961-64 Convertible Top Hold-Down Cables (RE)	\$49.00/pr.
PH290	1965-70 Convertible Top Hold-Down Cables (RE)	33.00/pr.
PH291L	1971-75 Convertible Top Hold-Down Cable, LH (GM)	Disc.
PH291R	1971-75 Convertible Top Hold-Down Cable, RH (GM)	Disc.

CONVERTIBLE TOP WEATHERSTRIP



PH300	1955-57 Convertible Top Weatherstrip Set (RE) ..	250.00/set
PH301	1958 Convertible Top Weatherstrip Set (RE) ..	299.00/set
PH302	1959-60 Convertible Top Weatherstrip Set (RE) ..	229.00/set
PH303	1961-64 Convertible Top Weatherstrip Set (RE) ..	219.00/set
PH304	1965-66 Convertible Top Weatherstrip Set (RE) ..	229.00/set
PH305	1967-70 Convertible Top Weatherstrip Set (RE) ..	282.00/set
PH306	1971-75 Convertible Top Weatherstrip Set (RE) ..	229.00/set

The above top weatherstrip sets include all weatherstrips needed for your convertible top. All pieces have been duplicated from originals including the steel inserts.

Note: Pillar post weatherstrips are not included in PH300 through PH306. See PH350 through PH358.

Comments: Using limited production techniques it is impossible to hold exact tolerances of complicated weatherstrips. These are closer than we expected and can be classified as very good.

PH308A	1955-57 Front Windshield Header Seal(RE)	13.00/ea.
PH308B	1955-57 Rear Windshield Header Seal (RE).....	Disc.
PH308BA	1955-57 Convertible Top Header Bow Retainer Strips (RE)	74.00/pr.
PH308BC	1959-60 Convertible Top Header Bow Retainer Strips (RE)	Inquire
PH308BE	1961-61 Convertible Top Header Bow Retainer Strips (RE)	Inquire

Note: These strips are used to secure convertible top and weather stripping where the header and convertible top meet over the front windshield.

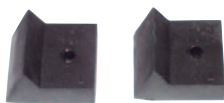

PH308C

PH308C	1955-57 Quarter Window Stops (RE)	11.00/pr.
---------------	---	-----------



PH308D



PH308DF

PH308D	1955-57 Rear Quarter Drain Seals and Roof Rail Stops (RE)	44.00/set
PH308DF	1967-68 Convertible Quarter Window Rear Filler W/S (RE)	77.00/set

PH308F	1955-57 Convertible Top Side Roof Rail Slat Iron Bumpers (RE)	\$29.00/pr.
PH309	1958-64 Windshield Header Seal (RE)	11.00/ea.
PH309AA	1965-66 Windshield Header Seal (RE)	20.00/ea.
PH309A	1967-70 Rubber Windshield Header Seal w/Molded Corners (RE)	48.00/ea.

PH309A is the rubber weatherstrip that seals the convertible top frame to the windshield header. May also be used on '65-'66 models if molded corners are desired.

PH320	1971-75 Windshield Header Seal (GM)	Disc.
PH320A	1971-75 Windshield Header Seal (RE)	69.00/ea.
PH330	1965-75 Convertible Top Header Bow Edging (AP)	10.00/ea.

This is the black molding that finishes the back edge of the header bow.

CONVERTIBLE PILLAR POST WEATHERSTRIP



PH357

PH350	1955-58 Windshield Pillar Post Weatherstrips, (RE)	Disc.
PH350A	1955-58 Windshield Pillar Post Weatherstrips, (RE)	6.50/pr.

Note: This weatherstrip functions fine. PH350A also fits hardtops and Safari Wagons.

PH352	1959-60 Windshield Pillar Post Weatherstrips (RE)	49.00/pr.
PH353	1961 Windshield Pillar Post Weatherstrips (RE)	49.00/pr.
PH353B	1962 Windshield Pillar Post Weatherstrips (RE)	49.00/pr.
PH354	1963-64 Windshield Pillar Post Weatherstrips (RE)	49.00/pr.
PH355	1965 Windshield Pillar Post Weatherstrips (RE)	49.00/pr.
PH356	1966-68 Windshield Pillar Post Weatherstrips (RE)	52.00/pr.
PH357	1969-70 Windshield Pillar Post Weatherstrips (RE)	49.00/pr.
PH358	1971-75 Windshield Pillar Post Weatherstrips (RE)	49.00/pr.

Note: Pillar post weatherstrip runs along the side of the windshield. These reproductions have the correct molded ends and fit well.

Comments: Very good—since they are extruded rubber these weatherstrips are harder than original but soon conform to shape.

VINYL TOPS



PH400	1969-72 Vinyl Top - GP (RE)	99.00/ea.
--------------	-----------------------------------	-----------

Note: These vinyl tops are universal fit. They fit all '69-72 GP, but the grain and seams may not look exactly like the original top.

Colors available are black and white.

REAR 1/4 TRIM

EMBLEMS & ORNAMENTS



PJ101 1955 Rear 1/4 "V8" Emblems (APE) \$55.00/pr.
 Note 1: PJ101 will also fit 1956 front fender; however, 1956 did not use the white border found on 1955's.
 Note 2: These are high-quality die-cast pieces.



PJ101G 1955,57 Chrome Star Ornament
 - 2 prong (RE) 15.00/ea.
 Note: This ornament has two mounting pins and was used until early 1957.

PJ101H 1957-58 Chrome Star Ornament
 - 3 prong (RE) 15.00/ea.
 Note: This ornament has three mounting pins and was used in late 1957 through 1958.



PJ101M 1957-58 "Safari" Rear 1/4 Panel Emblem,
 LH or RH (RE) 48.00/ea.



PJ102H 1959 Bonneville Rear 1/4 Ornament,
 LH or RH (RE) 35.00/ea.
 8 required per car.
 Chrome quality is fair to good.



PJ103 1963 Grand Prix 1/4 Panel Emblems (RE)..... 74.00/pr.



PJ104 1964 "Catalina" Rear 1/4 Panel Emblem (RE) \$29.00/ea.



PJ104D 1964 Rear 1/4 Panel "Bonneville" Letters
 (10 Piece Set) (RE) 83.00/set
 2 sets required per car.



PJ104Y 1965 Grand Prix Rear 1/4 Panel Emblems (RE) 109.00/pr.
 Note: PJ104Y is 3/16" shorter than originals. Overall length is 10 3/16" and center to center pin location is 7 13/16"



PJ105 1965 "2+2" Rear 1/4 Panel Emblems (RE) 130.00/pr.



PJ105Y 1966 "Catalina" Rear 1/4 Panel Emblem (RE) 40.00/ea.



PJ106 1966 "2+2" Rear 1/4 Panel Emblems (RE) Disc.



PJ107J 1967 Rear 1/4 Panel "Bonneville" Letters
 (10-piece set), exc. SW - LH Side (RE)... 105.00/set
 PJ107J will not fit on the left hand side of wagaons.
PJ107K 1967 Rear 1/4 Panel "Bonneville" Letters
 (20-piece set), exc. SW (RE) 199.00/2 sets

REAR QUARTER TRIM



PJ107M 1967 "2+2" Rear 1/4 Panel Emblem (RE) \$26.00/ea.



PJ107P 1967-68 Rear 1/4 Panel "Grand Prix" Letters (9-piece set) (RE)..... 93.00/set
PJ107R 1967-68 Rear 1/4 Panel "Grand Prix" Letters (18-piece set) (RE)..... 179.00/2 sets

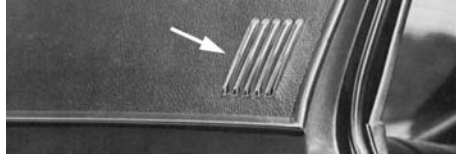

PJ109J 1969 Sail Panel Louvers, Type 1 - GP (RE) 9.00/ea.
PJ109K 1969 Sail Panel Louvers, Type 1 - GP (10-piece set) (RE)..... 83.00/set

It appears there were two styles of louvers used on '69 GPs. The PJ109J and PJ109K measure 4" long with a center to center pin distance of 2 7/8". We now have PJ109M and PJ109N that are 4" long with a center to center pin distance of 3 3/8". Please check original hole dimensions before ordering.

PJ109M 1969 Sail Panel Louvers, Type 2 - GP (RE) 9.00/ea.
PJ109N 1969 Sail Panel Louvers, Type 2 - GP (10-piece set) (RE)..... 85.00/set



PJ109R 1970 "Grand Prix" Pillar Emblem (RE) 39.00/ea.
 PJ109R has a satin finish with black outline

PJ110 1971-72 "Grand Prix" Pillar Emblems (RE) 55.00/pr.
 Note: PJ103 through PJ110 are low-pressure castings. The Overall quality is good.

PJ115 Rear 1/4 Panel Emblem Plastic Nut (RE) 2.50/ea.
 These are used for emblems with 3/16" stud size.



PJ115 Rear 1/4 Panel Emblem Plastic Nut (RE) 2.50/ea.

BEZELS & LENSES



PJ120 1968 Rear Side Marker Bezel - Exc. GP (RE) .. 50.00/pr.
 Note: PJ120 are die-cast reproductions.

PJ120A 1968 Rear Side Marker Bezel - Exc. GP (RE) .. 45.00/pr.
 Note: PJ120A are low-pressure castings.

PJ121 1968 Rear Side Marker Lens - Exc. GP (RE).... 19.00/pr.
 Comments: Reproductions are excellent.



PJ121C 1968 Rear Side Marker Gaskets
 - Exc. GP (RE) \$5.00/pr.



PJ121D 1968 Rear Side Marker Light Ground Strap
 - Exc. GP (RE) 10.00/pr.

1/4 WINDOW REGULATOR COMPONENTS



PJ178 1955-57 Window Regulator Handle w/ Washer (RE)..... 32.00/pr.

These handles are meant to be used as replacements. They are chrome-plated and utilize a black knob.

PJ179 1958-64 Window Regulator Handle - All '58 exc. Chieftain, '59-'64 Catalina (AP)..... 6.00/ea.



PJ180 1959-64 Window Regulator Handle
 - Exc. Catalina (RE) 13.00/ea.

PJ181 1965-66 Window Regulator Handle (GM) 88.00/ea.

Comments: This handle exhibits a poor quality finish. Suggested only if using GM is a must.

PJ182 1965-66 Window Regulator Handle (RE) 14.00/ea.

This is an excellent alternative to the high-priced poor quality handle offered by GM.



PJ184 1967 Window Regulator Handle, Black Knob (RE)..... 11.00/ea.

This is a very good reproduction of the 1967 - only regulator handle. Available in black only.

PJ185 1968-77 Window Regulator Handle (Black Knob) (GM) 36.00/ea.

PJ185A 1968-77 Window Regulator Handle (Black Knob) (AP)..... 5.00/ea.

PJ186 1968-77 Window Regulator Handle, Clear Knob (GM)..... Disc.

PJ186A 1968-77 Window Regulator Handle, Clear Knob (AP) 5.00/ea.

Note 1: All regulator handles come with locking spring clips.

Note 2: Although not an exact replacement, the GM window regulator handles are the best quality handles available. PJ185A and PJ186A are offered as inexpensive alternatives. Can be used on 1967 also but knob is incorrect design.

REAR QUARTER TRIM



PJ190

- PJ190** 1967-77 Window Regulator Handle Replacement Knob (RE)..... \$7.00/pr.

Although colored knobs are not original for '69 and up, these are an attractive accessory for daily driver cars.

Colors available: black, white, red, and medium blue.



PJ194

- PJ194** Door Panel Sealing Foam Washers (RE) 4.50/pr.

This is the foam washer located between the panel board and door shell. Applications may vary.



PJ195

- PJ195** 1955-77 Window Regulator Handle Washer (GM)..... 6.00/ea.



PJ195C

- PJ195A** 1955-77 Window Regulator Handle Washer (RE)..... 1.50/ea.



PJ195F

- PJ195C** 1961-77 Window Regulator Handle Spring (RP)..... 1.50/ea.

These are the springs behind the window regulator handle.

- PJ195F** 1955-77 Window Regulator Handle Clip -All (RE) 1.00/ea.



PJ195R

- PJ195R** 1959-77 Regulator and Door Handle Spring Clip Removal Tool (AP) 5.50/ea.



PJ196B

- PJ196** 1969-72 Rear Quarter Window Lower Roller (Roller Only) - GP (RE)..... 4.50/ea.

Note: 2 required per car.

- PJ196B** 1969-72 Rear Quarter Window Lower Roller Guide Assembly - GP (RE)..... 9.50/ea.

Note: 2 required per car.

PJ196B Includes the roller and hardware to attach to the glass.

POWER WINDOW MOTORS



- PJ196L** 1955-58 Rear Power Window Motor - LH (RP)..... \$92.00/ea.
PJ196R 1955-58 Rear Power Window Motor - RH (RP) 92.00/ea.

Note: These motors are replacements for 1955 to '58 Pontiacs with 12-tooth drive gears.

- PJ197L** 1959-71 Rear Power Window Motor - LH (RE)..... 92.00/ea.
PJ197R 1959-71 Rear Power Window Motor - RH (RE)..... 92.00/ea.
PJ198L 1972-76 Rear Power Window Motor - LH (RE)..... 92.00/ea.
PJ198R 1972-76 Rear Power Window Motor - RH (RE)..... 92.00/ea.

QUARTER WINDOW WEATHERSTRIPS

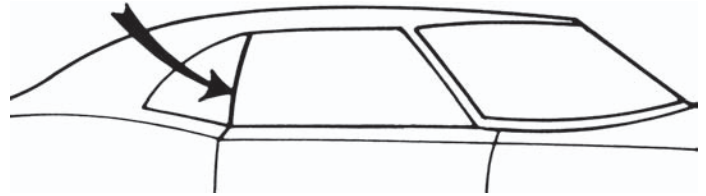

- PJ200** 1955-57 Quarter Window Weatherstrips (Cloth covered w/Steel Insert) (RE)..... Disc.
PJ201 1955-57 Quarter Window Weatherstrips (Rubber w/o Steel Insert) (RE) 10.00/pr.
PJ201A 1955-57 Quarter Window Weatherstrips - 2 Dr. Sedan (RE) 29.00/pr.
PJ201C 1955-57 Quarter Window Weatherstrips - Safari (RE) 19.00/pr.

These are made specifically for the slide-open side windows on Safaris.

- PJ201J** 1958 Quarter Window Weatherstrips (Cloth covered w/Steel Insert) - CVT (RE)..... Disc.
PJ201K 1958 Quarter Window Weatherstrips (Cloth covered w/Steel Insert) - 2 Dr. HT (RE)..... Disc.
PJ202 1958-64 Quarter Window Weatherstrips (Rubber w/o Steel Insert) - All (RE) 10.00/pr.
PJ202J 1959-60 Quarter Window Weatherstrips (Rubber w/Steel Insert) - CVT (RE)..... 19.00/pr.
PJ202K 1959-60 Quarter Window Weatherstrips (Rubber w/Steel Insert) - 2 Dr. HT (RE) .. 19.00/pr.
PJ202M 1959-60 Quarter Window Weatherstrips - 4 Dr. HT (RE)..... 29.00/pr.
PJ203 1965-66 Quarter Window Weatherstrips (Rubber w/Steel Insert) - 2 Dr.'s (RE)..... 19.00/pr.

Quarter Window Weatherstrip continued on next page

Quarter Window Weatherstrip continued

- PJ204** 1965-66 Rear Door Window Front Weatherstrips (Rubber w/o Steel Insert) - 4 Dr. HT (RE)..... \$12.00/pr.
- PJ206** 1967-68 Quarter Window Weatherstrips (Rubber w/o Steel Insert) - 2 Dr.'s (RE) ... 14.00/pr.

Note: This weatherstrip does not fit '67 GP CVT.

- PJ206J** 1967-68 Quarter Window Weatherstrips (Rubber w/Steel Insert) - CVT (RE)..... 20.00/pr.

Note: This weatherstrip does not fit '67 GP CVT.

- PJ209** 1969-70 Quarter Window Weatherstrips (Rubber w/Steel Insert) - FS (RE)..... 20.00/pr.
- PJ210** 1969-72 Quarter Window Weatherstrips (Rubber w/ Steel Insert) - GP (RE)..... 20.00/pr.

- PJ211A** 1971-74 Quarter Window Weatherstrips (Rubber w/Steel Insert) -Grandville 2 Dr.HT (RE) 39.00/pr.

Note: PJ211A will work on '71-'73 Grandville convertibles but must be cut down in length.

- PJ212A** 1971-73 Quarter Window Weatherstrips (Rubber w/Steel Insert) - 2Dr. HT, CVT exc. Grandville (RE) 26.00/pr.

- PJ212A** 1974-75 Quarter Window Weatherstrips (Rubber w/Steel Insert)-Grandville CVT (RE) 26.00/pr.

Note: Several of these reproduction quarter window weatherstrips do not have steel reinforcements. Although not as rigid as the originals, they seal well.

SASH CHANNELS



- PJ220L & R
- PJ219** 1955-57 Rear 1/4 Window Sash Channel - 2 Dr. HT & CVT, LH or RH (RE) 26.00/ea.
 - PJ219D** 1958 Rear 1/4 Window Sash Channel - 2 Dr. HT & CVT, LH or RH (RE) 26.00/ea.
 - PJ219F** 1959-60 Rear 1/4 Window Sash Channel - 2 Dr. HT & CVT, LH or RH (RE) 26.00/ea.

PJ219 through PJ219F are riveted to the quarter glass assembly to hold the 1/4 window weatherstripping.

- PJ220L** 1969-72 Rear 1/4 Window Sash Channel, LH -GP (RE)..... 35.00/ea.
- PJ220R** 1969-72 Rear 1/4 Window Sash Channel, RH -GP (RE)..... 35.00/ea.
- PJ220L** 1969-70 Rear 1/4 Window Sash Channel, LH -FS (RE) 35.00/ea.
- PJ220R** 1969-70 Rear 1/4 Window Sash Channel, RH - FS (RE) 35.00/ea.

PJ220L & R are the chrome strips that attach to the front of the rear quarter window and hold the rear 1/4 window weatherstrip.



PJ222BL

- PJ222BL** 1955-57 Rear 1/4 Window Adjusting Plate, LH - CVT (RE)..... 15.00/ea.
- PJ222BR** 1955-57 Rear 1/4 Window Adjusting Plate, RH - CVT (RE)..... 15.00/ea.

These are the knurled plates that adjust the rear 1/4 window in and out.

CHROME WINDOW FRAMES

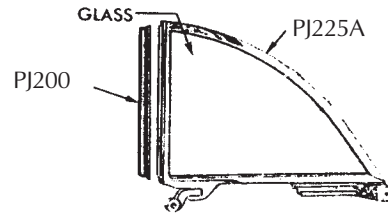

- PJ225** 1955-57 Upper Quarter Window - Chrome Frame - 2 Dr. HT, LH or RH (RE)..... \$79.00/ea.
- PJ225A** 1955-57 Upper Quarter Window - Chrome Frame - Conv., LH or RH (RE)..... 95.00/ea.
- PJ225D** 1958 Upper Quarter Window - Chrome Frame - Bonneville 2 Dr. HT, LH or RH (RE)..... 72.00/ea.
- PJ225F** 1958 Upper Quarter Window - Chrome Frame - Bonneville CVT, LH or RH (RE) 104.00/ea.
- PJ225J** 1959-60 Upper Quarter Window - Chrome Frame - 2 Dr. HT, LH or RH (RE)..... Inquire
- PJ225K** 1959-60 Upper Quarter Window - Chrome Frame - CVT, LH or RH (RE)..... 93.00/ea.

SETTING CHANNEL

- PJ228J** Window Glass Setting Channel, Rubber - .032" (GM)..... 1.00/ft.
- PJ228K** Window Glass Setting Channel, Rubber - .047" (GM)..... 1.00/ft.

These are the rubber setting strips used to adhere chrome frames to windows.

REAR SIDE GLASS CHANNELS

- PJ230** 1955-57 Side Glass Channels - 2 Dr. Safari (RE) . 89.00/pr.
- PJ231** 1955-57 Side Glass Channels - 2 Dr. SW (RE) 59.00/pr.
- PJ232** 1955-57 Side Glass Channels - 4 Dr. SW (RE) 59.00/pr.



PJ241

- PJ241** 1973-77 Opera Window Molding - GP (RE)..... 149.00/pr.
- Quality: Very Good. Does not include corner escutcheons.

OWN OTHER PONTIACS?

Call or visit www.amesperf.com for your Free:



**1967-1981
Firebird
Trans Am
Formula
Catalog**

or

**1964-1977
GTO
Lemans
Tempest
1971-1974
Ventura**



REAR QUARTER TRIM



PJ233

- PJ233** 1955-57 Side Glass Channels
- 4 Dr. Sedan (RE) \$51.00/pr.

Note: PJ230 through PJ233 are the rubber channels that hold the rear side glass in place.

- PJ234** 1955-57 Safari Rear Curved Glass Stops (RE) 3.50/pr.



PJ234C

- PJ234C** 1955-57 Rear 1/4 Window Stops, CVT (RE) 6.50/pr.

LOCK PILLAR WEATHERSTRIPS

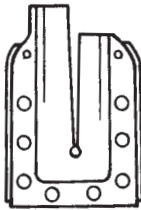

- PJ247** 1955-57 Lock Pillar Weatherstrip
- 2 Dr. HT (RE) 29.00/pr.
- PJ248** 1955-57 Lock Pillar Weatherstrip
- CVT (RE) Inquire
- PJ249** 1956-57 Lock Pillar Weatherstrip
- 4 Dr. HT (RE) 26.00/set
- PJ250** 1958 Lock Pillar Weatherstrips
- 2 Dr. HT (RE) 19.00/pr.
- PJ251** 1958 Lock Pillar Weatherstrips
- CVT (RE) 19.00/pr.
- PJ252** 1959-60 Lock Pillar Weatherstrips
- 2 Dr. HT (RE) 28.00/pr.
- PJ253** 1959-60 Lock Pillar Weatherstrips
- CVT (RE) 19.00/pr.
- PJ254** 1959-60 Lock Pillar Weatherstrips
- 4 Dr. HT Front Door (RE) 26.00/pr.
- PJ254A** 1959-60 Lock Pillar Weatherstrips
- 4 Dr. HT Rear Door (RE) 33.00/pr.
- PJ255** 1961-64 Lock Pillar Weatherstrips
- 2 Dr. HT (RE) 19.00/pr.
- PJ256** 1961-64 Lock Pillar Weatherstrips
- CVT (RE) 19.00/pr.
- PJ257** 1961-64 Lock Pillar Weatherstrips
- 4 Dr. HT Front Door (RE) 7.50/pr.
- PJ257A** 1961-64 Lock Pillar Weatherstrips
- 4 Dr. HT Rear Door (RE) 25.00/pr.
- PJ260** 1965-66 Lock Pillar Weatherstrips
2 Dr's (RE) 20.00/pr.
- PJ260B** 1965-66 Lock Pillar Weatherstrips
- 4Dr. HT & Sedan (RE) 25.00/pr.
- PJ265** 1967-68 Lock Pillar Weatherstrips (RE) 23.00/pr.

1967-68 used two different lock pillar weatherstrips. PJ265 measures 2 3/4" x 3 3/4" and PJ265A measures 2 3/4" x 4 3/4". Please measure your original before placing your order.

- PJ265A** 1967-68 Lock Pillar Weatherstrips (RE) 22.00/pr.
- PJ268** 1969-70 Lock Pillar Weatherstrips - FS (RE) 23.00/pr.
- PJ270** 1969-72 Lock Pillar Weatherstrips - GP (RE) 20.00/pr.
- PJ272** 1971-75 Lock Pillar Weatherstrips - FS (RE) 22.00/pr.

Note: Lock pillar weatherstrip seals the bottom of the quarter window at the lock pillar. These reproductions are manufactured with steel like the originals.

DOOR JAMB LOUVERS



PJ280A

- PJ279** 1969-72 Door Jamb Louver w/Seal - GP (RE) \$19.00/ea.

Note: This louver comes with the one way seal like original.

- PJ280A** 1969-72 Door Jamb Louver - GP (RE) 23.00/ea.

Note: This louver does not have the one-way flapper attached to it.

BODY SIDE MOLDING CLIPS



PJ290

- PJ290** Plastic Body Side Molding Clip (RE) 2.00/ea.

Overall dimensions: .330" x .820" Fits .220" x .500" hole.

- PJ290A** Plastic Body Side Molding Clip (RE) 2.00/ea.

Overall dimensions: .435" x .960" Fits .300" x .550" hole.

- PJ290B** Plastic Body Side Molding Clip (RE) 2.00/ea.

Overall dimensions: .600" x .960" Fits .300" x .550" hole.

PJ290 - PJ290B are used on many different cars. Refer to photo and dimensions for your application.

SHEET METAL PLUGS



PJ300



PJ302

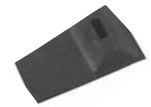

PJ304

- PJ299** 3/8-Inch Sheet Metal Body Plug (Rubber) (AP) 1.50/ea.
- PJ299B** 1/2-Inch Sheet Metal Body Plug (Rubber) (AP) 1.50/ea.
- PJ299D** 5/8-Inch Sheet Metal Body Plug (Rubber) (AP) 1.50/ea.
- PJ300** 3/4-Inch Sheet Metal Body Plug (Plastic) (AP) 1.50/ea.
- PJ301** 3/4-Inch Sheet Metal Body Plug (Rubber) (RP) 2.50/ea.
- PJ301B** 7/8-Inch Sheet Metal Body Plug (Rubber) (AP) 2.50/ea.
- PJ302** 1-Inch Sheet Metal Body Plug (Rubber) (RP) 1.50/ea.
- PJ303** 1-Inch Sheet Metal Body Plug (Plastic) (AP) 1.50/ea.
- PJ303B** 1 1/4-Inch Sheet Metal Body Plug (Rubber) (AP) 3.50/ea.
- PJ304** Rocker Panel Drain Plug (RE) 1.50/ea.

This rectangular plug is found in the inner rocker panel in front of the rear wheelwell.



www.takeakidtoacarshow.com



PJ320

- PJ320** 1960-63 Rear 1/4 and Tailgate Wiring Grommet - SW (RE)..... \$12.00/ea.

These were used to pass wiring from the 1/4 panel to the tailgate on station wagons.

FENDER SKIRT COMPONENTS

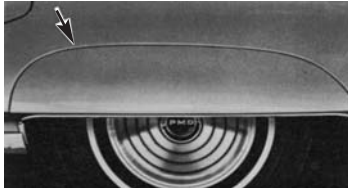

- PJ350** 1955-57 Fender Skirt to Body Gasket (RE) 13.00/pr.
- PJ351** 1958-64 Fender Skirt to Body Gasket (RE) 13.00/pr.
- PJ353** 1967-68 Fender Skirt to Body Gasket (RE) 37.00/pr.



PJ380

- PJ380** 1965-66 Fender Skirt Bracket Set (RE) Inquire
- These are the brackets used to attach the skirts to the rear quarter.

SEAM SEALER



PJ400

- PJ400** Seam Sealer, Tan (AP) 15.00/tube

B-PILLAR PATCH PANELS



PJ510L

- PJ510L** 1955-57 B-Pillar Brace, LH - CVT (RE) 159.00/ea.
- PJ510R** 1955-57 B-Pillar Brace, RH - CVT (RE) 159.00/ea.



PJ518L

- PJ518L** 1955-57 Complete B-Pillar Panel, LH - 2Dr. HT & CVT (RE)..... 169.00/ea.
- PJ518R** 1955-57 Complete B-Pillar Panel, RH - 2Dr. HT & CVT (RE)..... 169.00/ea.

PJ518L and PJ518R will replace the rear of the front door opening at the front of the quarter panel. They extend from the top of the quarter down to the rocker panel and include the cutouts for the striker latch mechanisms.

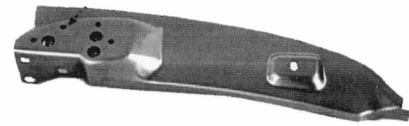

PJ519L

- PJ519L** 1955-57 Door Jamb Reinforcement, LH - 2 Dr. HT & CVT (RE)..... \$199.00/ea.

- PJ519R** 1955-57 Door Jamb Reinforcement, RH - 2 Dr. HT & CVT (RE)..... 199.00/ea.

PJ519L and PJ519R are the door jamb reinforcement braces behind the B-pillars. Made with heavy gauge steel components and an adjustable door jamb striker latch mounting plate with pre-threaded holes.



PJ520L

- PJ520L** 1955-57 B-Pillar Lower Patch Panel, LH - 2Dr. HT & CVT (RE)..... 99.00/ea.

- PJ520R** 1955-57 B-Pillar Lower Patch Panel, RH - 2Dr. HT & CVT (RE) 99.00/ea.

PJ520L and PJ520R will replace just the lower portion of the B-Pillar.

WHEELHOUSE SEALS

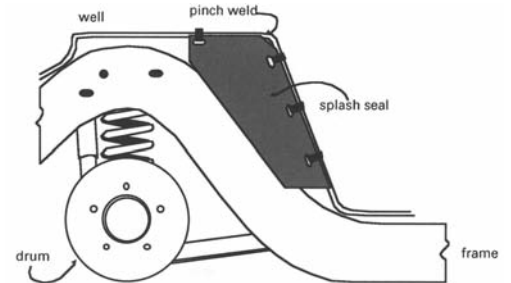

- PJ540** 1962-64 Rear 1/4 Inner Wheelhouse to Frame Seals - Exc. Bonneville & SW (APE) Inquire

- PJ540A** 1962-64 Rear 1/4 Inner Wheelhouse to Frame Seals w/Clips - Exc. Bonneville & SW (APE) Inquire

- PJ541** 1961-64 Rear 1/4 Inner Wheelhouse to Frame Seals - Bonneville, Exc. SW (APE)..... 15.00/pr.

- PJ541A** 1961-64 Rear 1/4 Inner Wheelhouse to Frame Seals w/Clips - Bonneville, Exc. SW (APE) 21.00/pr.

INNER WHEELHOUSE PANELS



PJ580L

- PJ580L** 1969-72 Inner Wheelhouse Panel, LH - GP (RE)..... 115.00/ea.

- PJ580R** 1969-72 Inner Wheelhouse Panel, RH - GP (RE) 115.00/ea.

Add \$28.00 oversize fee to standard shipping for PJ580L & PJ580R.



REAR QUARTER TRIM

TRUNK COMPONENTS

TRUNK MATS



Pontiac used many colors and designs for its trunk mats from 1955-'77. We have several new patterns and colors. We should be able to match most original trunk component materials with our product line.

The following trunk mat materials are available for the years listed:

- Tan and Brown Chainlink (1955-56), TBC
- Gray and Black Crowsfoot (1955-57), GBC
- Gray and Red Crowsfoot (1955-57), GRC (Disc.)
- Gray and White Crosshatch (1958), GWC (Inquire)
- Gray and Black Houndstooth (1959), GHT
- Red and Black Houndstooth (1960), RHT
- Red, Fawn, and Black Herringbone (1961), RFB
- Red and Black Herringbone (1962-64), RBH
- Aquamarine and Black Herringbone (1962-64), AHB
- Gray and Green Gator (1965-66), GAT
- Gray and Black Herringbone (1967-68), GHB
- Gray-Green Felt (1969-77), FGG
- Black Felt (1969-70), BF

Matching trunk mats, side panels, and spare tire covers will be available in these new colors and patterns.

As dye lot changes and different materials are used, colors may vary. Side panels, trunk mats, spare tire covers and trunk dividers will not always be exact matches since all are made from different materials (ex. cardboard, rubber, and vinyl).

Add \$7.00 oversize fee to standard shipping for rubber trunk mats.

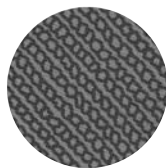

PK100F



- PK100F** 1955-56 Chainlink Trunk Mat Material, All (RE) . \$169.00/roll
This material has the correct printing and is made from the original style cloth. We are selling this in a 3 1/2 yard roll. The roll is 56" wide and in most cars, must be used with a backing for proper appearance. Must be cut to fit.
- PK101** 1955-56 Trunk Mat, Rubber -Star Chief 2 Dr.HT - GBC (RP) 69.00/ea.
- PK101A** 1955-56 Trunk Mat, Rubber -Star Chief CVT - GBC (RP) 65.00/ea.
- PK102** 1957 Trunk Mat - Star Chief (RE) Inquire
- PK102A** 1957 Trunk Mat - Star Chief & Bonneville CVT (RE)..... Inquire
- PK102C** 1957 Trunk Mat - Chieftain 2 Dr. HT (RE) Inquire

- PK104** 1958 Trunk Mat - Bonneville & Chieftain 2 Dr. HT(RE) Inquire
- PK104A** 1958 Trunk Mat - Bonneville & Chieftain CVT (RE)..... Inquire
- PK104C** 1958 Trunk Mat - Star Chief & Superchief 2 Dr. HT (RE) Inquire

These correct horsehair backed mats with the silkscreened crosshatch face is currently unavailable.

- PK106** 1959 Trunk Mat - Catalina - GHT (RE)..... \$65.00/ea.
- PK107** 1959 Trunk Mat - Bonneville & Star Chief - GHT (RE) 65.00/ea.
- PK108** 1960 Trunk Mat - Catalina & Ventura 2 Dr. HT & CVT - RHT (RE)..... 58.00/ea.
- PK108B** 1960 Trunk Mat - Catalina & Ventura 4 Dr. Sedan - RHT (RE)..... 58.00/ea.
- PK109** 1960 Trunk Mat - Bonneville & Star Chief - RHT (RE)..... 65.00/ea.
- PK110** 1961 Trunk Mat - Catalina & Ventura HT - RFB (RE)..... 59.00/ea.
- PK110A** 1961 Trunk Mat - Catalina & Ventura CVT - RFB(RE) 55.00/ea.
- PK111** 1961 Trunk Mat - Bonneville & Star Chief 2 Dr. HT & CVT - RFB (RE)..... 59.00/ea.
- PK111B** 1961 Trunk Mat - Bonneville & Star Chief 4 Dr. HT - RFB (RE)..... 69.00/ea.

Note: 1962-64 trunk mats are available in red and black herringbone or aquamarine and black herringbone. Please specify color when ordering.

- PK112** 1962 Trunk Mat - Catalina & GP 2 Dr. HT & Sedan (RE) 55.00/ea.
- PK112A** 1962 Trunk Mat - Catalina CVT (RE)..... 55.00/ea.
- PK113** 1962 Trunk Mat - Bonneville & Star Chief 2 Dr. HT & CVT (RE)..... 55.00/ea.
- PK114** 1963-64 Trunk Mat - Catalina 2 Dr. HT (RE)..... 55.00/ea.
- PK114A** 1963-64 Trunk Mat - Catalina CVT (RE)..... 55.00/ea.
- PK114B** 1963-64 Trunk Mat - Catalina 4 Dr. HT (RE) 55.00/ea.
- PK114C** 1963-64 Trunk Mat - Catalina 4 Dr. Sedan (RE) ... 55.00/ea.
- PK115** 1963-64 Trunk Mat - Bonneville & Star Chief 2 Dr. HT & CVT (RE) 55.00/ea.
- PK115B** 1963-64 Trunk Mat -Bonneville & Star Chief 4 Dr. HT (RE)..... 55.00/ea.
- PK119** 1963 Trunk Mat - GP (RE) 55.00/ea.
- PK119A** 1964 Trunk Mat - GP (RE) 55.00/ea.
- PK120** 1965-66 Trunk Mat - Catalina & 2+2 HT - GAT (RE) 55.00/ea.
- PK120A** 1965-66 Trunk Mat - Catalina & 2+2 CVT- GAT(RE) 55.00/ea.
- PK121** 1965 Trunk Mat - Bonneville & Star Chief exc. CVT -GAT (RE)..... 55.00/ea.
- PK121A** 1965 Trunk Mat - Bonneville & Star Chief CVT -GAT (RE)..... 55.00/ea.
- PK122C** 1965-66 Trunk Mat - Catalina 4 Dr. Sedan - GAT (RE)..... 55.00/ea.
- PK123** 1966 Trunk Mat - Bonneville & Star Chief - GAT (RE)..... 55.00/ea.
- PK123A** 1965-66 Trunk Mat - GP - GAT (RE) 55.00/ea.
- PK126** 1967-68 Trunk Mat - Catalina, GP & 2+2 - GHB (RE)..... 55.00/ea.
- PK126B** 1967-68 Trunk Mat - Catalina 4 Dr. HT - GHB (RE) 55.00/ea.
- PK126C** 1967-68 Trunk Mat - Catalina 4 Dr. Sedan -GHB (RE)55.00/ea.
- PK127** 1967-68 Trunk Mat - Bonneville & Executive 2 Dr. HT -GHB (RE)..... 59.00/ea.
- PK127A** 1967 Trunk Mat - Bonneville & Executive CVT - GHB (RE)..... 55.00/ea.
- PK128A** 1968 Trunk Mat - Bonneville & Executive CVT - GHB (RE)..... 55.00/ea.

Trunk Mats continued on next page.

TRUNK COMPONENTS

ACCESSORY TRUNK MAT



PK170

PK170 1967-72 Accessory Trunk Mat - All (RE) \$139.00/ea.

After many years in development stage, PK170 is now available! Replicated from the original GM accessory part # 984785, listed as an option from 1967-71, this mat will also work in 1964-66 and 1972 mid-size and full-size Pontiacs. Along with the original unique rib pattern and dual arrowheads, we have taken the liberty of making our own improvements; Made in a durable black rubber (originals were drab gray) and accented with silver inlay to accentuate the arrowheads much like our accessory floor mats, this will be a great addition to your trunk area. As with originals, the area that covers the spare tire and jack supports will need to be located and cut out upon installation.

Add \$9.00 oversize fee to standard shipping for PK170



TRUNK SIDE PANEL CLIPS



PK195



PK195A

PK195 1963-77 Trunk Side Panel Clip (GM)..... 4.00/ea.

PK195A 1961-77 Original Style Steel Trunk Side Panel Clip (RE) 4.00/ea.

PK195 and PK195A are the clips that are used to secure side panels to the inner trunk framework. GM has superseded this part to a plastic push pin now.

Trunk Mats continued.

PK134	1969-70	Trunk Mat - Catalina 2 Dr. HT - FGG (RE)	\$36.00/ea.
PK134A	1969-70	Trunk Mat - Catalina CVT - FGG (RE)....	36.00/ea.
PK134C	1969-70	Trunk Mat - Catalina 4 Dr. Sedan - FGG (RE)	52.00/ea.
PK135	1969-70	Trunk Mat - Bonneville 2 Dr. HT (RE)....	Inquire
PK135A	1969-70	Trunk Mat - Bonneville CVT - Black Felt (RE)	69.00/ea.
PK137	1969	Trunk Mat - GP - FGG (RE)	39.00/ea.
PK138	1970	Trunk Mat - GP - FGG (RE)	34.00/ea.
PK140	1971-72	Trunk Mat - Catalina 2 Dr. HT - FGG (RE)	32.00/ea.
PK140A	1971-72	Trunk Mat - Catalina CVT - FGG (RE)...	34.00/ea.
PK141	1971-72	Trunk Mat - Bonneville 2 Dr. HT - FGG (RE)	34.00/ea.
PK141A	1971-72	Trunk Mat - Bonneville CVT - FGG (RE)	Inquire
PK141C	1971-72	Trunk Mat - Bonneville 4 Dr. Sedan - FGG (RE)	49.00/ea.
PK142	1971-72	Trunk Mat - GP - FGG (RE)	34.00/ea.
PK148A	1973-75	Trunk Mat - Grandville CVT - FGG (RE)	42.00/ea.
PK149D	1973-75	Trunk Mat - Grandville 4 Dr. HT - FGG (RE)	36.00/ea.
PK150	1973-77	Trunk Mat - GP - FGG (RE)	34.00/ea.

If you do not find your trunk mat listed above, please inquire. We are looking for new patterns to complete our listing.

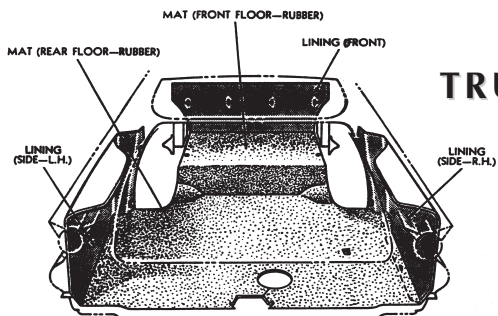

TRUNK SIDE PANELS

In most applications, side panels are available with our trunk mats. We can coordinate design and material in order to complete the total restoration of your trunk area.

Trunk side linings are now printed cardboard like originals and are available in the same colors as trunk mats. **1962-64** side panels are available in red and black herringbone or aquamarine and black herringbone. Please specify color when ordering.

Add \$15.00 oversize fee to standard shipping for trunk side panels.



PK203	1958	Trunk Side Panels - Bonneville - 2 Dr. HT - GWC (RE)	Inquire
PK203A	1958	Trunk Side Panels - Bonneville CVT -GWC (RE)	Inquire
PK204	1959	Trunk Side Panels - Catalina - 2 Dr. HT - GHT (RE)	\$65.00/pr.
PK204A	1959	Trunk Side Panels - Catalina CVT-GHT (RE)	79.00/pr.
PK204B	1959	Trunk Side Panels - Catalina 4 Dr. HT - GHT (RE)	65.00/pr.
PK205	1959	Trunk Side Panels - Bonneville 2 Dr. HT & 2 Dr. Sedan - GHT (RE)	59.00/pr.
PK205A	1959	Trunk Side Panels - Bonneville CVT - GHT (RE).....	59.00/pr.
PK205B	1959	Trunk Side Panels - Bonneville 4 Dr. HT & 4 Dr. Sedan - GHT (RE)	59.00/pr.
PK207	1960	Trunk Side Panels - Catalina & Ventura - 2 Dr. HT - RHT (RE).....	59.00/pr.
PK207A	1960	Trunk Side Panels - Catalina & Ventura - CVT - RHT (RE)	59.00/pr.
PK207B	1960	Trunk Side Panels - Catalina & Ventura - 4 Dr. HT - RHT (RE).....	59.00/pr.
PK208	1960	Trunk Side Panels - Bonneville & Star Chief - 2 Dr. HT - RHT (RE)	59.00/pr.
PK208A	1960	Trunk Side Panels - Bonneville & Star Chief - CVT - RHT (RE)	59.00/pr.
PK208B	1960	Trunk Side Panels - Bonneville & Star Chief - 4 Dr. HT & Sedan - RHT (RE)	59.00/pr.
PK209	1961	Trunk Side Panels - Catalina & Ventura - HT - RFB (RE)	65.00/pr.
PK209A	1961	Trunk Side Panels - Catalina & Ventura - CVT - RFB (RE)	65.00/pr.
PK210	1961	Trunk Side Panels - Bonneville & Star Chief - 2 Dr. HT - RFB (RE)	59.00/pr.
PK210A	1961	Trunk Side Panels - Bonneville & Star Chief - CVT - RFB (RE).....	89.00/pr.
PK211	1962	Trunk Side Panels - Catalina & GP - 2 Dr. HT - 4 Dr. Sedan (Specify red or aqua) (RE).....	59.00/pr.
PK211A	1962	Trunk Side Panels - Catalina CVT (Specify red or aqua) (RE)	65.00/pr.
PK212	1962	Trunk Side Panels - Bonneville & Star Chief - 2 Dr. HT & 4Dr. Sedan (Specify red or aqua) (RE)	65.00/pr.
PK212A	1962	Trunk Side Panels - Bonneville & Star Chief - CVT (Specify red or aqua) (RE).....	65.00/pr.
PK213	1963	Trunk Side Panels - Catalina, GP & Ventura - 2 Dr. HT (Specify red or aqua) (RE)	69.00/pr.
PK213B	1963-64	Trunk Side Panels - Catalina & Ventura - CVT (Specify red or aqua) (RE)	Inquire
PK214	1963-64	Trunk Side Panels - Bonneville & Star Chief - HT (Specify red or aqua) (RE).....	65.00/pr.
PK214A	1963-64	Trunk Side Panels - Bonneville & Star Chief - CVT (Specify red or aqua) (RE)	65.00/pr.
PK215C	1964	Trunk Side Panels - Catalina, GP & Ventura - 2 Dr. HT (Specify red or aqua) (RE)	59.00/pr.
PK217	1965-66	Trunk Side Panels - Catalina 2+2 & GP - 2 Dr. HT & 4 Dr. HT - GAT (RE).....	59.00/pr.
PK217A	1965-66	Trunk Side Panels - Catalina 2+2 CVT - GAT (RE).....	59.00/pr.

Trunk Side Panels continued on next page.

Trunk Side Panels continued.

PK218	1965-66	Trunk Side Panels - Bonneville & Star Chief - 2 Dr. HT - GAT (RE).....	\$89.00/pr.
PK218A	1965-66	Trunk Side Panels - Bonneville & Star Chief - CVT - GAT (RE).....	59.00/pr.
PK218B	1965-66	Trunk Side Panels - Bonneville & Star Chief - 4 Dr. HT - GAT (RE).....	65.00/pr.
PK219	1967	Trunk Side Panels - Catalina & 2+2 - 2 Dr. HT- GHB (RE)	59.00/pr.
PK219A	1967	Trunk Side Panels - Catalina & 2+2 CVT - GHB (RE).....	59.00/pr.
PK219B	1967	Trunk Side Panels - Catalina 4 Dr. Sedan - GHB (RE)	65.00/pr.
PK219C	1967	Trunk Side Panels - GP - GHB (RE).....	59.00/pr.
PK219D	1967	Trunk Side Panels - GP Cvt - GHB (RE).....	65.00/pr.
PK220	1967	Trunk Side Panels - Bonneville & Executive - 2 Dr. HT - GHB (RE).....	65.00/pr.
PK220A	1967	Trunk Side Panels - Bonneville & Executive - CVT - GHB (RE).....	59.00/pr.
PK220B	1967	Trunk Side Panels - Bonneville & Executive - 4 Dr. HT - GHB (RE).....	69.00/pr.
PK222	1968	Trunk Side Panels - Catalina & Ventura - 2 Dr. HT- GHB (RE)	65.00/pr.
PK222A	1968	Trunk Side Panels - Catalina & Ventura - CVT -GHB (RE)	Inquire
PK222B	1968	Trunk Side Panels - Catalina 4 Dr. HT - GHB (RE)	59.00/pr.
PK222C	1968	Trunk Side Panels - GP - GHB (RE).....	59.00/pr.
PK223	1968	Trunk Side Panels - Bonneville & Executive - 2 Dr. HT - GHB (RE).....	59.00/pr.
PK223A	1968	Trunk Side Panels - Bonneville & Executive - CVT - GHB (RE).....	65.00/pr.
PK224	1969	Trunk Side Panels - Catalina 2 Dr. HT - FGG (RE).....	65.00/pr.
PK224A	1969	Trunk Side Panels - Catalina CVT- FGG (RE)	65.00/pr.
PK225	1969	Trunk Side Panels - Bonneville & Executive - 2 Dr. HT, Black Only (RE)	59.00/pr.
PK225A	1969	Trunk Side Panels - Bonneville & Executive - CVT, Black Only (RE)	59.00/pr.
PK226A	1970	Trunk Side Panels - Catalina CVT - FGG (RE).....	59.00/pr.
PK227	1970	Trunk Side Panels - Bonneville & Executive - 2 Dr. HT - FGG (RE)	65.00/pr.
PK227A	1970	Trunk Side Panels - Bonneville & Executive - CVT, Black Only (RE)	85.00/pr.
PK227B	1970	Trunk Side Panels - Bonneville & Executive - 4 Dr. HT - FGG (RE)	70.00/pr.
PK228	1969-70	Trunk Side Panels - GP, Black Only (RE)	59.00/pr.
PK228D	1971	Trunk Side Panels - Catalina CVT-FGG (RE).....	62.00/pr.
PK229	1971-72	Trunk Side Panels - GP, Black Only (RE)	59.00/pr.
PK231B	1972	Trunk Side Panels - Bonneville & Executive - 4 Dr. Sedan - FGG (RE)	72.00/pr.
PK235A	1972	Trunk Side Panels - Grandville & Catalina - CVT - FGG (RE).....	89.00/pr.
PK239C	1973	Trunk Side Panels - Bonneville 4 Dr. Sedan - FGG (RE).....	65.00/pr.
PK240	1973-75	Trunk Side Panels - GP -FGG (RE)	59.00/pr.
PK244A	1973	Trunk Side Panels - Grandville CVT - FGG (RE)	90.00/pr.
PK249A	1974	Trunk Side Panels - Grandville CVT - FGG (RE)	90.00/pr.
PK249B	1974	Trunk Side Panels - Grandville 4 Dr. HT - FGG (RE).....	65.00/pr.

PK224A-PK249B (excluding PK225, PK225A, PK227A, PK228 and PK229) side panels have green-grey felt trunk mat material adhered to their face.

PK250A	1975	Trunk Side Panels - Grandville CVT - FGG (RE)	89.00/pr.
PK256	1976-77	Trunk Side Panels- GP, 6 pcs. - FGG (RE).....	65.00/set
PK256A	1976-77	Plain Trunk Side Panels - GP (RE)	49.00/set

PK256A is an un-covered version of PK256 - Black panel-board.

Add \$15.00 oversize fee to standard shipping for trunk side panels.



SPARE TIRE COVERS



Note: These covers are die-stamped and sewn in the same manner as factory originals. Samples available on request.

Comments: Very good—the only difference we see is a slightly smoother surface on the reproduction.

PK330	1959	Spare Tire Cover, Gray and Black Houndstooth (RE)	\$35.00/ea.
PK332	1960	Spare Tire Cover, Red and Black Houndstooth (RE).....	42.00/ea.
PK332A	1961	Spare Tire Cover, Red, Fawn and Black Herringbone (RE)	42.00/ea.
PK332B	1962-64	Spare Tire Cover, Red and Black Herringbone (RE)	42.00/ea.
PK332C	1962-64	Spare Tire Cover, Aquamarine and Black Herringbone (RE)	42.00/ea.
PK332D	1965-66	Spare Tire Cover, Gator (RE).....	42.00/ea.
PK333	1967-68	Spare Tire Cover, Gray and Black Herringbone (RE)	42.00/ea.
PK334	1969-up	Spare Tire Cover, Gray-Green Felt (RE) .	35.00/ea.
PK334D	1969-70	Spare Tire Cover, Black Felt (RE).....	35.00/ea.

JACK PACKS

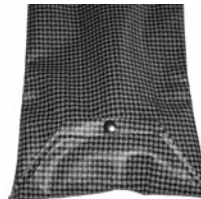

PK335A

Although never offered by Pontiac, the jack pack will help prevent scratching and marring of your trunk area. Large enough to store your jack and lug wrench. Available in the same colors as our trunk mats, side panels and spare tire covers.

PK335A	Jack Pack, Gray and Black Houndstooth (AP).....	\$12.00/ea.
PK335B	Jack Pack, Red and Black Houndstooth (AP).....	12.00/ea.
PK335C	Jack Pack, Red, Fawn and Black Herringbone (AP)	12.00/ea.
PK335D	Jack Pack, Red and Black Herringbone (AP)	12.00/ea.
PK335E	Jack Pack, Aqua and Black Herringbone (AP).....	12.00/ea.
PK335F	Jack Pack, Gator (AP).....	12.00/ea.
PK335G	Jack Pack, Gray and Black Herringbone (AP)	12.00/ea.

TRUNK DIVIDERS



PK336	1955-57	Trunk Divider- Star Chief - 2 Dr. HT (RE)	20.00/ea.
PK336A	1955-57	Trunk Divider- Star Chief w/Jute - 2 Dr. HT (RE).....	30.00/ea.
PK337	1955-57	Trunk Divider- Chieftain & Superchief 2 Dr. HT(RE).....	20.00/ea.

Add \$15.00 oversize fee to standard shipping for trunk dividers.

Trunk Divider Panels continued on next page.



Trunk Divider Panels continued.

PK337A	1955-57	Trunk Divider w/Jute - Chieftain & Superchief 2 Dr. HT (RE).....	\$30.00/ea.
PK338	1955-57	Trunk Divider - Sedan 4 Dr. HT (RE)	20.00/ea.
PK338A	1955-57	Trunk Divider w/Jute - Sedan 4 Dr.HT (RE)	30.00/ea.
PK339	1958	Trunk Divider - Bonneville 2 Dr. HT, Crosshatch(RE).....	Inquire
PK339A	1958	Trunk Divider w/Jute - Bonneville 2 Dr. HT, Crosshatch (RE).....	Inquire
PK339B	1958	Trunk Divider - Bonneville 2 Dr. HT, Plain Cardboard (RE).....	19.00/ea.
PK339C	1958	Trunk Divider w/Jute - Bonneville 2 Dr. HT, Plain Cardboard (RE).....	29.00/ea.

PK339 and PK339A are not available at this time. PK339B and PK339C offer an alternative utilizing plain black cardboard.

PK340	1959	Trunk Divider - Catalina 2 Dr.HT - GHT(RE).....	26.00/ea.
PK340A	1959	Trunk Divider w/Jute - Catalina 2 Dr. HT - GHT (RE).....	36.00/ea.
PK340C	1959	Trunk Divider - Bonneville 2 Dr. HT -GHT (RE).....	26.00/ea.
PK340D	1959	Trunk Divider w/Jute - Bonneville 2 Dr. HT - GHT (RE).....	36.00/ea.
PK340F	1959	Trunk Divider- All Sedan & 4 Dr. HT -GHT(RE).....	26.00/ea.
PK340G	1959	Trunk Divider w/Jute - All Sedan & 4 Dr. HT - GHT (RE).....	36.00/ea.

Note: All 1959 trunk dividers come printed with the gray and black houndstooth pattern. All 1960 trunk dividers come printed with red and black houndstooth pattern. 1961 and newer dividers are black cardboard.

PK341	1960	Trunk Divider - Catalina 2 Dr. HT - RHT (RE).....	26.00/ea.
PK341A	1960	Trunk Divider w/Jute - Catalina 2 Dr. HT - RHT (RE).....	36.00/ea.
PK341C	1960	Trunk Divider - Bonneville 2 Dr. HT - RHT (RE).....	26.00/ea.
PK341D	1960	Trunk Divider w/Jute - Bonneville 2 Dr. HT - RHT (RE).....	36.00/ea.
PK341F	1960	Trunk Divider - All Sedan & 4 Dr. HT - RHT (RE).....	26.00/ea.
PK341G	1960	Trunk Divider w/Jute - All Sedan & 4 Dr. HT - RHT (RE).....	36.00/ea.
PK342	1961	Trunk Divider - HT(RE).....	19.00/ea.
PK342A	1961	Trunk Divider w/Jute - HT (RE).....	29.00/ea.
PK342F	1961-64	Trunk Divider - All Sedan & '62-'64 4 Dr. HT (RE).....	19.00/ea.
PK342G	1961-64	Trunk Divider w/Jute - All Sedan & '62-'64 4 Dr. HT (RE).....	29.00/ea.
PK343	1962-64	Trunk Divide - 2 Dr. HT (RE)	20.00/ea.
PK343A	1962-64	Trunk Divider w/Jute - 2 Dr. HT(RE).....	32.00/ea.
PK344	1965-66	Trunk Divider - All exc. CVT (RE)	19.00/ea.
PK344A	1965-66	Trunk Divider w/Jute - All exc. CVT (RE)	29.00/ea.
PK345	1967-68	Trunk Divider - All exc. CVT (RE)	19.00/ea.
PK345A	1967-68	Trunk Divider w/Jute - All exc. CVT (RE)	29.00/ea.

Note: These panel boards were factory equipment between the rear seat and trunk in hardtops and sedans. This divider gives your trunk that final touch.

Comments: Excellent.

Add \$15.00 oversize fee to standard shipping for trunk dividers.



TRUNK WEATHERSTRIP



PK350	3M Black Weatherstrip Adhesive (AP) ..	9.00/ea.
PV877	BlackWeatherstrip Adhesive (GM)	12.00/ea.



PK378

PK360	1955-56	Trunk Weatherstrip - All (RE)	\$19.00/ea.
PK362	1957	Trunk Weatherstrip - Chieftain & Superchief (RE).....	28.00/ea.
PK363	1957	Trunk Weatherstrip - Star Chief & Bonneville(RE)	28.00/ea.
PK364	1958	Trunk Weatherstrip (RE)	22.00/ea.
PK366	1959-60	Trunk Weatherstrip - Catalina & Ventura (RE).....	22.00/ea.
PK367	1959-60	Trunk Weatherstrip - Star Chief & Bonneville (RE)	22.00/ea.
PK369	1961-62	Trunk Weatherstrip - Catalina, GP & Ventura.....	22.00/ea.
PK370	1961-62	Trunk Weatherstrip - Star Chief & Bonneville (RE)	22.00/ea.
PK373	1963-64	Trunk Weatherstrip - Catalina, GP & Ventura (RE).....	22.00/ea.
PK374	1963-64	Trunk Weatherstrip - Star Chief & Bonneville (RE)	22.00/ea.
PK378	1965-70	Trunk Weatherstrip - Catalina, Ventura & '65-'68 GP (RE)	22.00/ea.
PK379	1965-70	Trunk Weatherstrip - Star Chief & Bonneville & Executive (RE).....	22.00/ea.
PK383	1969-72	Trunk Weatherstrip - GP (RE).....	20.00/ea.
PK384	1971-76	Trunk Weatherstrip - FS (RE).....	22.00/ea.
PK385	1973-77	Trunk Weatherstrip - GP (RE).....	22.00/ea.

All above trunk weatherstrips come from what we feel is the best weatherstrip on the market. We have studied samples from four manufacturers of reproduction extruded trunk weatherstrip. The product we've chosen to handle illustrates the best shape, texture, cell structure, and density.

Comments: Very good. More costly than some but the best extruded product on the market.

PK387	1969-72	Trunk Weatherstrip - Skin Coated Latex - GP.....	72.00/ea.
--------------	---------	---	-----------

This is the original GM style weatherstrip (the finest available).

TRUNK PAINT & CLEAR COAT

Aerosol paints cannot be shipped by air or outside the Continental United States.



PK400	Trunk Spatter Paint, Grey & White 14 oz. Aerosol Can (GM).....	15.00/ea.
PK401	Trunk Spatter Paint, Black & Aqua 14 oz. Aerosol Can (GM).....	15.00/ea.

This is GM's own trunk paint. Afterproduct spatter paint contains approximately 50% water which usually runs when the trunk area sweats. GM paint contains 30% and is far superior.

Comments: None of the products available is an exact match with the original. This is not perfect but the best we've seen in paint of this quality.

Note: Occasionally customers that order PK401 feel they have received PK400. As far as color goes, the grey in PK400 is very light, similar to concrete. The black in PK401 is actually a charcoal shade while the spatter is a very light aqua (at times the spatter almost appears white).

3 cans required for most trunks.

Trunk Spatter Paints continue on next page.

TRUNK COMPONENTS

Trunk Spatter Paint continued.



PK402



PK403



PK405

- PK402** Trunk Spatter Paint Grey & White
12 oz. aerosol can (AP)..... \$10.00/ea.
- PK403** Trunk Spatter Paint Black & Aqua
12 oz. aerosol can (AP)..... 10.00/ea.

We have found the Eastwood afterproduct brand spatter paint to be the best of the aftermarket paints. Although not an exact match to original it is the closest we've seen and very acceptable. Being water soluble, we strongly suggest finishing the trunk with PK405 clearcoat.

3 or 4 cans required for most trunks.

- PK405** Trunk Spatter Paint, Clear Coat (AP)..... 7.50/ea.

We highly recommend this product because when the trunk area sweats the spatter paint tends to run. 2 cans required for most trunks.

 Aerosol paints cannot be shipped by air or outside the Continental United States.

TRUNK LAMP KIT



PK410

- PK410** 1964-68 Trunk Lamp Kit (RE) 37.00/ea.

This is a reproduction of the accessory option available for '64-'68 Pontiacs. Many customers have used this on earlier cars by adapting the harness. PK410 is mercury switch activated.

- PK411** 1969-72 Trunk Lamp Kit - Coupe (RE) 69.00ea.
- PK411C** 1969-72 Trunk Lamp Kit - Convertible (RE)..... 69.00ea.

This reproduction lamp kit comes with the wiring harness and bulb.

TRUNK COMPONENTS

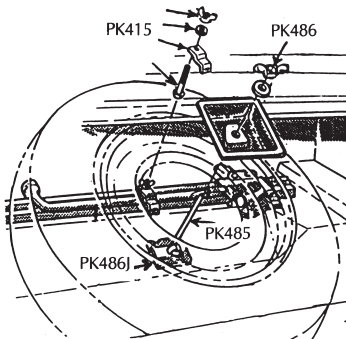

- PK415** 1965-66 Jack Hold-Down Assembly - HT (RE) ... 13.00/asm.

This highly sought-after bracket is usually missing. The assembly comes complete with bolt, bracket, washer, and wing nut. Excellent detail item. **Handle not included.**



PK424



PK460

- PK420** 1955-57 Trunk Bumper, Lower (RE) \$2.50/ea.
- PK422** 1955-57 Trunk Bumper, Upper (RE) 2.50/ea.
- PK424** 1958-66 Trunk Bumper (RE) 2.00/ea.
- PK440** 1967-68 Trunk Bumper (RE) 1.50/ea.
- PK441** 1969-76 Trunk Bumper - FS (RE) 1.50/ea.
- PK442** 1969-77 Trunk Bumper - GP (RE) 1.50/ea.
- PK460** 1969-77 Jack Handle - GP (GM) 25.00/ea.
- PK461** 1971-76 Jack Handle - FS (GM) Disc.
- PK461K** 1964-72 Rubber Jack Sleeve (GM) 16.00/ea.

Note: This rubber sleeve holds the jack handle to the jack stand for storage.

- PK461KC** 1964-72 Rubber Jack Sleeve (RE) 8.00/ea.

PK461KC is a reproduction alternative to PK461K.

- PK465** 1965-70 Blue Paint (For Jack Handle and Base) 11 oz. Aerosol Can (AP) 8.50/ea.

- PK468** 1955 Trunk Wiring Harness Grommet (RE).... 6.00/ea.

Requires 2. Fits 7/8" hole w/3/16" center hole.



PK486



PK486D

- PK470** 1956 Rear Body Bolt Access Plug (RE)..... 5.50/pr.
- PK473** 1955-57 1" Trunk Access Plug (RE) 1.50/ea.
- PK473A** 1955-57 1 3/8" Trunk Access Plug (RE)..... 3.00/ea.

Note: Fits 1 3/8" hole with overall diameter of 2 1/4".

- PK474** 1955-57 1" Spare Tire Well Plug (RE) 1.50/ea.

- PK480** 1959-70 Rubber 1" Trunk Plug (RE) 1.50/ea.

- PK481** 1959-70 Rubber 3/4" Trunk Plug (GM) 2.50/ea.

- PK485** 1959-77 Spare Tire Hold-Down Rod - All (GM).. 7.50/ea.

- PK486** 1959-77 Spare Tire Hold-Down Nut - All (GM).. 5.00/ea.

- PK486j** 1959-77 Spare Tire Anchor Bracket (RE)..... 6.00/ea.

Note: The PK485 Hold-Down Rod loops through this bracket holding the rod to the trunk floor.

- PK486D** 1959-77 Spare Tire Hold Down Washer (RE) 4.50/ea.

This is the unique spare tire hold-down washer which in most cases has been missing since the first tire change. Due to its dimensions, it is a one of a kind washer. Addition of this washer could be an easy points saver at the shows.



PK487

- PK487** 1960-68 Eight-Lug Hold-Down Plate (RE) 35.00/ea.

Note: This plate is manufactured like original. It is made from the same thickness stock, has the correct crimped notches, and is stamped to have the original convex shape. The plate was used not only to anchor the eight-lug spare in the trunk, but also to hold the rim securely when mounting and dismounting tire.

Quality: Excellent.



PK495

- PK495** 1967-77 Automatic Trunk Release Switch (GM) . 10.00/ea.

TRUNK COMPONENTS



	PK497J		PK497K	
PK497J	1966	Vacuum Check Valve for Vacuum Operated Automatic Trunk Release(GM)	\$11.00/ea.	
PK497K	1966	Vacuum Reserve Tank w/Vacuum Operated Automatic Trunk Release (AP)	51.00/ea.	

This canister serves as a replacement. Dimensions are not the same as original.

DECKLID LATCH & SHAFT



PK500

PK500	1959-70	Deck Lid Lock Latch - All (RE)	26.00/ea.
PK501	1971-77	Deck Lid Lock Latch - All (RE)	33.00/ea.



PK510

PK510	1955-66	Deck Lid Lock Shaft (GM)	3.50/ea.
--------------	---------	--------------------------	----------

DECK LID KEY BLANKS



PK525



PK528

PK525	1955-66	Deck Lid Key Blank (NOS)	3.50/ea.
PK526	1967	Deck Lid Key Blank (B) (NOS)	3.50/ea.
PK527	1968	Deck Lid Key Blank (D) (NOS)	3.50/ea.

Note: PK525, PK526, and PK527 have the original pear type head design. PK525 has knockout removed while PK526 and PK527 have the knockout in place.

PK528	1968	Deck Lid Key Blank (D) (GM)	2.00/ea.
--------------	------	-----------------------------	----------

Note: PK528 has an oval style head without knockout like the following later-style keys.

PK529	1969	Deck Lid Key Blank (H) (GM)	2.00/ea.
PK530	1970	Deck Lid Key Blank (K) (GM)	2.00/ea.
PK531	1971	Deck Lid Key Blank (B) (GM)	2.00/ea.
PK532	1972	Deck Lid Key Blank (D) (GM)	2.00/ea.
PK533	1973	Deck Lid Key Blank (H) (GM)	2.00/ea.
PK534	1974	Deck Lid Key Blank (K) (GM)	2.00/ea.
PK535	1975	Deck Lid Key Blank (B) (GM)	2.00/ea.
PK536	1976	Deck Lid Key Blank (D) (GM)	2.00/ea.
PK537	1977	Deck Lid Key Blank (H) (GM)	2.00/ea.

DECK LID LOCK ASSEMBLIES & COMPONENTS



PK551A



PK561

PK550	1955-58	Deck Lid Lock Assembly w/Late-Style Key (RE)	\$14.00/ea.
PK550A	1955-58	Deck Lid Lock Assembly w/Original-Style Key (RE)	17.00/ea.
PK551	1959	Deck Lid Lock Assembly w/Late-Style Key (RE)	14.00/ea.
PK551A	1959	Deck Lid Lock Assembly w/Original-Style Key (RE)	17.00/ea.
PK552	1960	Deck Lid Lock Assembly w/Late-Style Key (RE)	14.00/ea.
PK552A	1960	Deck Lid Lock Assembly w/Original-Style Key (RE)	17.00/ea.
PK553	1961-62	Deck Lid Lock Assembly w/Late-Style Key (RE)	14.00/ea.
PK553A	1961-62	Deck Lid Lock Assembly w/Original-Style Key (RE)	17.00/ea.
PK553B	1962	Deck Lid Lock Assembly, Grand Prix w/Late-Style Key (NOS)	18.00/ea.
PK553D	1962	Deck Lid Lock Assembly, Grand Prix w/Original-Style Key (RE)	28.00/ea.
PK554	1963-64	Deck Lid Lock Assembly, Exc GP w/Late-Style Key (RE)	14.00/ea.
PK554A	1963-64	Deck Lid Lock Assembly, Exc. GP w/Original-Style Key (RE)	17.00/ea.
PK555	1965	Deck Lid Lock Assembly w/Late-Style Key - All exc. GP (RE)	14.00/ea.
PK555A	1965	Deck Lid Lock Assembly w/Original-Style Key - All exc. GP (RE)	17.00/ea.
PK555C	1966	Deck Lid Lock Assembly w/Late-Style Key - All exc. GP (RE)	14.00/ea.
PK555D	1966	Deck Lid Lock Assembly w/Original-Style Key - All exc. GP (RE)	17.00/ea.
PK556	1967	Deck Lid Lock Assembly w/Late-Style Key - All exc. Bonneville & GP (RE)	13.00/ea.
PK556A	1967	Deck Lid Lock Assembly w/Original-Style Key - All exc. Bonneville & GP (RE)	19.00/ea.
PK557	1967	Deck Lid Lock Assembly w/Late-Style Key - Bonneville & GP (RE)	18.00/ea.
PK557A	1967	Deck Lid Lock Assembly w/Original-Style Key - Bonneville & GP (RE)	28.00/ea.
PK558	1968	Deck Lid Lock Assembly w/Late-Style Key (RE)	14.00/ea.
PK558A	1968	Deck Lid Lock Assembly w/Original-Style Key (RE)	17.00/ea.
PK559	1969-77	Deck Lid Lock Assembly w/Original-Style Key - FS & GP (RE)	14.00/ea.
PK561	1955-77	Deck Lid Lock Gasket (RE)	1.50/ea.

See The Miscellaneous Section for complete lock sets.



PK570



PK575

PK570	1968-72	Trunk Lock Retainer Gasket - GP (RE)	3.00/ea.
PK570	1969-70	Trunk Lock Retainer Gasket - FS (RE)	3.00/ea.
PK571	1971-76	Trunk Lock Retainer Gasket - FS (GM)	7.00/ea.
PK571	1973-77	Trunk Lock Retainer Gasket - GP (GM)	7.00/ea.
PK571C	1971-76	Trunk Lock Retainer Gasket - FS (RE)	4.00/ea.
PK571C	1973-77	Trunk Lock Retainer Gasket - GP (RE)	4.00/ea.

These are the gaskets that seal the lock retainer to the deck lid.

PK571C is a less expensive alternative to PK571.

PK575	1955-57	Trunk Lock Retainer - All exc. SW (RE)	8.00/ea.
--------------	---------	--	----------



www.takeakidtoacarshow.com

1969-72 GRAND PRIX TRUNK SHEETMETAL

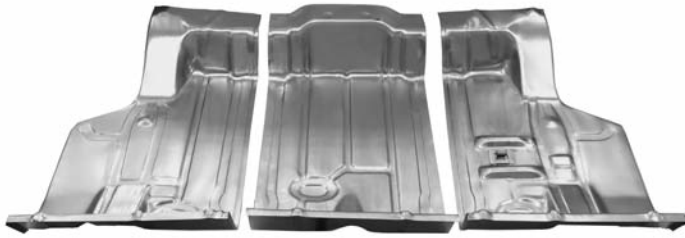

- PK673** 1969-72 Full Trunk Floor, Body Braces, and Fuel Tank Braces - GP (RE) \$385.00/set
- PK674** 1969-72 Trunk Floor, LH w/Body Brace - GP (RE) 119.00/ea.
- PK675** 1969-72 Trunk Floor, RH w/Body Brace - GP (RE) 119.00/ea.
- PK676** 1969-72 Trunk Floor Center - GP (RE) 75.00/ea.
- PK677** 1969-72 Fuel Tank Braces - GP (RE) 35.00/ea.
- PK678** 1969-72 Body Brace, LH - GP (RE)..... 55.00/ea.
- PK679** 1969-72 Body Brace, RH - GP (RE) 55.00/ea.
- PK680L** 1969-72 Inner Wheelwell Repair Kit, LH -GP (RE) 59.00/ea.
- PK680R** 1969-72 Inner Wheelwell Repair Kit, RH -GP (RE) 59.00/ea.

For complete inner wheelhouse panels, please refer to the Rear 1/4 Trim section.

It is recommended that the installer fully investigate the extent of the trunk rust. In almost all cases the body brace is needed (body braces are included in the price of the LH and RH trunk floor sections). Other companies may sell just the floor pan at reduced prices, but it is seldom sufficient.

Note: The rear edge of these floor pans will need to be trimmed for proper fit on Grand Prix.

Add \$35.00 oversize fee to standard shipping for PK673 through PK676 and \$10.00 for PK678 through PK680R.



1973-77 GRAND PRIX TRUNK SHEETMETAL

- PK715** 1973-77 Trunk Floor, LH - GP (RE) 148.00/ea.
- PK716** 1973-77 Trunk Floor, Center - GP (RE)..... 148.00/ea.
- PK717** 1973-77 Trunk Floor, RH - GP (RE)..... 148.00/ea.

Add \$35.00 oversize fee to standard shipping for PK715 through PK717.



- PK718** 1973-77 Trunk Floor Brace, LH - GP (RE) 80.00/ea.
- PK719** 1973-77 Trunk Floor Brace, RH - GP (RE) 80.00/ea.
- PK720** 1973-77 Gas Tank Brace, LH or RH - GP (RE)..... 95.00/ea.

2 required per car.

1961-1964 TRUNK MOUNTS



- PK650** 1961-64 Trunk Mounts (RE) \$120.00/pr.

TRUNK LIP PANELS



PK730

- PK730** 1958 Trunk Opening Bottom Lip Patch Panels (RE) 109.00/pr.

These patch panels will cure the commonly rusted area on 58 trunk openings. The bottom lip comes in two pieces (upper and lower) ready to replace the weatherstrip channel and dropleg from weatherstrip channel to trunk floor.

DRAIN PLUGS & SEAM SEALER



PK749

- PK749** Trunk Floor Drain Plug, Steel (RE) 4.50/ea.

This is the correct-style plug with two notches and is secured to the floor by two screws.



PK750

- PK750** 1961-77 Floor Drain Plug (RE) 4.50/ea.

This is the steel drain plug found in both the body and trunk floors.



PK770

- PK770** Seam Sealer, Tan (AP) 15.00/tube

DECKLID



- PK488R** 1969-70 Deck Lid - GP 419.00/ea.

This new deck lid for 1969-70 Grand Prix looks excellent and fits very well.

PK448R is drop-shipped directly from the manufacturer and must ship truck freight to a commercial address. Please inquire for freight charges. Note: \$20.00 box fee.



REAR END TRIM

EMBLEMS



PL102

PL102 1956 Deck Lid Star - Star Chief (RE) \$23.00/ea.
Requires 3 pieces.

PL103J 1955-57 Safari Deluxe "Pontiac" Letters (RE)..... 79.00/set
PL103K 1955-57 Safari Standard "Pontiac" Letters (RE) ... 79.00/set



PL104

PL104 1958 "Fuel Injection" Rear Deck Lid Plate (RE) Disc.



PL104B

PL104B 1958 Bonneville Rear Light Paint Dividers, Set of 4 (RE)..... 62.00/set
PL104B fits Bonneville only.



PL104D 1958 "Bonneville" Trunk Letters (RE)..... 159.00/set



PL105

PL105 1959 "Pontiac" Tail Panel Letters (RE) 115.00/set



PL110

PL110 1961 Rear Deck Lid Arrowhead (APE) 33.00/ea.



PL110J 1961 "Bonneville" Tail Panel Letters -Gold (RE)..... \$195.00/set



PL111

PL111 1962 Rear Deck Lid Arrowhead (APE) 33.00/ea.



PL111D

PL111D 1962 "Grand Prix" Rear End Panel Emblem (RE) Disc.
Note: This emblem is a little thicker than original.

PL112 1963 Rear Deck Lid Arrowhead - Exc. GP (APE) 33.00/ea.
PL112A 1963 Rear Deck Lid Arrowhead - GP (RE) 37.00/ea.



PL113

PL113 1963 Rear Deck Lid Plate - GP (RE)..... 37.00/ea.
PL114 1964 Rear Deck Lid Arrowhead (APE) 33.00/ea.



PL114D 1964 "Grand Prix" Deck Lid Letters, 9 pcs. (RE) 75.00/set



PL114Y

PL114Y 1965 "GP" Deck Lid Emblem (RE) 37.00/ea.



PL115

PL115 1965 Rear Deck Lid Arrowhead (APE) 33.00/ea.
PL116 1966 Rear Deck Lid Arrowhead (APE) 33.00/ea.



PL116A 1966 "Pontiac" Tail Panel Letters - Catalina & Starchief (RE) \$59.00/set

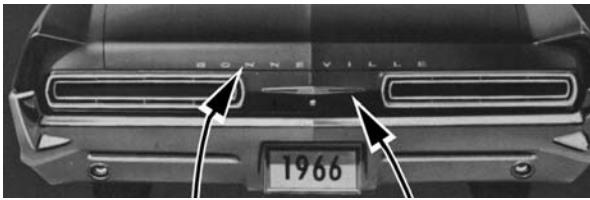

PL116B 1966 "Bonneville" Deck Lid Letters, 10 pcs. (RE) 113.00/set
 PL116BA 1966 Bonneville Tail Panel Emblem (RE)..... Disc.



PL116C 1966 "Grand Prix" Deck Lid Letters (RE)..... 71.00/ea.
 PL116J 1967 Rear Deck Lid Arrowhead - Catalina & 2+2 (RE) 31.00/ea.
 PL116K 1967 Rear Deck Lid Arrowhead - All exc. Catalina & 2+2 (RE)..... 32.00/ea.



PL116M 1967 "Bonneville" Taillight Panel Emblem (RE) 29.00/ea.



PL117 1965-66 "2+2" Rear Deck Lid Emblem (RE) 26.00/ea.
 PL118 1967 "2+2" Rear Deck Lid Emblem (RE) 26.00/ea.



PL118D 1967-68 "GP" Rear Deck Lid Emblem (RE) 28.00/ea.



PL118F 1968 "Pontiac" Deck Lid Letters - GP (RE)..... 45.00/set



PL122 1969 "Bonneville" SW Tailgate Letters, 10 Piece Set (RE) 105.00/set

Note: These letters may be used for 1968 also. Only the letter "B" differs slightly; however, with slight modifications it will work.



PL123J 1969-70 "Grand Prix" Deck Lid Letters, 9 piece set (RE)..... \$84.00/set



PL123M 1970 "Model J" Deck Lid Emblem - GP (RE).. 22.00/ea.
 PL123N 1970 "Model SJ" Deck Lid Emblem - GP (RE) 23.00/ea.



PL125 1971-72 "Grand Prix" Deck Lid Emblem (RE) 26.00/ea.
 PL128 1973-77 "Grand Prix" Deck Lid Emblem (RE)..... Disc.



PL134 1976-77 Deck Lid Lock Dust Cover Lucite (GM) Disc.



PL135 Hurst Equipped Emblem (AP) 30.00/ea.
 PL135 is a low pressure casting with 3 pins that require drilling holes for mounting.
 PL135A Hurst Equipped Emblem (AP) 16.00/ea.
 This is a Hurst® manufactured plastic adhesive-backed alternative to PL135. Quality is very good.



TAKE A
 Kid Car
 TO A Show

R E A R E N D T R I M

TAILGATE COMPONENTS



PL190

- PL190** 1955-57 Lower Tailgate Cable - Safari (RE) \$25.00/ea.
- PL190B** 1955-57 Lower Tailgate Cable - SW (RE) 25.00/ea.
- PL190D** 1955-57 Lower Tailgate Cable Reel (RE)..... 46.00/ea.

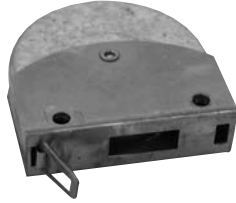

PL190D\$



PL200AG

- PL200AF** 1955-57 Tailgate Bar Clip (RE) \$3.50/ea.
- PL200AG** 1955-57 Tailgate Bar Clip Set, 33 pcs. (RE) 79.00/ea.
- PL201** 1955-57 Lower Tailgate Weatherstrip - Safari (RE) 55.00/ea.
- PL202** 1955-57 Upper Tailgate Weatherstrip - Safari (RE) 25.00/ea.
- PL203** 1955-57 Lower Tailgate Weatherstrip - SW (RE).. 55.00/ea.
- PL204** 1955-57 Upper Tailgate Weatherstrip - SW (RE).. 55.00/ea.



PL193

- PL193** 1955-57 Upper Tailgate Support Arm Rebuild Kit - Safari & SW (RE)..... 15.00/kit
- PL195** 1955-57 Inner Lower Tailgate Hinge Covers - Safari (RE) Disc.
- PL195A** 1955-57 Inner Lower Tailgate Hinge Covers - SW (RE) Disc.

These covers are zinc-plated to resist rust and corrosion.



PL205

- PL205** 1955-57 Lower Tailgate Bumpers - Safari (RE)..... 5.50/pr.
- PL206** 1955-57 Lower Tailgate Bumpers - SW (RE) 4.50/ea.



PL208

- PL208** 1955-57 Upper Tailgate Tabs - Safari (RE) 14.00/pr.
- Note: These are located on the ends of the upper tailgate.*

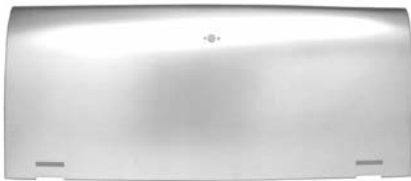

PL199R

- PL199R** 1955-57 Outer Tailgate Skin - Exc. Safari (RE) 259.00/ea.



PL199S

- PL199S** 1955-57 Outer Tailgate Skin - Safari (RE) 379.00/ea.



PL200

- PL200** 1955-57 Outer Tailgate Bar Set- Safari, 6 pcs. (RE) 389.00/set
- PL200A** Late 1955-57 Center Tailgate Bar Safari (RE)..... 177.00/ea.
- PL200AC** 1955-57 Center Tailgate Bar Handle - Safari (RE) 72.00/ea.



PL210G

- PL210** 1955-57 Lower Tailgate Hinge Screw Set - SW, 6 pcs. (RE) 5.00/set
- Contains enough screws to do one hinge.
- PL210D** 1955-57 Liftgate Inner Window Frame Screw Set - Safari (RE) 11.00/set
 - PL210G** 1955-57 Upper & Lower Tailgate Fastener Kit - Stainless Steel, 126 pcs. (RE)..... 22.00/set



PL211

- PL211** 1955-57 Tailgate Hinge Repair Kit (RE)..... 13.00/kit
- This contains 2 new pins and 4 bushings to refurbish your worn hinges.

R E A R E N D T R I M

EXHAUST HANGERS & CLAMPS



PL220DC

PL220C 1969-72 Muffler Hanger (dual exh.), LH - GP (RE) \$23.00/ea.

PL220D 1969-72 Muffler Hanger (dual exh.), RH - GP (RE) 23.00/ea.

PL220C & PL220D are very close to originals.

PL220DC 1969-72 Muffler Hangers (dual exh.), Pair - GP, Original Style (RE) 45.00/pr.

PL220DC combines the correct reproduction PL220C & PL220D.

PL220DS 1969-72 Muffler Hangers (dual exh.), Pair - GP, Stainless Steel (AP) 24.50/pr.

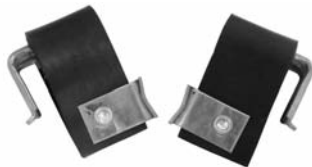

PL220FS

PL220F 1969-72 Tail Pipe Hangers (Rear) - GP (AP) Inquire

PL220FS 1969-72 Tail Pipe Hangers (Rear), Stainless Steel - GP (AP) 24.50/pr.

PL220F & PL220FS are similar to original. Originally, the pipe was positioned beside the bracket while, with these, the pipe is clamped below the bracket.

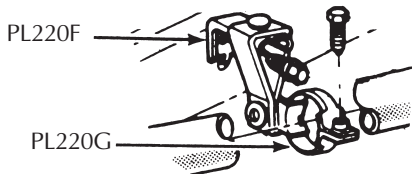

PL220G

PL220G Exhaust Band Clamp (Rear - 2" dia.)(APE) 13.00/pr.

PL220H Exhaust Band Clamp (Rear - 2 1/4" dia.)(APE)..... 13.00/pr.

These unique clamps were used on many Pontiacs with dual exhaust. Use with PL220F for final exhaust detailing.



PL220M



PL220N

PL220M 1966-73 Original GM Style Muffler Clamp, 2" (APE) 6.50/ea.

PL220N 1966-73 Original GM Style Muffler Clamp, 2 1/4" (APE) 6.50/ea.

For the serious restorer, these exact clamps with the circular style outer profile were reproduced using samples from low mileage original exhaust cars and NOS accessory exhaust extension kits from 1966.

Note: We are unsure about '64 and '65 cars, but believe these clamps were used and this style clamp was dropped in either 1974 or 1975.

TAILPIPE EXTENSIONS

These reproduction exhaust tips are original for GTO. Although not originally used on full-size Pontiacs, they are a nice addition to any exhaust system.



PL240

PL240 2" Exhaust Extensions, Pair - Stainless Steel (AP-APE) \$69.00/pr.

Quality: Excellent; High-grade stainless steel.



PL241

PL241 2 1/4" Exhaust Extensions, Pair - Chrome (AP-APE)..... 59.00/pr.

Quality: Excellent; triple-chrome plated.

PL242 2 1/2" Exhaust Extensions, Pair - Polished 304 Stainless Steel (AP) 65.00/pr.

Quality: Excellent.

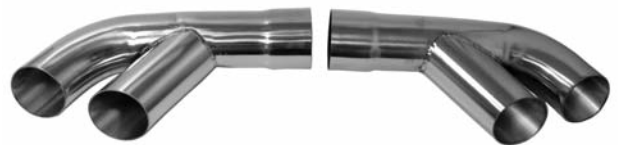

PL244

PL244 2 1/2" Exhaust Quarter - Exit Splitters, Pair - Polished 304 Stainless Steel (AP) 90.00/pr.



PL248

PL248 2 1/4" Exhaust Extensions, Pair - Chrome (APE) 62.00/pr.



PL249

PL249 2 1/4" Exhaust Rear Exit Splitters, Pair - Chrome (APE) 99.00/pr.

PL249A 2 1/2" Exhaust Rear Exit Splitters, Pair - Polished 304 Stainless Steel (AP) 65.00/pr.

PL249C 2 1/4" Chrome Exhaust Splitters & Hardware..... 165.00/ea.

R E A R E N D T R I M

TAILLAMP LENSES AND COMPONENTS



- | | | | |
|---------------|---------|--|-------------|
| | PL258 | PL258A | |
| PL258 | 1955-56 | Taillamp Lens - All exc. 870 & Star Chief Exc. SW (RE)..... | Inquire |
| PL258A | 1955-56 | Taillamp Lens Trim Ring - All 870 & Star Chief Exc. SW (RE)..... | \$24.00/pr. |
| PL258B | 1955-56 | Taillamp Lens w/Trim Ring - All 870 & Star Chief Exc. SW (RE)..... | Inquire |
- Note: PL258 and PL258A are nice reproductions. Lenses do not have GUIDE or guidex imprints. Trim ring must be epoxied onto lens to make deluxe lens. Ring will fit reproduction or original lenses.*
- | | | | |
|---------------|---------|---|----------|
| PL258C | 1955-56 | Taillamp Lens Gaskets, Pair (RE)..... | 6.00/pr. |
| PL258G | 1955-56 | Taillamp to Rear 1/4 Seal - Chieftain Wagons only (RE)..... | 4.00/pr. |



- | | | | |
|---------------|------|--|-------------|
| | | PL264 | |
| PL264 | 1960 | Taillamp Lens - Bonneville & Star Chief Exc. SW (RE)..... | \$17.00/ea. |
| | | Requires 4. | |
| PL264B | 1960 | Taillamp Lens - All Exc. Bonneville & Star Chief (RE)..... | 17.00/ea. |
| | | Requires 4. | |



- | | | | | |
|----------------|------|--|---------|-----------|
| | | PL265 | PL265AL | |
| PL265 | 1961 | Taillamp Lens - Catalina & Ventura w/ Trim, Exc. SW (RE) | | 59.00/pr. |
| PL265AL | 1961 | Taillamp Lens - Bonneville & Starchief Exc. SW, LH (RE) | | 17.00/ea. |
| | | Requires 3 pieces per car. | | |
| PL265AR | 1961 | Taillamp Lens - Bonneville & Starchief Exc. SW, RH (RE) | | 17.00/ea. |
| | | Requires 3 pieces per car. | | |



- | | | | | |
|---------------|------|---|--------|-----------|
| | | PL260 | PL260A | |
| PL260 | 1957 | Taillamp Lens - Bonneville & Starchief (RE) | | Disc. |
| PL260A | 1957 | Taillamp Lens Gaskets (RE) | | 13.00/pr. |



- | | | | | |
|----------------|------|---|--------|-----------|
| | | PL262 | PL262A | |
| PL262 | 1958 | Taillamp Lens w/Chrome Trim Bonneville & Starchief Exc. SW (RE) | | Disc. |
| | | Requires 4 pieces per car. | | |
| PL262AA | 1958 | Taillamp Lens w/o Chrome Trim Chieftain and Superchief Exc. SW (RE) . | | 17.00/ea. |
| | | Requires 4 pieces per car. | | |
| PL262A | 1958 | Taillamp Lens Gasket Set (4 pcs.) (RE) ... | | 16.00/set |
| PL262AB | 1958 | Taillamp Lens Screws (AP) | | Inquire |



- | | | | | |
|--------------|------|---|-------|-----------|
| | | PL266 | PL267 | |
| PL266 | 1962 | Taillamp Lens - Catalina Exc. SW w/ Trim (RE) | | 40.00/pr. |
| PL267 | 1963 | Taillamp Lens - All Exc. GP & SW (RE).. | | 40.00/pr. |



- | | | | |
|---------------|------|---|----------|
| | | PL267J | |
| PL267J | 1963 | Taillamp Assembly to Body Seal - Exc. GP (RE) | 4.50/pr. |
| PL267M | 1963 | Taillamp Lens Gasket - Exc. GP (RE) | 6.50/pr. |



- | | | | |
|--------------|------|--|-----------|
| | | PL263 | |
| PL263 | 1959 | Taillamp Lens - Catalina Exc. SW (RE) .. | 40.00/pr. |



- | | | | | |
|---------------|------|---|--------|-----------|
| | | PL267P | PL267X | |
| PL267P | 1964 | Taillamp Lens - Catalina & Starchief Exc. SW (RE) | | 49.00/pr. |
| PL267X | 1968 | Taillamp Lens Gaskets - Bonneville Exc. SW (RE) | | 30.00/pr. |

REAR END TRIM

BACK UP LENSES & GASKETS



PL275A

- | | | |
|---------------|--|------------|
| PL275 | 1955-56 Back-Up Lenses, Pair (RE)..... | Disc. |
| PL275A | 1955-56 Back-up Lamp Gaskets, Pair (RE)..... | \$6.00/pr. |
| PL275B | 1955-56 Back-up Lamp Lens - SW Exc. Safari,
LH or RH (RE) | 27.00/ea. |
| PL275C | 1955-56 Back-Up Lens Gaskets - SW, Pair (RE)... | 6.00/pr. |



PL280



PL280A



- | | | |
|---------------|---|-------------|
| PL280 | 1964-66 Back-Up Lenses - Exc. '64 GP (APE)..... | \$20.00/pr. |
| PL280A | 1964-66 Back-Up Lens Gaskets - Exc. '64 GP
(APE) | 7.00/pr. |



PL276



PL276A

- | | | |
|---------------|--|-----------|
| PL276 | 1957 Back-Up Lenses - All Exc.
SW, Pair (RE)..... | 49.00/pr. |
| PL276A | 1957 Back-Up Lens Gaskets - All Exc.
SW, Pair (RE)..... | 9.00/pr. |



PL276B

- | | | |
|---------------|---|-----------|
| PL276B | 1957 Back-Up Lens - SW (RE)..... | 55.00/ea. |
| PL276C | 1957 Back-Up Lens Gaskets - SW Exc. Safari,
Pair (RE)..... | Disc. |

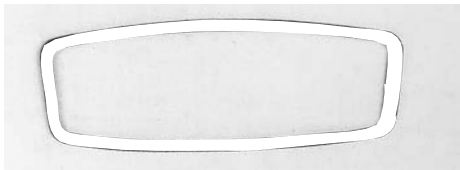

PL276E

- | | | |
|---------------|--------------------------------------|----------|
| PL276E | 1958 Back-Up Lens Gaskets (APE)..... | 8.50/pr. |
|---------------|--------------------------------------|----------|



PL276J



PL276M

- | | | |
|---------------|--|-----------|
| PL276J | 1959 Back-Up Lenses (RE) | 33.00/pr. |
| PL276M | 1960 Back-Up Lenses - All Exc. SW (RE) | 49.00/pr. |

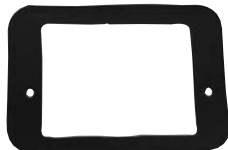

PL276R

- | | | |
|---------------|--|-----------|
| PL276R | 1961 Back-Up Lens Gaskets - Star Chief (RE). | 16.00/pr. |
|---------------|--|-----------|



PL280C

- | | | |
|---------------|---|-----------|
| PL280C | 1964-66 Back-Up Lamp Housing - Exc. '64
GP (RE)..... | 34.00/ea. |
| PL280D | 1964-66 Back-Up Lamp Kit - Exc. '64
GP (RE)..... | 49.00/kit |

PL280D includes housing, lens, lens gasket, bulb and screws. 2 required per car.

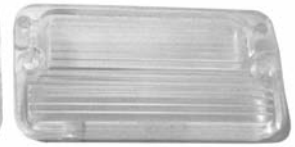
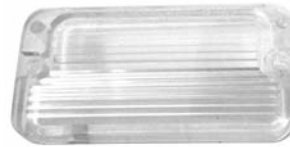

PL281

- | | | |
|---------------|--|------------|
| PL281H | 1967 Back-Up Light Assembly (RE)..... | 115.00/set |
| PL281H | 1968 Back-Up Light Assembly - SW Only (RE) | 115.00/set |

PL281H includes housings, lenses, lens gaskets, bulb and screws.

- | | | |
|--------------|--|-----------|
| PL281 | 1967 Back-Up Lenses (APE) | 27.00/pr. |
| PL281 | 1968 Back-Up Lenses- SW Only (APE) | 27.00/pr. |



PL281A

- | | | |
|---------------|--|----------|
| PL281A | 1967-68 Back-Up Lens Gaskets for PL281 (APE) | 6.50/ea. |
| PL290 | 1961-68 Back-Up Lens Screw (APE) | 2.00/ea. |

This is the special long-shanked screw used exclusively for Pontiac back-up lenses.



PL291

- | | | |
|---------------|--|-----------|
| PL291 | 1967 Back-Up Lamp Housing (RE) | 39.00/ea. |
| PL291G | 1968 Back-Up Lamp Housing,- SW Only (RE) | 39.00/ea. |

PL291 & PL291G include the socket & wire assembly.

R E A R E N D T R I M

TAILLIGHT BEZEL GASKETS

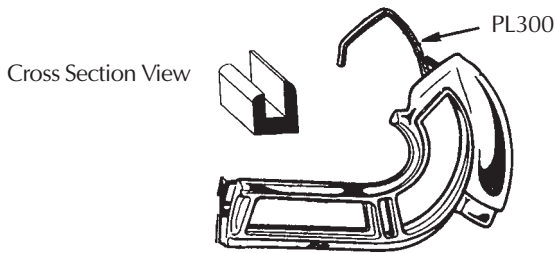

PL300 Taillight Bezel Gaskets (APE)..... \$1.50/ft.
Applications vary. Compare cross section view to original before ordering.



PL326 1965 Fuel Tank Vent Tube Kit (RE) \$17.00/kit
PL327 1966 Fuel Tank Vent Tube Kit (RE) 25.00/kit
PL328 1966-67/69-70 Fuel Tank Vent Tube Grommet (RE) .. 6.00/ea.

Reproductions of the comonly rotted line that connects to the filler neck vent.

Quality: Very Good.

FUEL TANKS & INSULATION



PL316 1969-70 Fuel Tank w/o Filler Neck- GP
Exc. EES of Calif. (RE)..... 206.00/ea.

Note: This reproduction tank comes without a sending unit and filler neck. You must use your original filler neck. New sending units, seals, and retainers are available on the next page.

Add \$35.00 oversize fee to standard shipping for gas tanks w/o filler necks.



PL317 1969-70 Fuel Tank w/Filler Neck - GP
Exc. EES of Calif. (RE)..... 209.00/ea.
PL319 1973 Fuel Tank w/ Filler Neck - GP (RE)..... 369.00/ea.
PL320 1974 Fuel Tank w/ Filler Neck - GP (RE)..... 369.00/ea.
PL321 1975-77 Fuel Tank w/ Filler Neck - GP (RE)..... 369.00/ea.

PL319 through PL321 are stamped with all the correct contours and have the same galvanized plating as original. Quality is considered to be excellent.

Note 1: Fuel tank capacities are to OEM specifications

There is an additional \$85.00 fee for shipping gas tanks with filler necks. We can remove the neck and ship it with the tank. The charge for this service and the additional shipping is \$45.00.



PL325 1961-67 Fuel Tank Insulation (AP) 24.00/ea.
25" L x 22"W x 3/16" thick.
PL325A 1968-77 Fuel Tank Insulation (AP) 24.00/ea.
35"L x 22 7/16"W x 3/16" thick.

FUEL GAUGE SENDING UNITS & RETAINERS



PL329A 1961-64 Fuel Gage Sending Unit, 3/8" Inlet
- All Exc. SW (RE) 79.00/ea.

PL329A does not have a vapor return. Includes the sock filter and seal.

PL329B 1961-64 Fuel Gage Sending Unit, 3/8" Inlet
- All Exc. SW (RE) 89.00/ea.

PL329B has a 1/4" a vapor return. Includes the sock filter and seal.

PL329F 1965-66 Fuel Gage Sending Unit, 3/8" Inlet
- All Exc. SW (RE) 50.00/ea.

PL329F does not have a vapor return. Includes the sock filter and seal.

PL330 1969-70 Fuel Gauge Sending Unit - GP (GM) Disc.

Note: This fits '70 GPs w/o EES except the 3/8" and 1/4" lines are reversed from the original design.

Note: Fuel gauge sending units do not come with locking retainers. Please order below.

PL330F 1969-70 Fuel Gauge Sending Unit - GP (RE) 59.00/ea.
PL330F is a less expensive alternative to PL330. Quality is excellent.

PL331 1971-72 Fuel Gauge Sending Unit, 3/8" Inlet
- All Exc. SW (RE) 60.00/ea.

PL331 has a 1/4" a vapor return. Includes the sock filter and seal.

PL334C 1973-76 Fuel Gauge Sending Unit, 3/8" Inlet
- All Exc. SW (RE) 60.00/ea.

PL334CF does have a vapor return. Includes the sock filter and seal

PL334CF 1973-76 Fuel Gauge Sending Unit, 3/8" Inlet
- All Exc. SW (RE) 60.00/ea.

PL334CF does not have a vapor return. Includes the sock filter and seal.

PL334F 1977 Fuel Gauge Sending Unit, 3 Outlet
w/24 Gal Tank- All Exc. SW (RP) 140.00/ea.

PL334H 1977 Fuel Gauge Sending Unit, 2 Outlet
-All Exc. SW (RP)..... 155.00/ea.

PL334K 1977 Fuel Gauge Sending Unit, 2 Outlet
w/24 Gal Tank - All Exc. SW (RP) 92.00/ea.

PL334N 1977 Fuel Gauge Sending Unit,
SW 2 Outlet (RP)..... 62.00/ea.

PL334R 1977 Fuel Gauge Sending Unit,
SW 3 Outlet (RP)..... 90.00/ea.



PL338

PL338 1961-72 Fuel Gauge Sending Unit Retainer, 2 5/8" (GM)..... \$3.00/ea.

This retainer fits '61-'64 SW, '65-'66 FS, '69-'70 FS, and '69-'72 GP or any fuel gauge sending unit with a 2 5/8" lock ring.

PL338B 1967-77 Fuel Gauge Sending Unit Retainer, 3 7/8" (GM)..... 6.50/ea.

This retainer fits '67-'68 FS, '71-'76 FS, and '73-'77 GP or any fuel gauge sending unit with a 3 7/8" locking ring.



PL338D

PL338D 1955-64 Fuel Gauge Sending Unit Gasket (GM). 7.00/ea.

This is the flat gasket with five mounting holes.

PL338F 1961-72 Fuel Gauge Sending Unit Gasket -2 3/8" (GM) 3.00/ea.

PL338H 1967-77 Fuel Gauge Sending Unit Gasket -3 1/2" (GM) 10.00/ea.



PL338F



PL338J

PL338J 1961-77 Fuel Gauge Sending Unit Filter, 3/8" Line (GM)..... 14.00/ea.

PL338K 1961-77 Fuel Gauge Sending Unit Filter, 5/16" Line (GM)..... 16.00/ea.

This "sock" style filter goes on the sending unit inside the fuel tank.

PL338M 1957-64 Fuel Filler Tube O-Ring (RP)..... 4.00/ea.

GAS TANK STRAPS & HARDWARE



PL339 1957 Gas Tank Strap (RE) Disc.

PL339A 1958 Gas Tank Strap (RE) Disc.

PL339AJ 1961-64 Gas Tank Strap (RE) 37.00/pr.

PL340A 1969-70 Gas Tank Support Strap - GP (RE) 18.00/pr.

PL340B 1969-70 Gas Tank Straps w/Hardware Stainless Steel, Pair - GP (RP)..... 59.00/pr.

PL340F 1973-77 Gas Tank Straps, Pair - GP (RE) 35.00/pr.

PL340J 1973-76 Gas Tank Straps, Pair - FS Exc. SW (RE). 49.00/pr.

PL325C 1966-67 Fuel Tank Strap Hardware Kit, Exc. Wagon (AP)..... 4.00/kit

PL342JJ 1969-70 Gas Tank Strap Hardware Kit - GP (RE). 5.00/ea.



PL343J POR 15 Fuel Tank Sealer, Quart (AP)..... 35.00/qt.

Impervious to all fuels including alcohol, this sealer stops rust and corrosion, seals pinholes on seams, and remains flexible. Designed to be used in conjunction with other POR 15 components, Marine Clean and Metal Ready found in the Miscellaneous Section. A one quart container will seal up to a 25 gallon tank.

GAS CAPS



PL345

PL343T 1955-60 Gas Cap (RE)..... \$17.50/ea.

PL344 1962-64 Vented Gas Tank Cap - All Exc. SW (RE) Disc.

PL345 1965-70 Gas Tank Cap - Exc. SW (AP) 10.00/ea.

PL345C 1971-74 Gas Tank Cap- All, Vented(AP)..... 7.00/ea.

PL345C is a functional aftermarket replacement which differs in appearance from originals.

PL346 1970 Gas Tank Cap - SW Exc. Evaporative Emission System (GM) 18.00/ea.

PL346H 1975-77 Gas Tank Cap (GM)..... 11.50/ea.

GAS DOORS, BUMPERS & PLATE MOUNTING

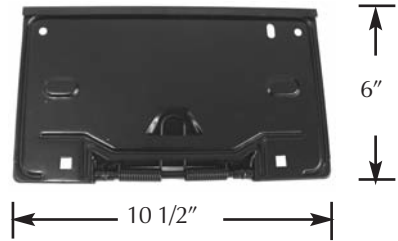

PL350AF

PL350AF 1965-68 Gas Door - All Exc. SW (APE)..... 32.00/ea.

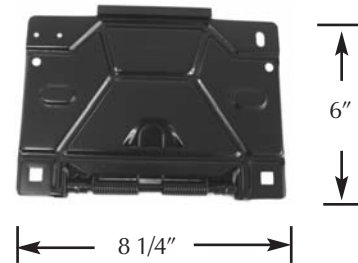

PL350AK

PL350AK 1969-77 Gas Door - All Exc. SW (APE)..... 32.00/ea.

For years the only gas door available was an incorrect GM part of poor quality (weak spring tension). Because of this, the industry lost sight of what was original factory equipment. In an ongoing effort to refine our product line, we have reproduced the exact doors with the correct spring design.



PL356

PL368

PL352 1955-56 Gas Door Bumper (RE) 4.00/pr.

PL353 1957 Gas Door Bumper Set - Exc. SW (RE).... 6.50/kit

PL354 1957 Gas Door Bumpers - SW (RE)..... 3.50/pr.

PL355 1958 Gas Door Bumpers - Exc. SW (RE)..... 2.00/pr.

PL356 1958 Gas Door Bumpers (RE)..... 3.50/pr.

PL357 1959 Gas Door Bumpers - Exc. SW (RE)..... 3.50/pr.

PL359 1960 Gas Door Bumpers - Exc. SW (RE)..... 2.00/pr.

PL365 1963-64 Gas Door Bumpers - Exc. SW (RE)..... 3.50/pr.

We have found these fit '61-'62 applications as well.

PL368 1965-77 Gas Door Bumpers - Exc. SW (GM) 6.00/pr.

PL369 1965-77 Gas Door Bumpers - SW (GM)..... 3.50/pr.

PL380 1963-72 Rear License Plate Mounting Package (RE) 5.50/ea.

LICENSE PLATE COMPONENTS



PL350BG

PL350BG 1955-56 License Plate Lamp Assemblies
- Safari & SW (RE)..... \$37.00/pr.

This set comes complete with a pair of lenses, gaskets, housings, bulbs, and wiring.

PL350BH 1955-56 License Plate Lamp Lens - Safari &
SW (RE) 8.00/pr.

PL350BJ 1955-56 License Plate Lamp Lens Gaskets (RE)... 4.50/pr.



PL350BN

PL350BN 1957 License Plate Lamp Lens
- All Exc. SW (RE) 12.00/pr.



PL350DA

PL350DA License Plate Lamp Assembly
- All exc. SW (RP)..... 21.00/ea.

This assembly is very similar to many we've seen on early Pontiacs, however, there are some minor differences; The lens is completely clear (no gray shielding) and the wire exits the right side instead of the left side.



PL350DB

PL350DB 1964-72 License Plate Lamp Lens (RE) 8.00/ea.

GM offered several different style lenses through the years. This lens may differ slightly in appearance but it makes a good replacement.

PL350DD 1964-72 License Plate Lamp Lens Gasket (GM).. 3.50/ea.

LICENSE PLATE POCKETS



PL350H 1969-70 Rear Bumper License Plate Pocket
- GP (RE) 225.00/ea.

PL350H is an excellent injection - molded reproduction. Correct in all aspects. Quality: Excellent.

PL350J 1971-72 Rear Bumper License Plate Pocket
- GP (RE) Inquire

Comments: We do not have an ETA at this time for PL350J.

BUMPER BOLTS & WASHERS



PL371

PL370 1955-63 Stainless Capped Round Head
Bumper Bolt w/Nut (RE) \$1.50/ea.



PL372

PL371 1964-72 Stainless Capped Pan Head Bumper
Bolt w/Nut 1.50/ea.

PL372 Bumper Serrated Round Washer (RE) ... 2.00/ea.

PL372A Bumper Bracket To Frame
Octagon Washer (RE) 2.00/ea.



PL372A

REAR BODY PANEL TO BUMPER SEAL



PL390 1955-56 Rear Body Panel to Bumper Seal (RE) ... 11.00/pr.

PL391 1957 Rear Body Panel to Bumper Seal (RE) ... 11.00/pr.

PL395 1960 Rear Body Panel to Bumper Seal (RE) ... Disc.

Note: PL390 through PL395 are the rubber seals between the body and the rear bumper.

REAR WINDOW PANELS



PL415

PL415 1965-66 Rear Window to Trunk Panel
-2 Door HT Exc. GP (RE)..... 128.00/ea.

PL420 1969-70 Rear Window to Trunk Panel
GP (RE) 65.00/ea.

These panels are reproductions of the often rusted panels between the rear window and the deck lid.

Add \$20.00 oversize fee to standard shipping for rear window panels.



**SAVE TIME
ORDER ONLINE**

**24
Hours
A
Day**

www.amesperf.com

REAR END TRIM

ELECTRICAL RELATED

ANTENNA COMPONENTS

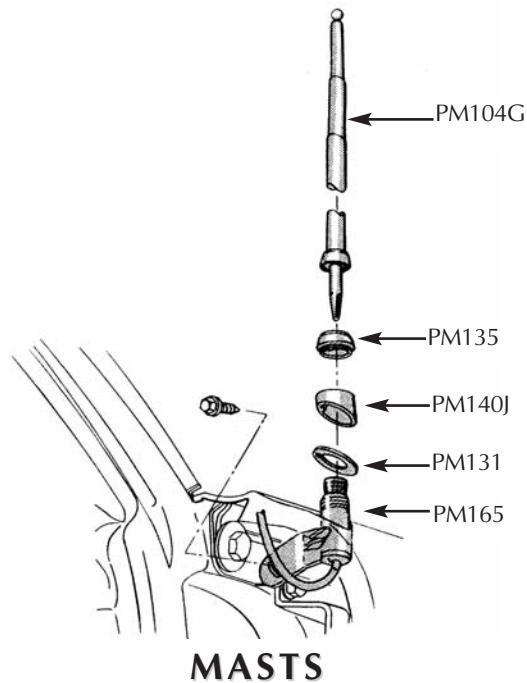

MASTS

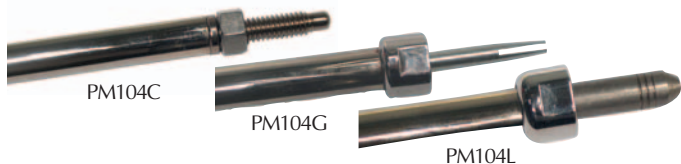

- PM104C** 1955-64 Antenna Mast (Oval Manual Mast w/Screw in Stud and Correct Oval Grooved Tip (RE)) \$99.00/ea.
- PM104G** Late 1964-66 Antenna Mast (Oval Manual Mast w/Forked End) (RE) 99.00/ea.
- PM104L** 1967-69 Antenna Mast (Oval Manual Mast w/Plug End and Correct Oval Grooved Tip (RE)) 99.00/ea.
- PM105** 1955-64 Antenna Mast (Round Manual Mast w/Male Nut and Spherical Tip) (RP) 25.00/ea.

PM105 is a round replacement mast that is similar to originals; however, there are a few differences. It has four sections instead of three, a bigger overall diameter, a check nut instead of the correct stationary nut, and it doesn't have the ring around the finial tip.

- PM110** 1967-69 Manual Antenna Mast Replacement (GM) 20.00/ea.

GM discontinued the telescoping three-section mast in favor of this replacement one-piece whip style.



PM104H



PM104M

- PM104H** 1964-66 Antenna Mast Nut (RE) 5.00/ea.
- PM104M** 1967-69 Antenna Mast Nut (RE) 5.00/ea.

These nuts are included on the above masts. PM104H is a captive nut that will require disassembly on the antenna for installation whereas PM104M simply slips over the top of the mast.

MOUNTING PADS



PM120



PM120A

- PM120** 1955-56 Manual Antenna Mast Pad (RE) \$3.00/ea.
- PM120A** 1957-58 Manual Antenna Mast Pad (RE) 7.50/ea.



PM120BA



PM120BB

- PM120BA** 1957 Mounting Pad - Power Antenna, Upper (RE) 16.00/ea.
- PM120BB** 1957 Mounting Pad - Power Antenna, Lower (RE) 10.00/ea.
- PM127** 1962-68 Manual Antenna Mast Pad (RE) 6.00/ea.
- PM131** 1969 Mounting Pad - Manual Antenna (RE) .. 6.00/ea.
- PM132** 1969 Mounting Pad - Power Antenna, Upper & Lower (RE) 6.50/pr.

Please inquire concerning antenna mast pads if your year is not listed. New reproductions are constantly becoming available.

NUTS, ADAPTERS & LEAD WIRES



PM135



PM140B

- PM135** 1960-69 Manual Antenna Base Nut (RE) 13.00/ea.
- PM140** 1961 Manual Antenna Adapter (RE) 19.00/ea.
- PM140B** 1962 Manual Antenna Adapter (RE) 30.00/ea.
- PM140D** 1963-64 Manual Antenna Adapter (RE) 19.00/ea.
- PM140F** 1965-66 Manual Antenna Adapter (RE) 27.00/ea.
- PM140J** 1967-68 Manual Antenna Adapter (RE) 19.00/ea.
- PM140L** 1969 Manual Antenna Adapter (RE) 14.00/ea.



PM145



PM150

- PM145** 1957 Power Antenna Adapter (RE) 19.00/ea.
- PM150** 1961-66 Power Antenna Base Nut (RE) 18.00/ea.

It has always been hard to re-chrome those slotted antenna base nuts. This part is ready to screw on for less than most re-chroming jobs and without the hassle.

ELECTRICAL RELATED

MANUAL ANTENNA BODIES



PM155

PM153J 1964 Power Antenna Adapter (RE)..... Disc.
PM155 Antenna Lead Firewall Grommet (RE) .. \$3.50/ea.

Note: This grommet fits cars with a 9/16" firewall hole and lead diameter of 7/32".

PM155H 1962-64 Antenna Lead Wire w/Grommet (RE) ... 19.00/ea.
PM155J 1965-69 Antenna Lead Wire w/Grommet (RE) ... 19.00/ea.

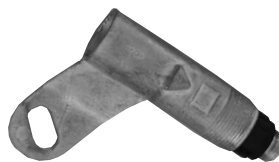

PM164

PM162 1963-64 Antenna Body w/o Lead (w/Screw-in Style Mast) (RE)..... Disc.

PM163 1964 Antenna Body w/o Lead (w/Fork Style Mast) (RE) \$38.00/ea.

PM164 1965-66 Antenna Body w/o Lead (RE) Disc.

PM165 1967-68 Antenna Body w/o Lead (RE) 38.00/ea.

PM166 1969 Antenna Body w/o Lead - FS (RE) Disc.

Note: These are the bodies mounted under the fender that the antenna screws into. Most originals are broken or missing.

PM170 1970-72 Antenna Lead W/Windshield Antenna (RE) 19.00/ea.

PM170D 1969-72 Cowl Panel to Hood Antenna Ground Clip - GP (GM) 5.00/ea.

Note: This also fits 1970 FS.



PM170D

AFTERMARKET RADIO COMPONENTS

SECRET AUDIO © & CD CHANGER



SS Secret Audio© Radio PM180R

With this Secret Audio© system the original radio stays in place retaining a totally stock appearance. This system uses a Radio Frequency (RF) remote that allows for a concealed unit.

PM180R 1955-77 SS Secret Audio© Radio (AP) \$279.00/ea.

PM180R features: AM/FM Stereo, 35X4 watts, CD changer controls, Separate bass & treble, 4-way fader, Electronic tuning w/clock, RCA pre-outs, 30 presets, wireless radio frequency remote, With the RF remote, the tuner/amp can be hidden.

PM180T 1955-77 SS Secret Audio© Radio w/10 Disc CD Changer (AP)..... 549.00/ea.

PM180V CD Changer, 10 Disc (AP) 289.00/ea.

Use PM180V only with the Secret Audio© Systems.

AFTERMARKET ANTENNAS

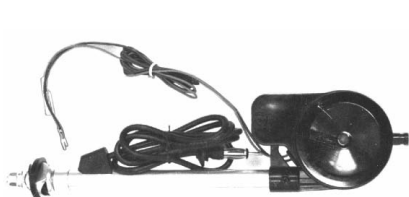

Power Antenna PM185A



Hideaway Antenna PM185D

PM185A Universal Power Antenna Kit (AP)..... 79.00/kit

PM185D Universal Hide-away Antenna Asm. (AP) 30.00/ea.

SPEAKERS



6X9 Rear Dual Voice Coil Speaker PM182L



Under Cover Speakers

Dual voice coil speakers offer stereo sound from a single front speaker. PM182B through PM182S must be used with our afterproduct radios.

PM182B 1955-56 Front Dual Voice Coil Dash Speaker (AP) \$49.00/ea.

PM182D 1957-58 Front Dual Voice Coil Dash Speaker (AP) 49.00/ea.

PM182F 1959-64 Front Dual Voice Coil Dash Speaker (AP) 55.00/ea.

PM182H 1965-68 Front Dual Voice Coil Dash Speaker (AP) Inquire

PM182L 1955-67 6X9 Rear Dual Voice Coil Speaker (AP) 49.00/ea.

PM182L is ideal for '55-'67 single rear speaker applications.

PM182P 1955-72 6X9 Rear Speakers, 80 Watt, Pair (AP) .. 79.00/pr.

PM182S 1955-72 6X9 Rear Speakers, 200 watt, Pair (AP). 79.00/pr.

Note 1: Some modifications may need to be made to the steel rear package shelf for dual rear speaker applications.

PM182V Under Cover Speakers, 120 Watt, Pair (AP)..... 120.00/pr.

Notes: M188V is low-profile under-seat speaker package. It features a 5 1/2" woofer and Piezo tweeter in each enclosure. Enclosure measures 3" tall X 8 1/2" wide X 11 1/4" long.

PM182X Under Cover Speakers, 200 Watt, Pair (AP)..... 140.00/pr.

Notes: PM182X is like PM182V with an 8" woofer and Piezo tweeter in each enclosure. Enclosure measures 3" tall X 11" wide X 12 1/2" long.

These speakers must be used with our afterproduct radios. Use of these speakers with original radios will damage the radio.

ELECTRICAL RELATED

DIRECTIONAL SIGNAL SWITCHES



PM200

Note: For years, the identification process for telling the difference between Boyne and Delco switches for 1967 -68 has been very challenging. Boyne switches are usually blue while Delco are white; however, this is not always the case. Other ways to tell them apart are by the cancelling mechanism where Boyne switches have plastic arms that contact the cancel cam and Delco uses steel cancelling springs. Another way is by identifying the hole on the collar that the hazard knob goes through. On Boyne systems, the hole is round while Delco has a 'doghouse' shaped hole. You must know your application and type before ordering since Delco and Boyne switches are not interchangeable. It is also advised that you count wires and note the colors of the wires in the connector for proper application.

PM195	1965-66 Directional Signal Switch w/Tilt Wheel (RE)	\$49.00/ea.
PM200	1967-68 Directional Signal Switch (Exc. Cornering Lamps) (Boyne) (RE).....	75.00/ea.
PM201	1967-68 Directional Signal Switch (Exc. Cornering Lamps) (Delco) (GM).....	65.00/ea.
PM202	1967-68 Directional Signal Switch (w/Cornering Lamps) (Boyne) (RE).....	Inquire
PM203	1969-77 Directional Signal Switch (w/Cornering Lamps) - All (GM)	39.00/ea.
PM204	1969-77 Directional Signal Switch (Exc. Cornering Lamps) - All (GM).....	39.00/ea.
PM204R	1969-77 Directional Signal Switch w/Correct Connector (RE).....	29.00/ea.

This is a reproduction alternative to the newer GM style (PM204). Using PM204R eliminates the need of an adaptor to connect to your dash harness 1969-'74 cars.

PM210	1965-66 Directional Signal Switch Repair Kit (Boyne Switches) (AP).....	Inquire
PM211	1967-77 Directional Signal Switch Repair Kit (Delco Switches) (AP).....	Inquire

Note: PM210 and PM211 are kits to repair Boyne and Delco directional signal switches. Boyne switches are usually blue plastic and Delco switches are white plastic.

HAZARD LIGHT KNOBS & FLASHER



PM214H PM214J PM214L

PM214H	1967-68 Hazard Light Knob, Chrome (RE)	8.00/ea.
PM214J	1967-77 Hazard Light Knob (GM)	7.00/ea.
PM214L	1964-77 Hazard & Turn Signal Flasher (AP).....	5.00/ea.

COLUMN CANCEL CAMS



PM216

PM216	1965-66 Tilt Column Cancel Cam (RE).....	29.00/ea.
--------------	--	-----------

This cam operates the turn signal switch and activates the horn relay. The shape of the reproduction is not like original but operation is the same.

PM216D	1967-68 Tilt Column Cancel Cam (GM)	\$12.00/ea.
PM216G	1969-75 Non-Tilt Column Cancel Cam (GM)	17.00/ea.
PM216H	1969-75 Tilt Column Cancel Cam (GM)	27.00/ea.
PM216K	1976-77 Non-Tilt Column Cancel Cam (GM)	27.00/ea.
PM216L	1976-77 Tilt Column Cancel Cam (GM)	Disc.



PM220

PM220	1967-77 Turn Signal Cancel Springs, Pair (GM) ..	3.50/pr.
--------------	--	----------

In some cases, a "broken" turn signal switch may be fixed inexpensively with these springs.

HEADLIGHT SWITCHES



PM229T

PM231D

PM229	1960-62 Headlight Switch (RP)	Disc.
PM229E	1963-67 Headlight Switch w/o Hideaway Headlights (GM/RE)	Disc.
PM229T	1967-68 Headlight Switch w/Hideaway Headlights - GP & Bonneville (GM-RE)	83.00/ea.

Although not an exact replacement, this combination GM-reproduction includes vacuum fittings for hideaway headlight control.

PM230	1968-74 Headlight Switch - FS w/o Hideaways (GM)	23.00/ea.
PM231	1969-72 Headlight Switch - GP (GM)	23.00/ea.
PM230	1973-74 Headlight Switch - GP (GM)	23.00/ea.
PM231	1975-77 Headlight Switch - All (GM).....	23.00/ea.
PM231D	1963-77 Headlight Switch Pigtail Connector (AP)	5.50/ea.



PM235

PM238M

PM235	1955-57 Headlight Dimmer Switch (RP)	30.00/ea.
PM238	1961-77 Headlight Dimmer Switch - All w/Floor Mounted (GM)	10.00/ea.
PM238K	1973-77 Headlight Dimmer Switch Column Mounted w/Tilt (GM)	Disc.
PM238M	1961-77 Headlight Dimmer Switch Pigtail Connector (AP)	4.50/ea.

NEUTRAL SAFETY SWITCHES



PM239B

PM238W	1965-66 Neutral Safety Switch All AT w/Column Shift (RE).....	34.00/ea.
PM238X	1965-68 Neutral Safety Switch All AT w/Console Shift (RE)	49.00/ea.
PM239B	1969-73 Neutral Safety Switch - All AT (AP)	19.00/ea.
PM239D	1974-77 Neutral Safety Switch - All AT (AP)	20.00/ea.

STOP LIGHT SWITCHES



PM239L



PM239PJ

- | | | |
|----------------|---|-------------|
| PM239L | 1965-75 Stop Light Switch, Exc. Cruise (GM-RP) | \$10.00/ea. |
| PM239N | 1967-77 Stop Light Switch w/Cruise (GM-RP) | 14.00/ea. |
| PM239P | 1976-77 Stop Light Switch, w/PB and
Exc. Cruise (GM-RP)..... | 13.00/ea. |
| PM239PJ | 1965-77 Stop Light Switch Retainer Clip (RE) | 2.50/ea. |



PM240B

- | | | |
|---------------|----------------------------------|------------|
| PM240B | 40 Amp Circuit Breaker (RP)..... | \$5.00/ea. |
|---------------|----------------------------------|------------|
- PM240B is used with various options such as power windows, power seat and for convertible tops.

TRANSMISSION KICKDOWN SWITCH



PM239R

- | | | |
|---------------|---|-----------|
| PM239R | 1967-77 Transmission Kickdown Switch,
AT(GM-RP)..... | 24.00/ea. |
| PM239Q | 1965-66 Kickdown Switch Rubber Boot, M40 At (RE) | 23.00/ea. |

RELAYS



PM239TA

- | | | |
|----------------|------------------------------------|---------|
| PM239TA | 1961-75 Power Seat Relay (RE)..... | Inquire |
|----------------|------------------------------------|---------|



PM239TC

- | | | |
|----------------|---|---------|
| PM239TC | 1970 FS & 1970-72 GP
Power Accessory Relay (GM)..... | Inquire |
|----------------|---|---------|
- Different years used this relay for various accessories including power tops, power windows, power seats, power locks, etc. (Refer to the PM239TC photo for identification.)
- | | | |
|----------------|--|---------|
| PM239TF | 1971-75 Power Accessory Relay - FS (RE) | Inquire |
| PM239TF | 1976-77 Power Window and Power Sunroof
Relay (RE) | Inquire |

FUSES & BREAKERS



- | | | |
|----------------|--|----------|
| PM240AA | 4 Amp (Long) Glass Tube Fuse (RP)..... | 1.00/ea. |
| PM240AB | 4 Amp (Short) Glass Tube Fuse (RP)..... | 1.00/ea. |
| PM240AC | 10 Amp (Long) Glass Tube Fuse (RP)..... | 1.00/ea. |
| PM240AD | 15 Amp Glass Tube Fuse (RP) | 1.00/ea. |
| PM240AE | 20 Amp (Long) Glass Tube Fuse (RP)..... | 1.00/ea. |
| PM240AF | 20 Amp (Short) Glass Tube Fuse (RP)..... | 1.00/ea. |
| PM240AG | 25 Amp Glass Tube Fuse (RP) | 1.00/ea. |
| PM240AH | 30 Amp Glass Tube Fuse (RP) | 1.00/ea. |

Applications and quantities vary. Please check originals before ordering.

LIGHT BULBS

- | | | |
|---------------|--|-------|
| PM240F | 1969-72 "NOS" Directional Signal Bulb
Painted Bulb (NOS)..... | Disc. |
|---------------|--|-------|

Correctly painted orange, #1157 bulb. Afterproduct bulbs have amber glass.



LB1156



LB1157A



LB1445



LB0067



LB0089



LB0090



LB0093



LB0211



LB1155

- | | | |
|----------------|-------------------------------|----------|
| LB0067 | #67 Light Bulb | 1.50/ea. |
| LB0089 | #89 Light Bulb | 1.50/ea. |
| LB0090 | #90 Light Bulb | 1.50/ea. |
| LB0093 | #93 Light Bulb | 1.50/ea. |
| LB0194 | #194 Light Bulb | 1.50/ea. |
| LB0194A | #194A Amber Light Bulb | 1.50/ea. |
| LB0211 | #211 Light Bulb..... | 1.50/ea. |
| LB1003 | #1003 Light Bulb | 1.50/ea. |
| LB1155 | #1155 Light Bulb..... | 1.50/ea. |
| LB1156 | #1156 Light Bulb..... | 1.50/ea. |
| LB1157 | #1157 Light Bulb..... | 1.50/ea. |
| LB1157A | #1157A Amber Light Bulb | 1.50/ea. |
| LB1445 | #1445 Light Bulb | 1.50/ea. |
| LB1893 | #1893 Light Bulb | 1.50/ea. |
| LB1895 | #1895 Light Bulb | 1.50/ea. |

Note: When ordering light bulbs, please look at originals and take the part number from it. The bulbs above use the standardized numbering system. Bulb replacement numbers can be found in most owners manuals.

IGNITION SWITCHES



PM244

- | | | |
|--------------|--|-----------|
| PM241 | 1955-56 Ignition Switch (NOS)..... | Inquire |
| PM242 | 1957-58 Ignition Switch (NOS)..... | Inquire |
| PM243 | 1959-61 Ignition Switch (NOS)..... | Inquire |
| PM244 | 1962 Ignition Switch (RE) | 79.00/ea. |
| PM245 | 1963-64 Ignition Switch w/AC (NOS) | Disc. |
| PM246 | 1963-64 Ignition Switch w/o AC (NOS) | Disc. |
| PM247 | 1965 Ignition Switch (NOS)..... | Inquire |
| PM248 | 1966 Ignition Switch (NOS)..... | Disc. |

ELECTRICAL RELATED

PM249	1967	Ignition Switch (NOS).....	\$69.00/ea.
PM250	1968	Ignition Switch (NOS).....	Inquire
PM251	1969-70	Ignition Switch (Exc. Tilt Wheel) - All (NOS).....	24.00/ea.
PM251B	1969-70	Ignition Switch (w/Tilt Wheel) - All (NOS).....	49.00/ea.
PM252	1971-77	Ignition Switch (Exc. Tilt Wheel) - All (GM)	19.00/ea.
PM253	1971-77	Ignition Switch (w/Tilt Wheel) - All (GM)	17.00/ea.
PM254	1963-64	Ignition Bezel Tool (RE)	13.00/ea.

IGNITION LOCK CYLINDERS



PM260	1955-64	Ignition Lock Cylinder w/Original-Style Key (NOS).....	13.00/ea.
PM260A	1955-64	Ignition Lock Cylinder w/Late-Style Key (NOS)	13.00/ea.
PM262	1961-64	Ignition Lock Cylinder w/Original-Style Key (NOS).....	13.00/ea.
PM262A	1961-64	Ignition Lock Cylinder w/Late-Style Key (NOS)	13.00/ea.
PM265	1965	Ignition Lock Cylinder w/Original-Style Key (NOS).....	26.00/ea.
PM265A	1965	Ignition Lock Cylinder w/Late-Style Key (NOS)	Disc.
PM266	1966	Ignition Lock Cylinder w/Original-Style Key (NOS).....	Disc.
PM266A	1966	Ignition Lock Cylinder w/Late-Style Key (NOS)	Disc.
PM267	1967	Ignition Lock Cylinder w/Original-Style Key (NOS).....	Disc.
PM268	1968	Ignition Lock Cylinder w/Original-Style Key (NOS).....	17.00/ea.
PM268A	1968	Ignition Lock Cylinder w/Late-Style Key (NOS)	15.00/ea.
PM269	1969-77	Ignition Lock Cylinder w/Key - All (NOS).....	15.00/ea.

Note: See Section Seventeen for matched sets of locks.

IGNITION KEYS



PM365



PM366

PM360	1955-66	Ignition Key	2.00/ea.
<i>Note: PM360 is original-style with the knockout removed. These no longer have Briggs & Stratton logo.</i>			
PM362	1967	Ignition Key - A	2.00/ea.
<i>Note: PM362 uses late key design similar to PM366.</i>			
PM363	1967	Ignition Key - A (NOS)	3.50/ea.
<i>Note: PM363 is original-style with knockout. These no longer have Briggs & Stratton logo.</i>			
PM364	1968	Ignition Key - C (GM)	2.00/ea.
<i>Note: PM364 uses the late key design similar to PM366.</i>			
PM365	1968	Ignition Key Blank - C (NOS)	3.50/ea.
<i>Note: PM365 is original-style with knockout. These no longer have Briggs & Stratton logo.</i>			
PM366	1969	Ignition Key - E (GM)	2.00/ea.
PM367	1970	Ignition Key - J (GM).....	2.00/ea.
PM368	1971	Ignition Key - A (GM).....	2.00/ea.
PM369	1972	Ignition Key - C (GM)	2.00/ea.
PM370	1973	Ignition Key - E (GM)	2.00/ea.
PM371	1974	Ignition Key - J (GM)	2.00/ea.
PM372	1975	Ignition Key - A (GM).....	2.00/ea.
PM373	1976	Ignition Key - C (GM)	2.00/ea.
PM374	1977	Ignition Key - E (GM)	2.00/ea.

RADIO SPEAKERS & COMPONENTS



PM305	1965-68	Radio Speaker, Front (RE).....	\$42.00/ea.
PM306	1969-70	Radio Speaker, Front - FS (GM)	Disc.
PM309	1971-72	Radio Speaker w/Tape Player or Stereo - FS (GM)	19.00/ea.
PM309B	1964-77	Original Style 6X9 Rear Radio Speaker (RP)	35.00/ea.
PM310	1971-72	Radio Speaker, Rear - FS SW (GM)	48.50/ea.

Most original cars equipped with rear speakers have long since lost their speaker enclosures. These reproductions are exact down to the special spring clip used for attachment. 1964-67 cars need one per car while the '68-'77 models used two.



PM330

PM330	1964-65	Rear Speaker Enclosure - Exc. CVT (RE)	23.00/ea.
PM331	1966-70	Rear Speaker Enclosure - All Exc. CVT (RE)	23.00/ea.



PM331D

PM331D	1968-72	Rear Speaker Housing Bolt - CVT (RE) ..	5.50/ea.
PM332	1971-72	Rear Speaker Enclosure - GP (RE)	23.00/ea.
PM333	1971-77	Rear Speaker Enclosure -FS Exc. CVT (GM)	13.00/ea.
PM333A	1971-77	Rear Speaker Enclosure Bracket - FS Exc. CVT (GM)	Disc.
PM333B	1971-77	Rear Speaker Enclosure Retainer - FS Exc. CVT (GM)	5.00/ea.

ENGINE SENDING UNITS



PM353



PM356P

PM350	1959-65	Oil Pressure Sending Unit w/o Rally Gauges (GM)	5.00/ea.
PM351	1966-77	Oil Pressure Sending Unit w/o Rally Gauges - All (GM)	5.00/ea.
PM352	1965-66	Oil Pressure Sending Unit w/Rally Gauges 0-60 PSI - All (RP).....	32.00/ea.
PM353	1967-77	Oil Pressure Sending Unit w/Rally Gauges 0-80 PSI - All (GM)	89.00/ea.
PM354	1967-77	Oil Pressure Sending Unit w/Rally Gauges (AP).....	22.00/ea.
PM354K	1959-72	Temperature Sending Unit w/o Rally Gauges (Correct Single Terminal)(NOS)	Disc.
PM355	1959-69	Temperature Sending Unit w/o Rally Gauges (Incorrect Double Terminal)(AP)	16.00/ea.
PM356	1963-77	Temperature Sending Unit w/Rally Gauges - All (GM)	17.00/ea.
PM356P	1965-77	Brass Elbow, 45°, for Oil Pressure Sending Unit - All w/ Rally Gauges (GM).....	4.50/ea.

This elbow screws into the oil filter adapter and houses the oil pressure sending unit for rally gauge applications only. Addition of this commonly missing fitting will enhance the quality of your restoration.

HORNS & RELAYS



PM379

PM380

PM379 1955-77 Original-Style Horn Set (RE)..... \$99.00/set

PM379 resembles originals, except for the universal mounting brackets that are assembled with screws rather than original style rivets. Exhibit original "Delco-Remy" and "Made in USA" markings.

PM380 1955-77 LH Horn (High Note) (GM-RP) 39.00/ea.

PM383 1955-77 RH Horn (Low Note) (GM-RP) 39.00/ea.

PM383B 1955-77 LH Horn (High Note) (AP) 20.00/ea.

PM383C 1955-77 RH Horn (Low Note) (AP) 20.00/ea.

PM380-PM383C no longer resemble OEM and require electrical connection modifications. Use only when originality is not a concern.



PM402

PM400 1955-56 Horn Relay (AP) 27.00/ea.

PM401 1957-58 Horn Relay (AP) 22.50/ea.

PM402 1959-62 Horn Relay (AP) 22.50/ea.

Note: This relay does not have the battery cable junction connection. For that style relay see PM403.

PM403 1961-64 Horn Relay (NOS)..... Inquire

PM401 1966-67 Horn Relay (AP) 22.50/ea.

PM406 1968 Horn Relay (AP) Disc.

PM407 1969-71 Horn Relay (RE) 49.00/ea.

PM408 1972-76 Horn Relay (AP) Disc.

PM409 1977 Horn Relay (AP) 17.00/ea.

GENERATOR & ALTERNATOR COMPONENTS



PN269

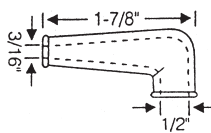

PN267J



PN268K

PN269J Starter, Generator, and Distributor Tag Fasteners (RE) 2.00/ea.

These are the little round-headed, fluted shank rivets that attach various tags to starters, generators, and early distributors. A must-have detail item for the purist.

PN267J 1961-62 Generator and Ignition Coil Electrical Connection Boot (RE) 14.00/ea.

PN268K 1962-74 Alternator Plastic End Cap - Red (RE) 9.00/ea.

PN268L 1962-74 Alternator Plastic End Cap - Black (RE) 9.00/ea.

PN268M 1975-77 Alternator Plastic End Cap - Black (GM) 3.50/ea

PN268K and PN268L are exact reproductions of the plastic caps used on all alternators. Cap covers positive lead and is a necessity for detailed restorations.

REMANUFACTURED ALTERNATORS



PM415 1961-70 Alternator, Remanufactured - All V8 Exc. AC - 55 AMP (AP) \$55.00/ea.

PM416 1961-70 Alternator, Remanufactured - All V8 w/ AC - 55 AMP (AP) 55.00/ea.

PM417 1971-77 Alternator, Remanufactured - All V8 78 AMP (GM) 109.00/ea.

PM417A 1971-77 Alternator, Remanufactured - All V8 80 AMP (AP) 105.00/ea.

Note 1: PM415-PM417 requires a \$12.00 refundable core charge. PM417A requires a \$25.00 refundable core charge. Cores must be returned in the box that the new alternator arrived in.

Note 2: PM415 & PM416 are afterproduct remanufactured units which carry a 90 day warranty.

Note 3: PM417 is a remanufactured AC/Delco unit which carries a one-year warranty.

PM418B 1961-70 Chrome Alternator - All V8, 65 AMP W/Ext Reg. (AP)..... 189.00/ea.

PM418C 1971-77 Chrome Alternator - All V8, 63 AMP W/Int Reg.(AP) 189.00/ea.

PB418B and PM418C are after-market "Powermaster" units with a chrome fan and 2 1/4" pulley.

PM419KR 1962-74 Alternator Positive Wire Cap Retainer, Red (RE)..... 4.50/ea

PM419LB 1962-74 Alternator Positive Wire Cap Retainer, Black (RE) 4.50/ea.

PM419P 1962-70 Alternator 2 Wire Replacement "Pig tail" 4.00/ea.

PM419T 1971-77 Alternator 3 Wire Replacement "Pig tail" 4.00/ea.

VOLTAGE REGULATORS & JUNCTION BLOCKS



PM422N



PM420AB



PM423D

PM420 1955-62 Voltage Regulator (NOS) 35.00/ea.

This NOS piece with correct inside adjustments does not have Delco Script on the cover. Shelf wear will be present and require repainting in most cases.

PM421 1963-66 Voltage Regulator - All Exc. 62amp or T.I. (AP)..... 69.00/ea.

PM422 1967-68 Voltage Regulator - All Exc.62amp or T.I. (AP) 69.00/ea.

PM422NC 1963-68 Voltage Regulator - All Exc. 62amp or T.I. (NOS)..... 20.00/ea.

We have acquired a very limited supply of this 100% original NOS regulators with the correct staggered "Delco Remy" on the cover.

PM423A 1969-70 "Delco Remy" Voltage Regulator - All Exc. Internal Regulated Alternator (CSI option) (GM) 65.00/ea.

DELCO REMY is stamped straight across cover unlike the original which was staggered.

PM420AB 1967 Convertible Battery Cable Lead Junction Block (RE)..... 5.50/ea.

PM423D 1968-70 Voltage Regulator Radio Capacitor W/Brkt 31.00/ea.

ELECTRICAL RELATED

BATTERIES



PM450 1955-60 Model 2SMR53 Tar Top Battery ,
700 CCA (RE)..... \$275.00/ea.

Note: PM450 does not have the exact original case configuration for 1955.

PM450M 1961-63 Model DC12 Battery WO Flange..... 240.00/ea,

PM450S 1961-63 Model DC12 Battery W/O Flange
Maintenance Free..... 325.00/ea.

PM451 1963-65 Model DC12 (w/o Flange) Tar Top
Battery, 500 CCA (RE)..... 240.00/ea.

PM451F 1963-65 Maintenance-Free Model DC12 (w/o
Flange) Tar Top Battery, 700 CCA (RE) .. 325.00/ea.

PM452 1966 Model DC12 (w/Flange) Tar Top
Battery, 500 CCA (RE)..... 240.00/ea.

PM452F 1966 Maintenance-Free Model DC12 (w/
Flange) Tar Top Battery, 700 CCA (RE). 325.00/ea.

Note: 1966 is a transition year between PM452-PM452F and
PM453B-PM453C. PM451-PM452F have black caps w/ yellow
letters.

PM453B 1966-71 Model R59HC Energizer, 700 CCA (RE) 309.00/ea.

PM453C 1966-71 Maintenance-Free Model R59HC
Energizer, 700 CCA (RE)..... 325.00/ea.

Very few 1971 applications used PM453B / PM453C (most cars
were equipped with PM453D side terminal battery).

PM453D 1971-75 Model R89HC Side Terminal Battery
700 CCA (RE)..... 330.00/ea.

PM453F 1971-75 Maintenance-Free Model R89HC
Side Terminal Battery 700 CCA (RE)..... 325.00/ea.

PM453F case is textured with Delco circles.

PM453H 1971-75 Maintenance-Free Model R89W
Side Terminal Battery 700 CCA (RE)..... 325.00/ea.

PM453H case is textured with vertical lines.

Note 1: These batteries all have group 24 dimensions (L = 10 1/2", W
= 6 7/8" and H = 8 3/4").

Note 2: Batteries must be prepaid and will be drop-shipped "dry-
charged" from our distributor.

Note 3: Discounts do not apply to batteries.

Add \$40.00 oversize fee to standard shipping for batteries.



PM453L

PM453L Battery Quick Disconnect (AP)..... 8.00/ea.

BATTERY FLOAT CHARGER



PM454 Automatic Float Charger (AP)..... 17.00/ea.

Skip the aggravation of a jump-start by keeping your vehicle's battery
fully charged. Used on 12V batteries while in storage or during cold
weather, the floating circuit maintains a full charge without overcharg-
ing. Includes an automatic safety shut off.

BATTERY TOPPER



PM453CA

PM453CA 1966-71 R59 Battery Topper w/ Caps (AP)..... \$49.00/ea.

PM453HT 1971-75 R89W Battery Topper w/ Caps (AP)..... 49.00/ea.

This topper gives any maintenance free flat-top battery the correct look
of the 1966-71 R59 battery.

TOP POST BATTERY CABLES



PM499J 1955 Top Post Battery Cables (RE)..... 78.00/pr.

PM499L 1956-57 Top Post Battery Cables (RE)..... 75.00/pr.

PM499N 1958 Top Post Battery Cables (RE)..... 75.00/pr.

PM500 1959-60 Battery Cables (RE)..... 75.00/pr.

PM503 1961-62 Battery Cables w/AC (RE)..... 78.00/pr.

PM505 1961-62 Battery Cables w/o AC (RE)..... 78.00/pr.

PM507 1963 Battery Cables - All Exc. GP (RE)..... 78.00/pr.

PM507A 1963 Battery Cables - GP (RE)..... 78.00/pr.

PM509 1964 Battery Cables w/Black Positive
Lead (RE)..... 78.00/pr.

PM509A 1964 Battery Cables w/Red Positive
Lead (RE)..... 78.00/pr.

It seems '64 could have either black or red positive lead wires. Please
check your originals before ordering.

PM511 1965-66 Negative Battery Cable Only (RE)..... 39.00/ea.

PM513 1967 Battery Cables (RE)..... Inquire

PM511 and PM513 are available with only one accessory lead. It
appears a few '65-'67 cars had two accessory leads. Because of lim-
ited production, these cables are not available.

PM515 1968 Battery Cables (RE)..... Inquire

PM517 1969 Battery Cables - All Exc. GP (RE)..... 78.00/pr.

Comments: These cables have been researched using GM blueprints
and scarce originals. The spring-ring casting has been used on con-
course Corvettes for years.

Very good—Outside head diameter somewhat larger than original.

SIDE TERMINAL BATTERY CABLES



PM530H

PM530 1970 Negative Battery Cable - 455 HD
(25" long) - FS (RE)..... 42.00/ea.

PM530C 1971 Negative Battery Cable - All 455
or HD (30" long) - FS (GM)..... Disc.

PM530F 1971 Negative Battery Cable (35" long)
- GP (GM)..... Disc.

PM530H 1972-77 Negative Battery Cable - All (GM)..... Disc.

PM531B 1970 Positive Battery Cable - All 455 HD
(55" long) (GM)..... 46.50/ea.

PM531D 1970 Positive Battery Cable - 350/400 Std.
(63" long) - FS (GM)..... Disc.

PM531E 1970 Positive Battery Cable - 350/400 HD
(53" long) - FS (GM)..... Disc.

PM531G 1971 Positive Battery Cable (45" long)
- FS (RE)..... 42.00/ea.

Battery cables continue on next page.

Battery cables continued.

PM531B	1971	Positive Battery Cable (55" long) - GP (RE).....	\$46.50/ea.
PM531B	1972	Positive Battery Cable - 400 HD & 455 (55" long) - GP (RE).....	46.50/ea.
PM531J	1972	Positive Battery Cable - 400 Std. (55" long) - GP (GM).....	28.00/ea.
PM531K	1972-74	Positive Battery Cable - 350/400 Std. (50" & 24" Wire) - All (RE).....	42.00/ea.
PM531M	1973-74	Positive Battery Cable - 350/400 HD/ 455 (50" & 10" Wire) - All (RE).....	42.00/ea.
PM531J	1975-76	Positive Battery Cable (55" long) - All exc. HD Battery (GM).....	28.00/ea.
PM531B	1975-76	Positive Battery Cable (55" long) - All w/HD Battery (RE).....	46.50/ea.
PM531P	1977	Positive Battery Cable (65" long) - GP (GM).....	Disc.



PM535	PM535	Negative Cable Mounting Star Washer & Fine Thread Nut (AP).....	4.00/ea.
PM535A	PM535D	Negative Cable Mounting Star Washer & Coarse Thread Nut (AP).....	4.00/ea.

PM535 and PM535A are the special star washer and nut for mounting the negative battery cable to head bolt.

PM535D	1971-77	Battery Side Terminal Bolt Kit (AP).....	3.00/kit
---------------	---------	--	----------

JUNCTION BLOCK STARTER CABLES



PM550

PM550	1959-60	Junction Block Starter Cable (32 inches long) (RE).....	39.00/ea.
PM550	1961-62	Junction Block Starter Cable, Super Duty Only (32 inches long) (RE).....	39.00/ea.
PM551	1961-62	Junction Block Starter Cable, Exc. SD (20 inches long) (RE).....	39.00/ea.
PM552	1963-64	Junction Block Starter Cable, Exc. SD (24 inches long) (RE).....	39.00/ea.
PM553	1963	Junction Block Starter Cable 421SD only (RE).....	39.00/ea.

PM550 through PM552 is the black 4-gauge positive cable that connects the junction block to the starter. It comes complete with the correct fabric shielding.

WIRE LOOM & WRAP



PM580

PM580		1/4" ID Split Ribbed Flexible Plastic Wire Loom (RE).....	1.50/ft.
PM581		3/8" ID Split Ribbed Flexible Plastic Wire Loom (RE).....	1.50/ft.
PM582		1/2" ID Split Ribbed Flexible Plastic Wire Loom (RE).....	1.50/ft.
PM583		3/4" ID Split Ribbed Flexible Plastic Wire Loom (RE).....	1.50/ft.



PM589

PM587	1/4" ID Tar Wire Loom (RE).....	\$1.50/ft.
PM588	3/8" ID Tar Wire Loom (RE).....	1.50/ft.
PM589	1/2" ID Tar Wire Loom (RE).....	1.50/ft.



PM630

PM630	3/4" Wiring Harness Vinyl Wrap (RE) ...	13.00/100 ft. roll
PM632	1 1/4" Wiring Harness Vinyl Wrap (RE).	13.00/100 ft. roll

This non-adhesive vinyl wrap was originally used by GM for many years.

PRINTED DASH CIRCUITS



PM620

PM620	1969-72	Printed Dash Circuit w/Rally Gauges - GP (6295410) (RE).....	82.00/ea.
PM621	1969-72	Printed Dash Circuit w/o Rally Gauges (6295409) - GP (RE).....	82.00/ea.
PM622	1972	Printed Dash Circuit w/o Rally Gauges w/o Aux, w/Seat Belt Warning (8910337) -GP.....	82.00/ea.

REPLACEMENT LIGHT SOCKETS



PM645

PM645	1969-77	Instrument Panel Light Socket, All w/ 5/8" hole (RP).....	2.00/ea.
--------------	---------	--	----------

These are the twist-in sockets that make contact with dash circuit and light-up instruments. These require #194 Light bulb which is not included. Before ordering please verify hole diameter in dash.



PM649



PM651

PM649	Replacement Brake/Taillight Socket, 2 Wire (RP) .	6.00/ea.
PM650	Replacement Brake/Taillight Socket, 3 Wire (RP) .	6.00/ea.

Before ordering please check application. PM644 grounds through taillight housing while PM650 has extra ground lead. These require 1157 bulb which is not included.

PM651	Replacement Side Marker Light Socket, 2 Wire (RP)	3.00/ea.
--------------	---	----------

PM649-PM651 are replacement sockets and will need to be spliced into existing harness. #194 light bulb and wire connectors not included.

ELECTRICAL RELATED

WIRING HARNESSSES

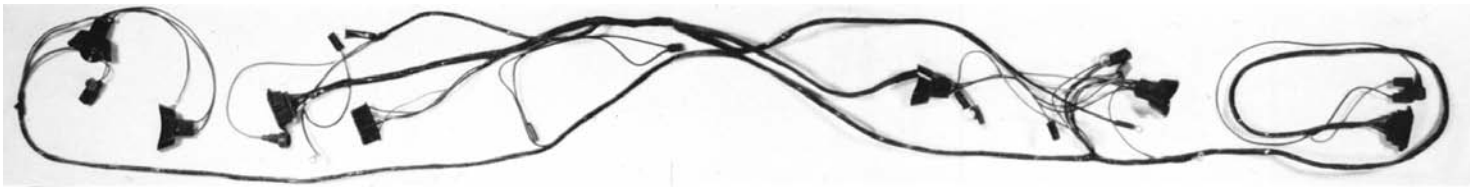

We carry an extensive line of wiring harnesses to solve your electrical problems. These harnesses are made to exact original specifications making installation a simple plug-in operation.

Please refer to the following abbreviations when ordering wiring harnesses.

UNIT. DIST. = UNITIZED DISTRIBUTOR
 TI = TRANSISTORIZED IGNITION
 RA = RAM AIR
 AC = AIR CONDITIONING
 AT = AUTOMATIC TRANSMISSION
 MT = MANUAL TRANSMISSION
 DEF = DEFROSTER

EXT. REG. = EXTERNAL REGULATOR (VOLTAGE REGULATOR MOUNTED ON CORE SUPPORT)
 INT. REG. = INTERNAL REGULATOR (VOLTAGE REGULATOR IN ALTERNATOR)
 HD = HEAVY DUTY
 PW = POWER WINDOWS
 ATC = AUTOMATIC TEMPERATURE CONTROL

We carry an extensive line of wiring harnesses for 1964-74 full size and 1969-74 Grand Prix models. We can provide engine, forward light, dash and air conditioning harnesses for most 1955-63 models. Please inquire with specific needs and for prices.

Harnesses will be shipped directly to you from our west coast manufacturer. Allow 4-6 weeks for delivery.

ENGINE HARNESSSES

For 1955-63 Engine Harnesses look in Dash Harness section.

Note: Many new engine harnesses can now be ordered converted from points distributor to HEI for an additional cost. (Does not apply to 1969-70 cars) Please inquire when ordering.

When placing an order for wiring harnesses, please include the following information: Year, engine size, transmission, with or without factory gauges, tachometer (in dash or hood mounted), console or column shift, coupe or convertible, non-factory components, power options, internal regulator with alternator, unitized distributor.

Due to limited availability of certain connectors many harnesses require customer supplying original prior to ordering.

PM04555 1964	Engine Harness, V8	\$102.00/ea.		
PM05190 1964	Engine Harness, V8 w/AC.....	109.00/ea.		
PM05925 1965	Engine Harness, V8	102.00/ea.	PM13480 1969	Engine Harness, V8 with Gauges, w/HD Alt. (62 amp) - FS.....
PM05930 1965	Engine Harness, V8 w/Std. AC	109.00/ea.		\$145.00/ea.
PM06050 1965	Engine Harness, V8 w/ATC-AC	109.00/ea.	PM13290 1969	Engine Harness, V8 w/Ext. Reg - GP
PM09345 1966	Engine Harness, V8	102.00/ea.	PM12870 1969	Engine Harness, V8 w/Int. Reg - GP.....
PM09545 1966	Engine Harness, V8 w/Std. AC	109.00/ea.	PM13650 1970	Engine Harness, V8, w/o Gauges, MT-FS
PM09550 1966	Engine Harness, V8 w/ATC-AC	109.00/ea.	PM13690 1970	Engine Harness, V8, MT, w/Gauges-FS,
PM10230 1967	Engine Harness, V8	105.00/ea.	PM13710 1970	Engine Harness, V8, MT w/o Gauges, w/HD Alt. (62 amp)-FS
PM10235 1967	Engine Harness, V8 w/Std. AC	109.00/ea.		155.00/ea.
PM10240 1967	Engine Harness, V8 w/ATC-AC	109.00/ea.	PM13705 1970	Engine Harness, V8, AT w/o Gauges -FS
PM10290 1967	Engine Harness, V8 w/TI	119.00/ea.	PM13700 1970	Engine Harness, V8, AT w/Gauges-FS...
PM10295 1967	Engine Harness, V8 w/TI & Std. AC	119.00/ea.	PM15580 1970	Engine Harness, V8, AT w/HD Alt. (62 amp)FS
PM10300 1967	Engine Harness, V8 w/TI & ATC-AC	119.00/ea.		155.00/ea.
PM11355 1968	Engine Harness, V8	145.00/ea.	PM15560 1970	Engine Harness, V8, MT-GP
PM11350 1968	Engine Harness, V8 w/AC.....	145.00/ea.	PM15565 1970	Engine Harness, V8, AT-GP.....
PM12175 1968	Engine Harness, V8 w/Int. Reg.	145.00/ea.	PM16070 1971	Engine Harness, V8, 350 CI, AT-FS
PM12180 1968	Engine Harness, V8 w/Int. Reg. & AC ...	145.00/ea.	PM15915 1971	Engine Harness, V8, 350 CI , MT-FS
			PM16705 1971	Engine Harness, V8, ALL w/Unit. Dist.-FS
			PM16060 1971	Engine Harness, V8, MT-GP
			PM16065 1971	Engine Harness, V8, AT, w/o AC-GP.....
			PM37984 1971	Engine Harness, V8, AT,w/AC- GP
			PM16075 1971	Engine Harness, V8, ALL w/Unit. Dist.-GP
			PM16955 1972	Engine Harness, V8-FS
			PM16970 1972	Engine Harness, V8 w/Unit. Dist.-FS
			PM16945 1972	Engine Harness, V8-GP
			PM16950 1972	Engine Harness, V8 w/Unit. Dist.-GP ...
			PM17030 1973	Engine Harness, V8
			PM17085 1973	Engine Harness, V8 w/Unit. Dist.
			PM17060 1974	Engine Harness, V8
			PM17110 1974	Engine Harness, V8 w/Unit. Dist.
				175.00/ea.
				175.00/ea.

Note 1: Please specify when ordering '64-'68 engine harnesses if you have a 2-wire or 4-wire voltage regulator.

Note 2: Please send original firewall bulkhead connector when ordering '64-'68 engine harnesses.

PM12840 1969	Engine Harness, V8, w/o Gauges, w/o Ext. Reg., Exc. GP	147.00/ea.
PM12845 1969	Engine Harness, V8 w/Gauges, w/ext Reg -FS	145.00/ea.
PM12850 1969	Engine Harness, V8 w/o Gauges, w/Int. Reg.-FS.....	145.00/ea.
PM12855 1969	Engine Harness, V8 w/Int. Reg. & Gauges- FS	145.00/ea.
PM12860 1969	Engine Harness, V8 w/o Gauges w/HD Alt. (62 amp) - FS.....	145.00/ea.

AIR CONDITIONING HARNESSSES

PM02270	1956	Air Conditioning Harness	\$119.00/ea.
PM02595	1957	Air Conditioning Harness	119.00/ea.
PM02780	1958	Air Conditioning Harness	119.00/ea.
PM06260	1958	Air Conditioning Extension Harness, Clutch Wire w/Cool Pack	20.00/ea.
PM02870	1959	Air Conditioning Harness w/Circulaire .	119.00/ea.
PM02915	1959	Air Conditioning Harness w/Cool Pack	54.00/ea.
PM06260	1959	Air Conditioning Extension Harness, Clutch Wire w/Cool Pack	20.00/ea.
PM03220	1960	Air Conditioning Harness w/Circulaire .	119.00/ea.
PM03170	1960	Air Conditioning Harness w/Cool Pack .	54.00/ea.
PM03605	1961	Air Conditioning Harness w/Circulaire .	119.00/ea.
PM03585	1961	Air Conditioning Harness w/Cool Pack	54.00/ea.
PM03835	1962	Air Conditioning Harness w/Cool Pack (Universal)	54.00/ea.
PM04425	1963	Air Conditioning Harness, Field Installed	119.00/ea.
PM04585	1964	Air Conditioning Harness, Field Installed	119.00/ea.
PM05180	1964	Air Conditioning Harness, Factory Installed.....	119.00/ea.
PM05820	1965	Air Conditioning Harness, Field Installed	119.00/ea.
PM05725	1965	Air Conditioning Harness, Std.....	119.00/ea.
PM05880	1965	Air Conditioning Harness w/ATC	119.00/ea.
PM38177	1970	Air Conditioning Harness w/ Heated Defrost, Engine Side- GP	89.00/ea.
PM38178	1970	Air Conditioning Harness w/ Heated Defrost, Dash Side- GP.....	67.00/ea.

DASH HARNESSSES

Note 1: Please send us original fuse blocks when ordering '58-'65 dash harnesses. New blocks are not available.

Note 2: Additional discounts do not apply to dash harnesses.

PM02210	1955	Dash & Engine Compt. Harness w/Directional Signals	506.00/ea.
PM02265	1956	Dash & Engine Compt. Harness w/Directional Signals	506.00/ea.
PM02420	1957	Dash & Engine Compt. Harness.....	506.00/ea.
PM02675	1958	Dash & Engine Compt. Harness.....	506.00/ea.
PM02795	1959	Dash & Engine Compt. Harness.....	536.00/ea.
PM00985	1959	Dash & Engine Compt. Harness w/AC..	536.00/ea.
PM03225	1960	Dash & Engine Compt. Harness w/Manual Control Heater.....	536.00/ea.
PM03055	1960	Dash & Engine Compt. Harness w/Push Button Control Heater	536.00/ea.
PM03060	1960	Dash & Engine Compt. Harness w/AC..	536.00/ea.
PM03440	1961	Dash Instrument Cluster Extension Harness	76.00/ea.
PM03445	1961	Dash & Engine Compt. Harness w/Manual Control Heater.....	536.00/ea.
PM03450	1961	Dash & Engine Compt. Harness w/Push Button Control Heater	536.00/ea.
PM03455	1961	Dash & Engine Compt. Harness w/AC..	536.00/ea.
PM03440	1962	Dash Instrument Cluster Extension Harness	76.00/ea.
PM03775	1962	Dash & Engine Compt. Harness w/Push Button Control Heater	536.00/ea.
PM04040	1962	Dash & Engine Compt. Harness w/AC and Alt.....	536.00/ea.
PM03780	1962	Dash & Engine Compt. Harness w/AC and Gen.	536.00/ea.
PM04065	1963	Dash & Engine Harness.....	506.00/ea.
PM04310	1963	Dash & Engine Harness w/AC.....	506.00/ea.
PM04545	1964	Dash Harness, Col. Shift, AT or All MT .	506.00/ea.
PM04550	1964	Dash Harness, Col.Shift, AT or All MT w/AC.....	506.00/ea.
PM05120	1964	Dash Harness, Console Shift, AT	506.00/ea.
PM05125	1964	Dash Harness, Console Shift, AT w/AC.	506.00/ea.

PM00975	1965	Dash Harness, Col.Shift, AT or All MT ..	\$506.00/ea.
PM05980	1965	Dash Harness, Col. Shift, AT or All MT w/Std. AC	506.00/ea.
PM09265	1965	Dash Harness, Col.Shift, AT or All MT w/ATC-AC	506.00/ea.
PM05990	1965	Dash Harness, Console Shift, AT	506.00/ea.
PM05985	1965	Dash Harness, Console Shift, AT w/Std. AC	506.00/ea.
PM00980	1965	Dash Harness, Console Shift, AT w/ATC-AC	506.00/ea.
PM09335	1966	Dash Harness, Col. Shift, AT or All MT .	506.00/ea.
PM09350	1966	Dash Harness, Col.Shift, AT or All MT w/Gauges	506.00/ea.
PM09340	1966	Dash Harness, Console Shift, AT	506.00/ea.
PM09355	1966	Dash Harness, Console Shift, AT w/Gauges	506.00/ea.
PM10360	1967	Dash Harness, Col. Shift, AT or All MT .	519.00/ea.
PM10515	1967	Dash Harness, Col. Shift, AT or All MT w/Gauges	519.00/ea.
PM10365	1967	Dash Harness, Console Shift, AT	519.00/ea.
PM10520	1967	Dash Harness, Console Shift, AT w/Gauges	519.00/ea.
PM11330	1968	Dash Harness, Col. Shift, AT or All MT .	519.00/ea.
PM11340	1968	Dash Harness, Col. Shift, AT or All MT w/Gauges	519.00/ea.
PM11335	1968	Dash Harness, Console Shift, AT	519.00/ea.
PM11345	1968	Dash Harness, Console Shift, AT w/Gauges.....	519.00/ea.
PM12810	1969	Dash Harness-FS.....	519.00/ea.
PM12815	1969	Dash Harness-FS w/Gauges.....	519.00/ea.
PM13530	1969	Dash Harness-GP	519.00/ea.
PM13535	1969	Dash Harness-GP w/Gauges	519.00/ea.
PM15835	1970	Dash Harness-FS.....	519.00/ea.
PM15840	1970	Dash Harness-FS w/Gauges.....	519.00/ea.
PM15845	1970	Dash Harness-GP	519.00/ea.
PM15850	1970	Dash Harness-GP w/Gauges	519.00/ea.
PM16215	1971	Dash Harness-FS, All.....	519.00/ea.
PM16225	1971	Dash Harness-GP	519.00/ea.
PM16670	1971	Dash Harness-GP w/Gauges	519.00/ea.
PM17295	1973	Dash Harness-GP w/Gauges	519.00/ea.
PM17305	1974	Dash Harness-GP w/Gauges	519.00/ea.

FORWARD LAMP HARNESSSES

PM04060	1963	Forward Lamp Harness	145.00/ea.
PM04560	1964	Forward Lamp Harness	159.00/ea.
PM05615	1965	Forward Lamp Harness	159.00/ea.
PM09360	1966	Forward Lamp Harness	159.00/ea.
PM10305	1967	Forward Lamp Harness-FS.....	159.00/ea.
PM10310	1967	Forward Lamp Harness-GP	169.00/ea.
PM11360	1968	Forward Lamp Harness-FS.....	159.00/ea.
PM11365	1968	Forward Lamp Harness-GP	169.00/ea.

Note: Please send original firewall bulkhead connector when ordering '64-'68 forward lamp harnesses.

PM13400	1969	Forward Lamp Harness-FS.....	159.00/ea.
PM12905	1969	Forward Lamp Harness-GP	159.00/ea.
PM13695	1970	Forward Lamp Harness-FS.....	159.00/ea.
PM13620	1970	Forward Lamp Harness-GP	159.00/ea.
PM13625	1970	Forward Lamp Harness-GP w/Cornering Lamps.....	159.00/ea.
PM15895	1971	Forward Lamp Harness-FS.....	159.00/ea.
PM15900	1971	Forward Lamp Harness-GP	159.00/ea.

LAMP EXTENSION HARNESSSES

PM04270	1963	Lamp Extension Harness, Dash Harness to Ammeter, Clock & Gas Gauge Lamps	23.00/ea.
PM05765	1965	Lamp Extension Harness, Dash Harness to Clock.....	17.00/ea.
PM06185	1965	Lamp Extension Harness, Dash Harness to Vacuum Gauge.....	17.00/ea.
PM09595	1966	Lamp Extension Harness, Dash Harness to Heater or AC Control Panel Indicator	17.00/ea.

TACHOMETER HARNESSSES

PM04000	1962	Tachometer Harness	\$33.00/ea.
PM04250	1963	Tachometer Harness	33.00/ea.
PM04320	1963	Tachometer Harness w/TI	37.00/ea.
PM04605	1964	Tachometer Harness	33.00/ea.
PM04610	1964	Tachometer Harness w/TI	37.00/ea.
PM06245	1965	Tachometer Harness	33.00/ea.
PM06250	1965	Tachometer Harness w/TI	37.00/ea.
PM06245	1966	Tachometer Harness	33.00/ea.
PM10050	1966	Tachometer Harness w/TI	37.00/ea.
PM11040	1967	Tach. Harness, Hood Mounted	23.00/ea.
PM12380	1968	Tach. Harness, Dash Mounted	20.00/ea.
PM12375	1968	Tach. Harness, Dash Mounted	23.00/ea.
PM12380	1969	Tach. Harness, Dash Mounted-GP	20.00/ea.
PM17250	1969	Tach. Harness, Hood Mounted-GP	23.00/ea.
PM15645	1970	Tach. Harness, Dash Mounted-GP	20.00/ea.
PM17250	1970	Tach. Harness, Hood Mounted-GP	23.00/ea.
PM15645	1971	Tach. Harness, Dash Mounted w/o Unit. Dist.-GP	20.00/ea.
PM17360	1971	Tach. Harness, Dash Mounted w/Unit. Dist.-GP	20.00/ea.
PM17250	1971	Tach. Harness, Hood Mounted-GP	23.00/ea.
PM16885	1972	Tach. Harness, Dash Mounted w/o Unit. Dist.-GP	20.00/ea.
PM16890	1972	Tach. Harness, Dash Mounted w/Unit. Dist.-GP	20.00/ea.
PM17250	1972	Tach. Harness, Hood Mounted-GP	23.00/ea.
PM00515		Hei Tach Adaptor Harness	8.00/ea

These tach harnesses work only with original tachometers.

CONSOLE HARNESSSES

PM05595	1964	Console Harness, AT	68.00/ea.
PM00970	1964	Console Harness, MT	26.00/ea.
PM06190	1965	Console Harness, AT	68.00/ea.
PM00970	1965	Console Harness, MT	26.00/ea.
PM10045	1966	Console Harness, AT	48.00/ea.
PM09555	1966	Console Harness, MT	26.00/ea.
PM10045	1967	Console Harness, AT	48.00/ea.
PM11135	1967	Console Harness, MT	26.00/ea.
PM10045	1968	Console Harness, AT	48.00/ea.
PM11135	1968	Console Harness, MT	26.00/ea.

TAILLIGHT HARNESSSES

PM08980	1963	Rear Lamp Harness-GP	129.00/ea.
PM06500	1963	Rear Lamp Harness, Intermediate-GP ..	129.00/ea.
PM06840	1964	Rear Lamp Harness-GP	129.00/ea.
PM06500	1964	Rear Lamp Harness, Intermediate-GP ..	129.00/ea.

SPEED WARNING HARNESSSES

PM09560	1966	Speed Warning Harness	27.00/ea.
PM09560	1967	Speed Warning Harness	27.00/ea.
PM09560	1968	Speed Warning Harness	27.00/ea.
PM13500	1969	Speed Warning Harness	20.00/ea.
PM13645	1970	Speed Warning Harness	20.00/ea.

GAUGE HARNESSSES

PM07105	1964	Auxiliary Gauge Panel Harness w/Aux. Gauges	48.00/ea.
PM06240	1965	Auxiliary Gauge Panel Harness w/Aux. Gauges	48.00/ea.

MISCELLANEOUS HARNESSSES

PM08530	1959	Power Window Harness, Door & Quarter, RH- Bonneville & Catalina 2drHT	\$156.00/ea.
PM08765	1961-62	Power Window Harness, All 2 Door	190.00/ea.
PM06615	1963-64	Power Window Harness, Rear Quarter, RH- Cat. 2-door Sedan	67.00/ea.
PM06620	1963-64	Power Window Harness, Rear Quarter, LH- Cat. 2-door Sedan	67.00/ea.
PM06630	1963-64	Power Window Harness, Rear Quarter, LH, Cvt.	67.00/ea.
PM06635	1963	Power Window Harness, Rear Quarter, RH, All Hardtops	67.00/ea.
PM06640	1963-64	Power Window Harness, Rear Quarter, LH, 2drHT	67.00/ea.
PM08085	1965-66	Power Window Harness, Rear Quarter, LH or RH, Cat. 2-door Sedan	101.00/ea.
PM07370	1965-66	Power Window Harness, Cvt Rear Quarter Window, LH or RH,	94.00/ea.
PM08005	1965-67	Courtesy Lamp Harness, Center Roof Mounted Dome Lamp, All Exc. Cvt.	29.00/ea.
PM08030	1965-66	Courtesy Lamp Harness- Bonneville & Starchief 4drHT	29.00/ea.
PM32405	1959	Courtesy Lamp Harness, Side Roof Rail Lamp- Bonneville 2drHT	21.00/ea.
PM32410	1959	Courtesy Lamp Harness, Side Roof Rail Lamp- Bonneville 4drHT	15.00/ea.
PM39440	1970-72	Power Door Lock, Window Relay, and Adaptor Harness, All	29.00/ea.

WIRING DIAGRAMS

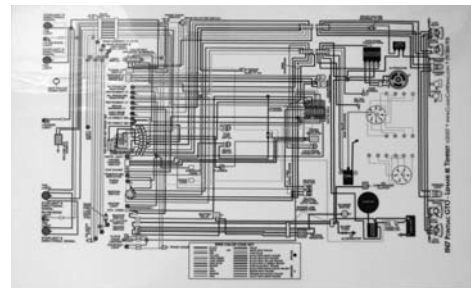

These new diagrams are laminated sheets with color coded wires that correspond with your cars original wire colors. Custom designed and easier to read than original black and white schematics from 40 year old shop manuals. These are a great time saver when replacing your harnesses. Single-page 11" x 17" includes engine, forward lamp, dash, and rear lamp wiring.

PM100AA	1955-56	Wiring Diagram	16.00/ea.
PM100AB	1957	Wiring Diagram	16.00/ea.
PM100AC	1958	Wiring Diagram	16.00/ea.
PM100AD	1959	Wiring Diagram	16.00/ea.
PM100AE	1960	Wiring Diagram	16.00/ea.
PM100AF	1961-62	Wiring Diagram	16.00/ea.
PM100AH	1963	Wiring Diagram	16.00/ea.
PM100AJ	1964	Wiring Diagram	16.00/ea.
PM100AK	1965	Wiring Diagram	16.00/ea.
PM100AL	1966	Wiring Diagram	16.00/ea.
PM100AM	1967	Wiring Diagram	16.00/ea.
PM100AN	1968	Wiring Diagram	16.00/ea.
PM100AP	1969	Wiring Diagram - FS	16.00/ea.
PM100AR	1969	Wiring Diagram - GP	16.00/ea.
PM100AS	1970	Wiring Diagram - GP	16.00/ea.
PM100AT	1971	Wiring Diagram - GP	16.00/ea.

ENGINE COMPONENTS

ENGINE DETAILING PAINTS



PN430



PN433



PP152



PP155AD



PP155AG



PP155AJ



PP352



PN407



PN407A



Aerosol paints cannot be shipped by air or outside the Continental United States.

- PN430** 1964-65 Pontiac Blue Engine Paint, 11 oz. Aerosol Can (AP) \$6.00/ea.
- PN431** 1966-70 Pontiac Blue Metallic Engine Paint, 11 oz. Aerosol Can (AP) 6.00/ea.
- PN431T** 1971-74 Pontiac Blue Non-Metallic Engine Paint, 11 oz. Aerosol Can (AP) 6.00/ea.

For those looking for an original color match we do not recommend using PN431T. This paint shade is lighter than the original blue.

Note:

- PN433** Diamond Clear Metal, 11 oz. Aerosol Can (AP) 13.00/ea.

Creates clear, tough, and flexible coatings every time! Ideal for brass, aluminum, steel, die-cast, and cast iron. Non-yellowing formula resists chips, cracks, and fading. Use in extremes up to 350°F. Satin Finish.

- PP152** "Aluma Blast" Aluminum Paint, 12 oz. Aerosol (AP) 12.00/ea. Use this spray on any parts that need that clean original aluminum finish. We found it was particularly great for castings like transmissions.



PW112



PW113

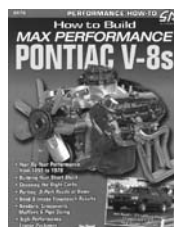

PW114C

- PW112** Pontiac High-Performance Engine Design & Blueprint Assembly by Craig Hendrickson & Kern Osterstock 20.00/ea.

This is another fine book written by drag racers Craig Hendrickson and Kern Osterstock, well-known for their original work at H-O Racing Specialties; it delves into various modifications to increase power from your Pontiac. They also outline the construction of a full-competition engine for street and strip. 96 pages with 31 illustrations.

- PW113** Pontiac Heavy-duty Parts and Specs by Craig Hendrickson and Kern Osterstock 10.00/ea.

Another H-O books, this softbound publication details parts and specifications for all high-performance Pontiacs of the 60's and 70's—31 pages.

- PW114C** How to Build Maximum Performance Pontiac V8's by Jim Hand 18.00/ea.

PW114C covers a range from mild performance upgrades to all-out high-performance build-ups for 1955-79 Pontiac V8's. Includes information on carburetors, intakes, heads, exhaust, etc.

- PP155AD** Charcoal Gray Zinc Phosphate, 11oz Aerosol (AP) \$12.00/ea.

Duplicates OEM charcoal gray zinc phosphate coating used on hood hinges & latches, shifter rods, and various suspension components.

- PP155AG** Silver Cad, 11oz Aerosol (AP) 12.00/ea.

P119AG duplicates the bluish silver tint of original cadmium plating used on carburetor linkages, alternator pulleys, transmission linkages, and other various applications.

- PP155AJ** Clear Zinc, 11oz Aerosol (AP)..... 12.00/ea.

P119AJ duplicates the blue/gray OEM plating used on disc brake dust shields, coil brackets, throttle cable brackets, vacuum advances, relays, etc.

- PP154** Black Semi-Gloss Engine Compartment Paint - Lacquer (AP) 12.00/ea.

This is a true semi-gloss paint available in a spray can. Usually a difficult paint to match, this Eastwood product is an excellent paint for engine compartment detailing.

- PN407** Exhaust Manifold Coating, Pint(AP)..... 25.00/pt.
- PN407A** Exhaust Manifold Coating, Aerosol (AP). 16.00/ea.

This high-quality Eastwood product is an excellent dressing for original manifolds as well as our reproductions. Fortified with 25% stainless steel, this high-temperature coating will give your manifolds new cast-iron appearance for thousands of miles.

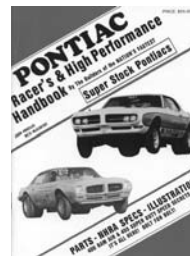

PW109



PW110

- PW109** Pontiac Racer's High-Performance Handbook by Pete McCarthy 20.00/ea.

Written from hands-on experience by three California drag racers. It completely explores all facets of high-performance Pontiac engines. The book covers part numbers, casting numbers, and the author's view of best blocks, heads, cams, etc. 100 pages with 82 illustrations. This book deals almost exclusively with performance Pontiac engines.

- PW110** Pontiac Muscle Car Performance 1955-79 by Pete McCarthy 32.00/ea.

This publication is the most definitive work on Pontiac engines and drive trains ever attempted. It contains the information of PW109 plus numbers for all engine components from 1955 to 1979. Pete spent years on this project which also includes histories and documentation of the factory racecars. (224 pages).

Comments: The best.

VALVE COVERS & COMPONENTS

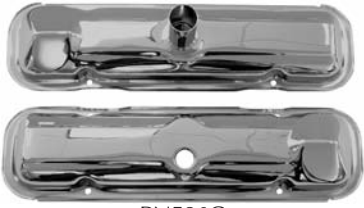

PN526C

PN526C 1959-64 Chrome Valve Covers w/Push On Style Cap (Covers only) (APE)..... \$119.00/pr.

These are offered because many customers have asked for this style chrome cover as an excellent dress up item.

Note: This set includes one cover with a stack and one with a plug hole. Requires 1 PN534R cap.

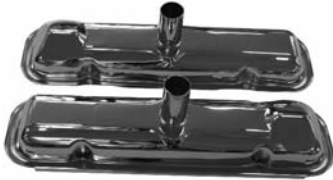

PN526CA 1959-64 Chrome Valve Covers w/Push-On Style Caps (Covers only) (APE) 139.00/pr.

Note: Thi set uncludes 2 covers with push-on style cap stacks. Requires 2 PN534R caps.



PN526CH

PN526CH 1962-63 Super-Duty 421 Valve Covers (Paint to Match) (RE)..... 299.00/pr.

Extremely rare and difficult to find originals. These new reproductions will facilitate Super Duty restorations.



PN526E

PN526D 1964 Chrome Valve Covers w/Twist In Style Cap (Covers only) (APE)..... 129.00/set

PN526E 1965 Chrome Valve Covers (APE)..... 129.00/set



PN526G

PN526F 1966 Chrome Valve Covers (APE)..... 119.00/set

PN526G 1967-77 Chrome Valve Covers (APE)..... 99.00/set

Quality: Excellent

Comments: Both stamping and chrome quality are good to excellent.

Note: Valve covers do not come with gaskets or bolts.

PN526GA 1967-77 Cast Aluminum Valve Covers - All Pontiac V8 (GM-RP)..... Disc.

AS GM's retail has soared past \$420.00/Pair, we have decided to discontinue carrying these covers.



PN526GBA

PN526GBA 1967-77Edelbrock Cast Aluminum Valve Covers - All Pontiac V8 (AP) \$155.00/pr.

PN526GBA is a very nice aluminum ribbed valve cover set with the "Edelbrock" raised script. Includes push-in chrome cap. Breather, bolts, and gaskets are not included. Use PN527FA bolts with these covers.

PN526GBC 1967-77Edelbrock Chrome Valve Covers - All Pontiac V8 (AP)..... 65.00/pr.

Chrome plating and overall quality of PN526GBC are considered good.

PN526GBC does not include bolts, gaskets, or breathers.

STANDARD VALVE COVER KITS



PN527N

PN527N 1967-77 Valve Covers, Standard Gaskets & Bolts 139.00/kit

Note: Contains 1 pr. of PN526G valve covers, 1 pr. of PN527G gaskets and 1 set of PN527F bolts.

PN527P 1967-77 Valve Covers, Hi-Performance Gaskets & Bolts..... 139.00/kit

Note: Contains 1 pr. of PN526G valve covers, 1 pr. PN527H gaskets and 1 set of PN527FA bolts.

DELUXE VALVE COVER KITS



PN528A 1959- early 64 Deluxe Chrome Valve Cover Kit 195.00/kit

PN528C 1965 Deluxe Chrome Valve Cover Kit 189.00/kit

PN528D 1966 Deluxe Chrome Valve Cover Kit 189.00/kit

PN528E 1967 Deluxe Chrome Valve Cover Kit 169.00/kit

PN528F 1968-77 Deluxe Chrome Valve Cover Kit 150.00/kit

Valve Cover components continue on next page

VALVE COVER BOLTS & GASKETS

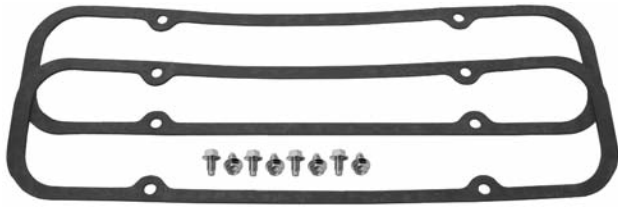

PN527K

PN527K 1955-77 Standard Valve Cover Gaskets & Bolts (GM)..... \$40.00/kit

Note: Contains 1 pr. of PN527G gaskets and 1 set of PN527F bolts.

PN527M 1955-77 Hi-Performance Valve Cover Gaskets & Bolts (AP)..... 42.00/kit

Note: Contains 1 pr. of PN527H gaskets and 1 set of PN527FA bolts.



PN527F

PN527F 1955-77 Zinc-Plated Valve Cover Bolts exc. RA IV or 455 HO (8 pcs.) (APE)..... 16.50/set

These are identical to original GM valve cover bolts (5/16" thread x 9/16" long with a 7/16" hex head).

PN527FA 1969-72 Zinc Plated Valve Cover Bolts, set All RA IV or 455HO (8 pieces) (APE)..... 16.50/set

These are identical to original GM RA IV and 455HO valve cover bolts (5/16" thread X 21/32" long with a 7/16" hex head). PN527H gaskets must be used in conjunction with these bolts.

PN527G 1955-77 Standard Valve Cover Gaskets (AP)..... 23.00/pr.

These gaskets are original GM neoprene approximately .140" thick. Use for all applications except modified valve trains. Use PN527F with these gaskets.

PN527CE 1964-77 Standard Cork Valve Cover Gaskets (AP) 21.00/pr.

We have seen cork gaskets used originally on 1964-69 applications; however, for longevity, we recommend PN527G.

PN527H 1955-77 Hi-Performance Valve Cover Gaskets (AP) 28.00/pr.

These Hi-Performance cork gaskets are 1/4" thick for use with those engines modified with extreme valve trains or extensive baffle assemblies. Use PN527FA with these gaskets.

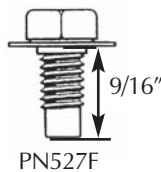

PN527F

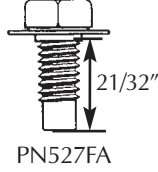

PN527FA

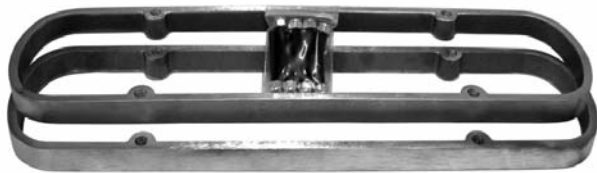

PN526L

PN526GB 1955-77 3/8" Valve Cover Spacers (AP)..... 109.00/pr.

PN526L 1955-77 3/4" Valve Cover Spacers (AP)..... 129.00/pr.

PN526GB & PN526L are used in roller-rocker applications or when early style OEM-style valve covers are used on later-style heads.

PN526M Valve Cover Bolts For Use w/PN526GB 5.50/kit



PN495

PN495 1958-66 Valve Cover Wire and/or Vacuum Hose Retainer (RE) \$15.00/ea.

These retainers were used in 1958-60 cars w/AC, 1961 All, 1962 cars w/AT and All 1963-66 cars.



PN495B

PN495B 1968-69 Switch Harness Support (RE)..... 23.00/ea.

This support mounts to the two center intake manifold bolts on the passenger side.

Note: Applications for this part are 1968 All, and 1969 All AT.



PN495J

PN495J 1968-77 Valve Cover Wire Clips (RE)..... 11.00/pr.

These are the cad-plated clips that are held in place by the valve cover bolts. PP101 plastic straps snap into these clips and retain the engine wire harness.



PN500A

PN500 1963-65 & '67 Valve Cover Plug (RE) 4.00/ea.

PN500A 1963-65 & '67 "Correct" Valve Cover Plug (RE) .. 8.00/ea.

For the purest, PN500A exhibits original shape with the correct "Bulls-eye" ring on the top and GM part number with 'FK66' on the underside.



PN500



PN501

PN501 1968-77 Valve Cover Vent Pipe Grommet (GM). 3.00/ea.

OIL BREATHER CAPS



PN530

PN530 1955-57 Valve Cover Oil Breather Cap, Twist-On (Exc. '57 F1 and 3x2 BBL) (Painted) (RP) 16.00/ea.

PN531 1957 Valve Cover Oil Breather Cap, Push-On w/F1 or 3x2 BBL (Painted) (RP) 12.00/ea.

PN531 1958 Valve Cover Oil Breather Cap, Push-On (Painted) (RP) 12.00/ea.

PN530 1959-64 Valve Cover Oil Breather Cap, Twist-On (Exc. '63-'64 3x2 BBL, 421 HO, and SD) (Painted) (RP) 16.00/ea.

PN531 1963-64 Valve Cover Oil Breather Cap, Push-On w/3x2 BBL, 421 HO, and SD (Painted) (RP) 12.00/ea.

PN530 1965-67 Valve Cover Oil Breather Cap, Twist-On (Painted) (RP) 16.00/ea.

Note: PN530 and PN531 are replacement parts from GM that do not match the original equipment. They are painted gray with smooth tops. They fit and function fine.

PN534R 1959-64 Valve Cover Oil Breather Cap, Push-On (Type FB-39 Chrome, All exc. Calif.) (RP-RE) 39.00/ea.

PN534R will work with PN526C or PN526CA valve covers.

PN534T 1964 Valve Cover Oil Breather Cap, Calif. 389 Tri- powers Cars only Painted (RE)..... 20.00/ea.

TRI-POWER AIR CLEANERS

Important Note: The following Tri-Power air cleaner components are correct for some 1965 and all '66 units. We have listed complete sets and components for earlier models for those people who want the three single air cleaner setup.



PN534Y



PN535

- PN534Y** 1964 Valve Cover Oil Breather Cap, Push-On (421 Tri-Power) (Type FC-45 Chrome - Calif.) (RE)..... \$42.00/ea.
- PN535** 1964-67 Valve Cover Oil Breather Cap, Twist-On (Chrome) (APE) 33.00/ea.

PN535 is a chrome-plated reproduction of the original part with the correct double dimples and embossed AC-OIL logo. Quality is excellent.



PN526BE

- PN535BE** 1967-77 Edelbrock Push-in Chrome Breather Cap (AP) 11.00/ea.
- PN535BD** 1964-77 Valve Cover Oil Breather Cap, Push-In (No Script) (AP) 8.00/ea.

Use PN535BD with the PN526GA valve covers. Only one side of PN526GA will accept this breather cap.



PN535BF

- PN535BF** 1955-77 Edelbrock Open-Element Push-in Chrome Breather Cap (AP)..... 30.00/ea.
- PN535BK** 1955-77 Edelbrock Push-in Chrome Valve Cover Plug (AP) 9.00/ea.
- PN535BL** 1955-77 Low-Profile Open-Element Push-in Chrome Breather Cap (AP)..... 15.00/ea.

PN535BL is an unmarked 2" high breather.

- PN535BM** 1955-77 Open-Element Push-in Chrome Breather Cap w/Shield (AP)..... 20.00/ea.

PN535BE through PN535BM include rubber grommets for a 1 1/4" hole.



PN536B



PN536C

- PN536B** 1968-77 Valve Cover Oil Filler Cap (AP)..... 5.50/ea.
This is not the original design cap but is a zinc plated after-product replacement.
- PN536C** 1967-77 Chrome Valve Cover Oil Filler Cap - All (RE)..... 15.00/ea.

PN536C is a chrome reproduction with a Stant® "S" stamped on the rivet. Not a correct style for Pontiacs but looks good and works well. Chrome quality is fair.



- PN100** 1957-58 Tri-Power Air Cleaners, Complete w/GM A220C Paper Elements (RE) \$119.00/set



- PN101** 1959-65 Tri-Power Air Cleaners, Complete w/GM A220C Paper Elements (RE) 119.00/set



- PN102** 1966 Tri-Power Air Cleaners, Complete w/GM A220C Paper Elements (RE) 119.00/set

PN101



- PN103** 1957-58 Tri-Power Air Cleaners, Complete w/Reproduction A193C Foam Elements and Screens (RE) 169.00/set



- PN104** 1959-65 Tri-Power Air Cleaners, Complete w/Reproduction A193C Foam Elements and Screens (RE) 169.00/set



- PN105** 1966 Tri-Power Air Cleaners, Complete w/Reproduction A193C Foam Elements and Screens (RE) 169.00/set

PN104

- PN105P** 1959-65 Tri-Power Air Cleaners, Complete - California Only w/GM A220C Paper Elements (RE) 195.00/set

- PN105S** 1959-65 Tri-Power Air Cleaners, Complete - California Only w/Reproduction A193C Foam Elements and Screens (RE) 239.00/set



- PN105T** 1964-66 Tri-Power Chrome Air Cleaners w/ K&N Filter Kit (AP) 155.00/set



- PN105U** 1957-58 Tri-Power Chrome Air Cleaners w/ K&N Filter Elements (RE/AP) 189.00/set



- PN105V** 1964-65 Tri-Power Chrome Air Cleaners w/ K&N Filter Elements (RE/AP) 179.00/set

- PN105W** 1966 Tri-Power Chrome Air Cleaners w/ K&N Filter Elements (RE/AP) 179.00/set

PN105T

Note: PN105T is a K & N kit with afterproduct bases and lids.

PN105V

Note 1: PN101 through PN105W come complete with 3 lids, 3 bases, and 3 elements. See PN212 and PN214 for wing nuts and carb studs.

Comments: Excellent.

ENGINE COMPONENTS



PN106

- PN106** 1957-66 Tri-Power Chrome Cover (RE) \$20.00/ea.
- PN107** 1957-58 Tri-Power Air Cleaner Base, Small - All (RE) 15.00/ea.
- PN107** 1959-65 Tri-Power Air Cleaner Base, Center, Small (RE) 15.00/ea.
- PN108** 1959-66 Tri-Power Air Cleaner Base, Large, 1959-65 End, 1966 All (RE) 15.00/ea.



PN108K

- PN108K** 1959-65 Tri-Power Air Cleaner Bases, California Only (Set of 3) (RE) 130.00/set
- PN109** 1957-66 Tri-Power Paper Air Cleaner Elements A220C (Set of 3) (GM)..... 25.00/set
- PN109B** 1957-58 Tri-Power Lids & Bases Only (RE) 99.00/set
- PN110** 1959-65 Tri-Power Lids & Bases Only (RE) 95.00/set
- PN111** 1966 Tri-Power Lids & Bases Only (RE) 95.00/set



PN112

- PN112** 1957-66 Tri-Power Foam Air Cleaner Elements A193C (*Note: NOS is used in photo*) (Set of 3) (RE) 39.00/set

Although this foam does not have the AC logo it does have the correct cell structure and is embossed with the A193C imprint. The only other difference between these and originals is they are manufactured without the thin inner lip around the top and bottom. This is not noticeable when the air cleaners are assembled.

Comments: Good.



PN113

- PN113** 1957-66 Tri-Power Air Cleaner Screens for use w/Foam Elements (*Note: NOS is used in photo*) (Set of 3) (RE) 39.00/set

These screens are used with the PN112 foam elements to complete the air cleaner assembly.

Comments: Very close to original. We are using similar steel and original style fine wire screen to keep large particles from piercing the foam and entering the engine.

AIR FILTER ELEMENTS



PN349X

- PN349X** 1957-65 Air Filter Element, 3-2 bbl (AP)..... \$22.00/ea.
This is the large filter for the original 1-piece air cleaner for Tri-Powers.
- PN350** 1958-67 Air Filter Element, 2 bbl and 4bbl, Exc. Calif (AP) 14.00/ea.
- PN351** 1959-60 Air Filter Element, 2 bbl Heavy Duty (GM) 14.00/ea.
- PN352** 1965-67 Air Filter Element, 2+2 4bbl exc. HO (GM)..... 14.00/ea.
- PN355** 1965-67 Air Filter Foam Element, 2+2 4bbl (RE) 36.00/ea.
Note: To be used with an original screen.
- PN356** 1967 Air Filter Element, 428 4bbl - Std. (GM) 16.00/ea.
- PN357** 1967 Air Filter Element, 428 4bbl - HD (GM) 15.00/ea.
- PN356** 1967 Air Filter Element, 428 4bbl - HO (GM) 16.00/ea.
- PN356** 1968-75 Air Filter Element - 4 bbl exc. HD (GM) 16.00/ea.
- PN357** 1968-75 Air Filter Element - 4 bbl - HD (GM)..... 15.00/ea.
- PN359** 1967-76 Air Filter Element - 2 bbl - All (GM) 11.00/ea.
- PN356** 1976 Air Filter Element - 4 bbl - FS (GM)..... 16.00/ea.
- PN357** 1976 Air Filter Element - 4 bbl - GP (GM)..... 15.00/ea.
- PN356** 1977 Air Filter Element w/350R, 403 GP (GM) 16.00/ea.
- PN357** 1977 Air Filter Element w/350P, 400 GP (GM) 15.00/ea.
- PN360** 1977 Air Filter Element w/301 (GM) 12.00/ea.

K & N AIR FILTER ELEMENTS



PN365

- PN365** 1957-66 Tri-Power Air Filter Element Set (AP)..... 93.00/set
Note: Set of 3.
- PN365D** 1967 Air Filter Element, 428 4BBL Std & HO (AP) 52.00/ea.
- PN365G** 1968-75 Air Filter Element, 4BBL exc. HD (AP).. 52.00/ea.
- PN365G** 1976 Air Filter Element, 4BBL - FS (AP) 52.00/ea.
- PN365G** 1977 Air Filter Element, w/ 350R, 403 GP (AP) 52.00/ea.

Get the ultimate in air intake capabilities. These filters can add up to 4-5 HP and they never need replacing. They can be cleaned and recharged using PN365M.



PN365M

- PN365M** K & N Air Filter Recharge Kit (AP)..... 16.00/kit

AIR CLEANERS & COMPONENTS



PN370

PN370 1965-66 Air Cleaner Assembly, 2+2 and 421 4bbl (RE) \$269.00/ea.

Note: This is the chrome-louvered air cleaner with 4" hole for the Carter AFB carburetor. It includes paper air cleaner element.

PN370N 1967 4 bbl Louvered Air Cleaner Assembly (RE)..... 174.00/ea.

Note: This is the chrome-louvered air cleaner with 5" hole for the Rochester Quadrajets carburetor. It includes an AC paper element. See page 124 for replacement foam or paper filters.

PN370R 1965-67 Louvered Air Cleaner Chrome Lid (RE). 129.00/ea.

Note: This is the chrome lid only.

PN370T 1967 Louvered Air Cleaner Base for Quadrajets Carburetor (RE) 59.00/ea.



PN371



PN373

PN371 1967 Air Cleaner Assembly, 428 HO (RE)..... 65.00/ea.

Note: This reproduction assembly consists of chrome cover, aluminum base, and paper element.

PN372 1967 Air Cleaner Cover (APE) 42.00/ea.

Note: PN372 consists of chrome air cleaner cover only (14" OD).

PN373 1967-75 Air Cleaner Cover 17" OD - Chrome (RP) 55.00/ea.

This is a replacement and is not an exact match to originals which have a small circular groove (arrow indicates where the groove would be located).

Comments: Chrome is considered good.



PN374B

PN374 1967-75 Air Cleaner Cover 17" OD - Chrome (RP) 65.00/ea.

More correct than PN373. However, groove is too shallow.

Comments: Chrome plating on this cover is fair.

PN374B 1969-72 Dual Snorkel Air Cleaner w/Lid (RE)..... 249.00/ea.



PN377



PN379

PN377 1959-77 Air Cleaner Lid Gasket (RP)..... 8.00/ea.

Certain years and applications do not require this gasket.

PN379 1957-58 Front, Center, and Rear Tri-Power Carb to Air Cleaner Gasket (AP) 2.50/ea.

PN379 1959-65 Center Tri-Power Carb to Air Cleaner Gasket (AP) 2.50/ea.

PN379A 1959-65 Front & Rear Tri-Power Carb to Air Cleaner Gasket (AP) 2.50/ea.

PN379AJ 1959-66 Carb to Air Cleaner Gasket - AFB Four-Barrel 4" Base (AP) 2.50/ea.

PN379A 1966 Front, Center, and Rear Tri-Power Carb to Air Cleaner Gasket (AP) \$2.50/ea.

PN379AM 1967-77 Carb to Air Cleaner Gasket - Quadrajets Four-Barrel 5" Base (AP) 2.50/ea.

PN379AQ 1959-66 Air Cleaner Adapter, 5 1/8" Air Cleaner Neck to 4 7/32" Carb Neck 5.00/ea.



PN212

PN212 1957-66 Tri-Power Wing Nuts (Set of 3) (RE) 5.50/set

PN213 4-Barrel Wing Nut (RE) 2.50/ea.

Nuts are stamped steel and chrome-plated like original.

PN214 Tri-Power Carburetor Studs (Set of 3) (RE) 8.00/set
Studs have correct thread and length to be used with PN100 through PN105W.



PN214



PN214A

PN214A Air Cleaner Carb Stud (GM)..... 6.00/ea.

This universal stud is 9 inches long and must be cut for your particular application.



PN345L

PN345K 1957-65 Air Horn Repair Kit 1957-58 All Carbs & '59-'65 Tri-Power Center Carb Only (RP) Disc.

PN345L 1959-66 Air Horn Repair Kit - 1959-65 Tri-Power End Carbs, 1966 Center and End Carbs 11.00/ea.

Note: These air horn repair kits are stamped replacements. They are not like original but will allow you to save tri-power carburetors with broken air horns.



PN487J

PN487J 1968-72 Air Inlet Thermal Vacuum Sensor (RP).. 22.00/ea.

PN487K 1973-77 Air Inlet Thermal Vacuum Sensor (RP). 22.00/ea.



PN487LW

Note: These are the cold-start sensors usually mounted on the air cleaner base. They regulate the amount of exhaust manifold preheated air allowed to the engine during warm-up.

PN487LC 1968 4bbl Air Cleaner Vacuum Hose Kit - All (RE) 3.50/ea.

PN487LW 1969-72 4bbl Dual Snorkel Air Cleaner Vacuum Hose Kit (RE) 6.00/ea.

These kits have the correct white striped vacuum hoses. Addition of these correct-style hoses is a great way to complement the engine compartment.



PN388

PN388 1970-72 Pre-heater Diaphragms, All 4 bbl w/Dual Snorkel Air Cleaner (RE) 59.00/kit

PN388 comes complete with diaphragms, brackets, and attaching rivets. Brackets come un-marked.

TRI-POWER FUEL LINES



		PN118A	
PN114	1957	Tri-Power Fuel Lines (RE)	\$32.00/set
PN114A	1958	Tri-Power Fuel Lines (Steel) w/4-Way Fuel Block and 3- 90° Fittings (RE)	55.00/set
PN115	1959-60	Tri-Power Fuel Lines (Steel) w/4-Way Fuel Block and 3- 90° Fittings (RE)	55.00/set
PN115A	1959-60	Tri-Power Fuel Lines (Steel) w/4-Way Fuel Block, Front and Rear 105° Fittings and 90° Center Fittings (RE)	69.00/set
PN116	1961-62	Tri-Power Fuel Lines (Aluminum) w/4-Way Fuel Block and 3- 90° Fittings (RE)	65.00/set
PN116A	1961-62	Tri-Power Fuel Lines (Aluminum) w/4-Way Fuel Block, Front and Rear 105° Fittings and 90° Center Fitting (RE).....	77.00/set
PN117	1963	Tri-Power Fuel Lines (Aircraft Aluminum) w/4-Way Fuel Block and 3- 90° Fittings (RE)	58.00/set
PN117A	1963	Tri-Power Fuel Lines (Aircraft Aluminum) w/4-Way Fuel Block, Center and Rear 90° Fittings and Front 105° Fitting (RE)	65.00/set
PN118	1964-65	Tri-Power Fuel Lines w/3-Way Fuel Block, Center 45° Fitting and Rear 90° Fitting (RE)	48.00/set
PN118A	1964-65	Tri-Power Fuel Lines w/3-Way Fuel Block, Center 45° Fitting and Rear 105° Fitting (RE)	55.00/set
PN119	1966	Tri-Power Fuel Lines w/Front Carb. Fuel Block, Center and Rear 90° Fittings - 1st design with Long Feed Line (RE)	48.00/set
PN119A	1966	Tri-Power Fuel Lines w/Front Carb. Fuel Block, Center and Rear 105° Fittings - 1st design with Long Feed Line (RE)	62.00/set
PN119AA	1966	Tri-Power Fuel Lines w/Front Carb. Fuel Block, Center and Rear 90° Fittings - 2nd Design w/Short Feed Line (APE)	48.00/set
PN119AB	1966	Tri-Power Fuel Lines w/Front Carb. Fuel Block, Center and Rear 105° Fittings - 2nd Design w/Short Feed Line (APE)	62.00/set
PN119AR	1959-66	Tri-Power Fuel Lines w/Front Carb. Fuel Block, Center and Rear Fittings (RE).....	30.00/set

PN119AR is made to be used with aftermarket replacement Tri-Power carbs (PN457B) found on page 130.

All fuel line kits use the original design fuel blocks (made by Weatherhead and authentic down to the logo). The N120 and N121 kits use the Weatherhead replacement 90° fitting where applicable. This is the same fitting we've used satisfactorily for years. For the serious restorer we offer the N120A, N121A and N122A kits which have the correct 105° fitting.

Comments: Excellent.

PN123	1958	Tri-Power Fuel Lines w/o Fittings (RE) ...	36.00/set
PN124	1959-60	Tri-Power Fuel Lines w/o Fittings (RE) ...	36.00/set
PN125	1961-62	Tri-Power Fuel Lines w/o Fittings (RE) ...	36.00/set
PN125A	1963	Tri-Power Fuel Lines w/o Fittings (RE) ...	36.00/set
PN126	1964-65	Tri-Power Fuel Lines w/o Front Carb. Fuel Block but w/45° and 90° Fittings (RE) ...	35.00/set
PN127	1966	Tri-Power Fuel Lines w/o Front Carb. Fuel Block but w/Two 90° Fittings (RE) .	35.00/set

TRI-POWER FUEL LINE FITTINGS



PN128

PN128 1966 Tri-Power Center Carb. Fitting (RE)..... \$16.00/ea.
This is an inexpensive way to save your center carb when the fitting threads become stripped.



PN135



PN136

PN133	1958-60	Tri-Power 4-Way Fuel Block (Weatherhead).....	33.00/ea.
PN134	1961-63	Tri-Power 4-Way Fuel Block (Weatherhead).....	33.00/ea.
PN135	1964-66	Tri-Power Fuel Block (Weatherhead).....	21.00/ea.
PN136	1958-66	Fuel Line Fitting—105° (Weatherhead).....	11.00/ea.
PN137	1959-66	Fuel Line Fitting—90° (Weatherhead).....	2.50/ea.
PN138	1964-65	Fuel Line Fitting—45° (Weatherhead).....	2.50/ea.

2-BBL, 4-BBL & 2/4 - BBL FUEL LINES



PN155

PN139T	1955-56	4-Barrel Fuel Line (RE).....	Disc.
PN141	1957	Bonneville Fuel Line - FI (RE)	Disc.
PN142	1957	4-Barrel Fuel Line - 2 pc. (RE).....	Disc.
PN147	1961	2-Barrel Fuel Line (RE).....	23.00/ea.
PN148	1961-62	4-Barrel Fuel Line (RE).....	23.00/ea.
PN148C	1962	SD 2- 4-Barrel Fuel Line Set w/ Replacement Brass "T" (RE)	29.00/set
PN148D	1962	SD 2- 4-Barrel Fuel Line Set w/ Original Style Brass "T" (RE).....	69.00/set
PN149C	1963	SD 2- 4-Barrel Fuel Line Set w/ Replacement Brass "T" (RE)	29.00/set
PN149D	1963	SD 2- 4-Barrel Fuel Line Set w/ Original Style Brass "T" (RE).....	55.00/set
PN150	1964	4-Barrel Fuel Line (RE).....	15.00/ea.
PN151	1965	4-Barrel Fuel Line (RE).....	15.00/ea.
PN152	1966	4-Barrel Fuel Line (RE).....	10.00/ea.
PN154	1967	2-Barrel Fuel Line (RE).....	23.00/ea.
PN154D	1967	Carter AFB 4-Barrel Fuel Line (RE).....	23.00/ea.
PN155	1967	Rochester 4-Barrel Fuel Line w/o AC or 428 (RE).....	23.00/ea.
PN156	1967	Rochester 4-Barrel Fuel Line w/AC or 428 (RE)	45.00/ea.
PN159	1968-72	2-Barrel Fuel Line (RE).....	23.00/ea.
PN160	1968	4-Barrel Fuel Line (RE).....	23.00/ea.
PN163	1969-70	4-Barrel Fuel Line (RE).....	23.00/ea.

This line runs past the thermostat housing on the driver's side and is compatible with bottom outlet fuel pumps.

PN164 1969-70 4-Barrel Fuel Line (RE)..... 23.00/ea.
This line runs past the thermostat housing on the passenger's side and is compatible with bottom outlet fuel pumps.

Fuel lines continue on next page.

Fuel lines continued.



PN171

- PN165** 1970 4-Barrel Fuel Line (RE)..... \$23.00/ea.
This line runs past the thermostat housing on the driver's side and is compatible with side outlet fuel pumps.
- PN165K** 1970 4-Barrel Fuel Line (RE)..... 23.00/ea.
This line runs past the thermostat housing on the passenger's side and is compatible with side outlet fuel pumps.
- PN166** 1970-74 4-Barrel Fuel Line Pontiac V8 (RE) 23.00/ea.
This line is usually associated with standard horsepower engines. It runs up the driver's side, then over and has a 5 1/2" straight into the front of the carburetor. It is compatible with side outlet fuel pumps.
- PN170** 1971-74 4-Barrel Fuel Line Pontiac V8 (RE) 23.00/ea.
This fuel line enters into the front of the bowl on the carburetor.
- PN171** 1975-77 4-Barrel Fuel Line w/o Foam Cover Pontiac V8..... 23.00/ea.

FUEL PUMPS & COMPONENTS



PN173MA



PN173MC

- PN173MA** 1959-66 Brass Fuel Pump 90° Fitting (RP) 5.50/ea.
- PN173MC** 1959-65 Brass Fuel Pump Inlet Fitting, Straight (RE) 6.50/ea.
- PN173PD** 1959-65 Fuel Pump - All exc. '65 w/421 (AC-Delco) 82.00/ea.
- PN173PG** 1966 Fuel Pump - All & '65 421 (AC-Delco) 34.00/ea.
- PN173PJ** 1967 Fuel Pump - 400 w/o AC (AC-Delco) 34.00/ea.
- PN173PK** 1967 Fuel Pump - 400 w/AC or 428 (AC-Delco) 42.00/ea.
- PN173PN** 1968 Fuel Pump - 400 w/Vapor Return (AC-Delco) 36.00/ea.
- PN173PP** 1969 Fuel Pump w/o Vapor Return (AC-Delco) 49.00/ea.
- PN173PR** 1969 Fuel Pump w/Vapor Return (AC-Delco) 36.00/ea.
- PN173PR** 1970 Fuel Pump - GP, 2 BBL (AC-Delco) 36.00/ea.

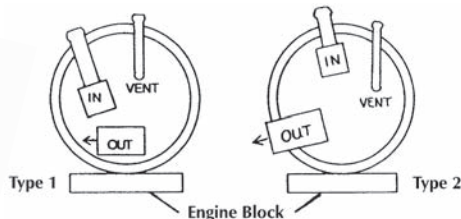

- PN173PT** 1970 Fuel Pump - GP, 4 BBL w/Vapor Return, 1st Design (AP)..... 36.00/ea.
- PN173PV** 1970 Fuel Pump - GP, 4bbl w/Vapor Return, 2nd Design (AC-Delco) 41.00/ea.
- PN173PZ** 1971 Fuel Pump, 4bbl w/AC (AP)..... 37.00/ea.
- PN173RC** 1972-74 Fuel Pump, 4bbl w/AC (AC-Delco) 47.00/ea.
- PN173RF** 1973 Fuel Pump, 2bbl w/AC (AC-Delco) 29.00/ea.



PN173TD

- PN173TD** 1959-77 High Performance Fuel Pump (AP) \$109.00/ea.
This chrome-plated fuel pump delivers up to 80 gallons per hour at 8 psi. Stock is 55 gallons per hour at 6 1/2 psi. This pump uses a rubber hose outlet line to the carburetor unlike most steel lines used on originals.
Comes with fittings and gasket.



- PN174BP** Fuel Pump Block Off Plate, Chrome (AP) 8.00/ea.
 - PN174BE** 1959-77 Fuel Pump Gasket (RE) 2.00/ea.
These gaskets are included with our new fuel pumps.
 - PN174BG** 1963-67 Fuel Pump to Timing Chain Cover Bolt Kit with Correct 12 Point Heads, 5/16" All V8 (RP) 7.00/kit
 - PN174BJ** 1964-67 Fuel Pump to Timing Chain Cover 3/8" Bolt Kit, All V8 (RP)..... 6.00/kit
- It appears that both 5/16" and 3/8" bolts were used from 1964-67. Please check bolt size before ordering.

- PN174BN** 1968-77 Fuel Pump to Timing Chain Cover Bolt Kit, All V8 (RP) 3.00/kit
- Note: PN174BG through PN174BN are replacement bolts that will not have the same markings as original.

RUBBER FUEL HOSE



PN174DB

- PN174DB** "Gas, Gas" Printed Rubber Fuel Hose, 3/8" (RE) 4.00/ft
This is the correct printed fuel/pcv hose used on various years.
- PN174DF** Replacement 1/4" Runner Fuel Hose (AP) 1.50/ft
- PN174DJ** Replacement 5/16" Rubber Fuel Hose (AP) 1.50/ft
- PN174DK** Replacement 3/8" Rubber Fuel Hose (AP) 1.50/ft

VACUUM AND FUEL LINE CLAMPS



- PN175K** 3/8" OD Hose Clamp (Black)(AP)75/ea.
- PN175L** 7/16" OD Hose Clamp (Green)(AP)75/ea.
- PN175M** 1/2" OD Hose Clamp (Red)(AP)..... .75/ea.
- PN175N** 9/16" OD Hose Clamp (Black)(AP)75/ea.
- PN175P** 5/8" OD Hose Clamp (Green)(AP)75/ea.
- PN175R** 11/16" OD Hose Clamp (Red)(AP)75/ea.
- PN175S** 3/4" OD Hose Clamp (Black)(AP)75/ea.

When ordering hose clamps, please be aware that the sizes are based on the hose **outside diameter**. For Example, if you have a 3/8" fuel hose, the ID is 3/8" and the wall thickness is 1/8". Therefore, you will need a 5/8" OD hose clamp for this application.

FRONT TO REAR FUEL LINES AND RETURN LINES

These lines are considered the best in the industry. All Lines are drop-shipped directly from the supplier and must be prepaid.

Stainless steel lines are made from high-quality 304 stainless.

Please add \$20.00 for shipping on front to rear lines.

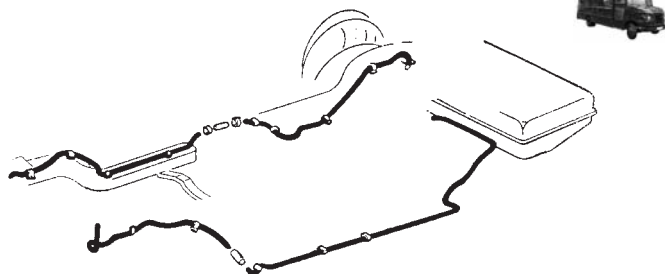

PN176B	1955-57	Front to Rear Fuel Line 3/8" 122" WB, Steel (RE)	\$68.00/ea.
PN176BS	1955-57	Front to Rear Fuel Line 3/8" 122" WB, Stainless Steel (RE).....	92.00/ea.
PN176C	1955-57	Front to Rear Fuel Line 5/16" 122" WB, Steel (RE)	68.00/ea.
PN176CS	1955-57	Front to Rear Fuel Line 5/16" 122" WB, Stainless Steel (RE).....	92.00/ea.
PN176D	1955-57	Front to Rear Fuel Line 3/8" 124" WB, Steel (RE)	68.00/ea.
PN176DS	1955-57	Front to Rear Fuel Line 3/8" 124" WB, Stainless Steel (RE).....	92.00/ea.
PN176E	1955-57	Front to Rear Fuel Line 5/16" 124" WB, Steel (RE)	68.00/ea.
PN176ES	1955-57	Front to Rear Fuel Line 5/16" 124" WB, Stainless Steel (RE).....	88.00/ea.
PN176F	1958	Front to Rear Fuel Line 3/8" Steel (RE) ...	68.00/ea.
PN176FS	1958	Front to Rear Fuel Line 3/8" Stainless Steel (RE).....	88.00/ea.
PN176G	1958	Front to Rear Fuel Line 5/16" Steel (RE) .	68.00/ea.
PN176GS	1958	Front to Rear Fuel Line 5/16" Stainless Steel (RE).....	88.00/ea.
PN176H	1959-60	Front to Rear Fuel Line 3/8" 124" WB, Steel (RE)	68.00/ea.
PN176HS	1959-60	Front to Rear Fuel Line 3/8" 124" WB, Stainless Steel (RE).....	88.00/ea.
PN176J	1959-60	Front to Rear Fuel Line 5/16" 124" WB, Steel (RE)	68.00/ea.
PN176JS	1959-60	Front to Rear Fuel Line 5/16" 124" WB, Stainless Steel (RE).....	92.00/ea.
PN177JA	1961-62	Front to Rear Fuel Line - Cat/GP 3/8" Steel (RE).....	68.00/ea.
PN177JB	1961-62	Front to Rear Fuel Line - Cat/GP 3/8" Stainless Steel (RE)	92.00/ea.
PN177JE	1961-62	Front to Rear Fuel Line - Ventura 3/8" Steel (RE).....	68.00/ea.
PN177JF	1961-62	Front to Rear Fuel Line - Ventura 3/8" Stainless Steel (RE)	92.00/ea.
PN177JJ	1961-62	Front to Rear Fuel Line - Bonne 3/8" Steel (RE).....	68.00/ea.
PN177JK	1961-62	Front to Rear Fuel Line - Bonne 3/8" Stainless Steel (RE)	92.00/ea.
Note: On 1961-62 applications, please specify automatic or manual transmission.			
PN177JN	1963-64	Front to Rear Fuel Line - Cat/GP 3/8" Steel (RE).....	70.00/ea.
PN177JP	1963-64	Front to Rear Fuel Line - Cat/GP 3/8" Stainless Steel (RE)	92.00/ea.
PN177JQ	1963-64	Return Line - Cat/GP - 1/4" Steel (RE)	68.00/ea.
PN177JR	1963-64	Return Line - Cat/GP - 1/4" Stainless Steel (RE)	102.00/ea.
PN177JV	1963-64	Front to Rear Fuel Line - Bonne 3/8" Steel (RE).....	68.00/ea.

PN177JW	1963-64	Front to Rear Fuel Line - Bonne 3/8" Stainless Steel (RE)	\$102.00/ea.
PN177JX	1963-64	Return Line - Bonne 1/4" Steel (RE)	68.00/ea.
PN177JY	1963-64	Return Line - Bonne 1/4" Stainless Steel (RE)	102.00/ea.
PN177KE	1965-66	Front to Rear Fuel Line - Cat/GP 3/8" Steel (RE).....	68.00/ea.
PN177KF	1965-66	Front to Rear Fuel Line - Cat/GP 3/8" Stainless Steel (RE)	102.00/ea.
PN177KG	1965-66	Return Line - Cat/GP 1/4" Steel (RE).....	68.00/ea.
PN177KH	1965-66	Return Line - Cat/GP 1/4" Stainless Steel (RE)	102.00/ea.
PN177KJ	1965-66	Front to Rear Fuel Line - Bonne 3/8" Steel (RE).....	68.00/ea.
PN177KK	1965-66	Front to Rear Fuel Line - Bonne 3/8" Stainless Steel (RE)	102.00/ea.
PN177KM	1965-66	Return Line - Bonne 1/4" Steel (RE).....	68.00/ea.
PN177KN	1965-66	Return Line - Bonne 1/4" Stainless Steel(RE).....	102.00/ea.
PN177KQ	1967-68	Front to Rear Fuel Line - Cat 3/8" Steel (RE).....	68.00/ea.
PN177KR	1967-68	Front to Rear Fuel Line - Cat 3/8" Stainless Steel (RE)	102.00/ea.
PN177KS	1967-68	Return Line - Cat 1/4" Steel (RE).....	68.00/ea.
PN177KT	1967-68	Return Line - Cat 1/4" Stainless Steel (RE)	102.00/ea.
PN177KV	1967-68	Front to Rear Fuel Line - GP 3/8" Steel (RE).....	68.00/ea.
PN177KW	1967-68....	Front to Rear Fuel Line - GP 3/8" Stainless Steel (RE)	102.00/ea.
PN177KX	1967-68	Return Line - Cat 1/4" Steel (RE).....	68.00/ea.
PN177KY	1967-68	Return Line - Cat 1/4" Stainless Steel (RE)	102.00/ea.
PN177LC	1967-68	Front to Rear Fuel Line - Bonne 3/8" Steel (RE).....	68.00/ea.
PN177LD	1967-68	Front to Rear Fuel Line - Bonne 3/8" Stainless Steel (RE)	102.00/ea.
PN177LE	1967-68	Return Line - Bonne 1/4" Steel (RE).....	68.00/ea.
PN177LF	1967-68	Return Line - Bonne 1/4" Stainless Steel(RE).....	102.00/ea.
PN177LL	1969	Front to Rear Fuel Line - GP 3/8" Steel (RE).....	68.00/ea.
PN177LM	1969	Front to Rear Fuel Line - GP 3/8" Stainless Steel (RE)	102.00/ea.
PN177LN	1969	Return Line - GP - 1/4" Steel (RE)	68.00/ea.
PN177LP	1969	Return Line - GP 1/4" Stainless Steel (RE)	102.00/ea.
PN177LSC	1970	Front to Rear Fuel Line 3/8" Steel - FS...	68.00/ea.
PN177LSF	1970	Front to Rear Fuel Line 3/8" Stainless Steel - FS.....	102.00/ea.
PN177LSG	1970	Front to Rear Return Line 1/4" Steel - FS	68.00/ea.
PN177LSH	1970	Front to Rear Return Line 1/4" Stainless Steel - FS.....	102.00/ea.
PN177LS	1970-72	Front to Rear Fuel Line - GP 3/8" Steel (RE).....	68.00/ea.
PN177LT	1970-72	Front to Rear Fuel Line - GP 3/8" Stainless Steel (RE)	102.00/ea.
PN177LV	1970-72	Return Line - GP - 1/4" Steel (RE)	68.00/ea.
PN177LW	1970-72	Return Line - GP 1/4" Stainless Steel (RE)	102.00/ea.
PN177ME	1971-72	Front to Rear Vapor Line - GP w/ EES - 5/16" Steel (RE)	68.00/ea.
PN177MF	1971-72	Front to Rear Vapor Line - GP w/ EES - 5/16" Stainless Steel (RE) .	102.00/ea.
PN177MJ	1971-72	Emission Tank Line Set (3 pc set) - GP w/ EES Steel (RE)	30.00/set

Fuel and Return Lines continue on the next page.

www.amesperf.com

Fuel and Return Lines continued.

PN177MK	1971-72 Emission Tank Line Set (3 pc set) - GP w/ EES Stainless Steel (RE)	\$37.00/set
PN177NJ	1973-77 Front to Rear Fuel Line - GP 3/8" Steel (RE)	68.00/ea.
PN177NK	1973-77 Front to Rear Fuel Line - GP 3/8" Stainless Steel (RE)	102.00/ea.
PN177NL	1973-77 Return Line - GP 1/4" Steel (RE)	68.00/ea.
PN177NM	1973-77 Return Line - GP 1/4" Stainless Steel (RE)	102.00/ea.
PN177NN	1973-77 Front to Rear Vapor Line - GP 5/16" Steel (RE)	68.00/ea.
PN177NP	1973-77 Front to Rear Vapor Line - GP 5/16" Stainless Steel (RE)	102.00/ea.

FUEL LINE TUBING



PN278	1955-77 3/8" Steel Fuel Line Tubing (25 ft. roll) (AP)	29.00/ea.
PN280	1955-77 5/16" Steel Fuel Line Tubing (25 ft. roll) (AP)	22.00/ea.
PN282	1961-77 1/4" Steel Vapor Return Tubing (25 ft. roll) (AP)	20.00/ea.
PN282J	1964-77 3/8" Stainless Steel Fuel Line Tubing Armor (4 ft. section) (AP)	15.00/ea.
PN282L	1964-77 5/16" Stainless Steel Fuel Line Tubing Armor (4 ft. section) (AP)	15.00/ea.
PN282N	1964-77 1/4" Stainless Steel Fuel Line Tubing Armor (4 ft. section) (AP)	15.00/ea.

FUEL LINE CLIPS

The following replacement fuel line clips may or may not be an exact replacement for your originals.



PN179S	Steel Line Clip, Double Line Fits 1/4" and 3/8" Lines (AP)	2.00/ea.
PN179SB	Steel Line Clip, Fits 1/4" and 5/16" Lines (Black) (GM)	2.00/ea.
PN179SD	Steel Line Clip, Fits 5/16" and 5/16" Lines (Black) (AP)	2.00/ea.
PN179SF	Steel Line Clip, Fits 1/4" and 3/8" Lines (AP)	2.00/ea.
PN179SH	Steel Line Clip, Fits Single 3/16" Line (Silver) (3/16" Bolt Hole) (AP)	2.00/ea.
PN179SJ	Steel Line Clip, Fits Single 1/4" Line (Silver) (1/4" Bolt Hole) (AP)	2.00/ea.



PN179SL	Steel Line Clip, Fits Single 5/16" Line (Silver) (3/16" Bolt Hole) (AP)	2.00/ea.
PN179SN	Steel Line Clip, Fits Single 3/8" Line (Silver) (3/16" Bolt Hole) (AP)	2.00/ea.
PN179SP	Steel Line Clip w/ Tab, Fits Single 1/4" Line (Blue) (5/32" Bolt Hole) (AP) ...	4.00/ea.



PN179SX	Steel Line Clip w/ Tab, Fits Single 3/8" Line (Blue) (5/16" Bolt Hole) (AP) ...	\$2.00/ea.
PN179SV	Steel Line Clip w/ Tab, Fits Single 3/16" Line (Yellow Zinc) (5/32" Bolt Hole) (AP)	3.00/ea.



PN179TD	Steel Line Clip, Double Line, Fits 3/8" and 1/4" Lines (Silver) (5/16" Bolt Hole) (GM)	4.00/ea.
PN179TB	Steel Line Clip, Double Line, Fits 3/16" and 1/4" Lines (Silver) (5/16" Bolt Hole) (GM)	4.00/ea.
PN179TD	Steel Line Clip, Fits 5/8" Single Line (Silver) (5/32" Bolt Hole) (AP)	2.00/ea.
PN179TF	Steel Line Clip w/ Tab, Fits 3/8" Single Line (Blue) (5/32" Bolt Hole) (AP)	3.00/ea.

FUEL FILTERS & BRACKETS



PN180	1955-57 Fuel Filter w/o FI w/5/16" Fuel Line - Glass-bowl type (RE)	35.00/ea.
PN181	1957-60 Fuel Filter w/o FI w/3/8" Fuel Line, Cad-Plated GF-61-P - All (GM)	8.00/ea.

Note: This replacement filter is not the same shape or size as original. It will not mount tightly in the filter bracket.

PN181A	1957-60 Fuel Filter w/o FI w/3/8" Fuel Line, GF-61-P - All (RE)	35.00/ea.
---------------	--	-----------

Note: This is a reproduction with original-style blue paint and red script.

PN181	1961-66 Fuel Line Filter w/o AC, Cad-Plated GF-61-P - All (GM)	8.00/ea.
--------------	---	----------

Note: This replacement filter is not the same shape or size as original. It will not mount tightly in the filter bracket.

PN181A	1961-66 Fuel Line Filter w/o AC, GF-61-P - All (RE)	35.00/ea.
---------------	--	-----------

Note: This is a reproduction with original style blue paint and red script.

PN184	1961-66 Fuel Line Filter w/AC, Cad-Plated GF-98 - All (GM)	11.00/ea.
--------------	---	-----------

Note: This replacement filter is not the same shape or size as original. It will not mount tightly in the filter bracket.

PN184A	1961-66 Fuel Line Filter w/AC, GF-98 - All (RE)	35.00/ea.
---------------	--	-----------

Note: This is a reproduction with original style blue paint and red script.

PN184	1967 Fuel Line Filter w/428 Cad-Plated GF-98 (GM)	11.00/ea.
--------------	--	-----------

Note: This replacement filter is not the same shape or size as original. It will not mount tightly in the filter bracket.

PN185	1967 Fuel Line Filter w/428 GF-98 (RE)	35.00/ea.
--------------	--	-----------

Note: This is a reproduction with original style blue paint and red script.

ENGINE COMPONENTS



PN191



PN195

- PN190** 1964-66 Fuel Filter, 4 bbl w/o AC (GM) \$4.00/ea.
- PN190** 1967-74 Fuel Filter, 2 bbl w/o AC (GM) 4.00/ea.
- Note: PN190 is for cars equipped with fuel inlet sintered bronze filters.*
- PN191** 1967 Fuel Filter 4bbl w/o AC or HO (GM) 4.00/ea.
- PN192** 1968-74 Fuel Filter, 4 bbl Paper Element (GM) ... 4.00/ea.
- PN194** 1975-77 Fuel Filter, 4 bbl (GM) 5.00/ea.
- PN195** 1964-77 Fuel Filter Spring & Gasket (RP) 1.50/ea.

For applications with fuel filter in carburetor.



PN260



PN262

- PN260** 1961-62 Fuel Filter Bracket (RE)..... 13.00/ea.
- PN260A** 1963-64 Fuel Filter Bracket (RE)..... 13.00/ea.
- PN260B** 1965-66 Fuel Filter Bracket (RE)..... 11.00/ea.

PN260B is not used for 1966 Tri-Power applications. See PN262

- PN260C** 1967 Fuel Filter Bracket (RE)..... 16.00/ea.
- PN262** 1966 Tri-Power Fuel Filter Bracket, Zinc-Plated (RE) 11.00/ea.

VAPOR CANISTER & FILTER



PN196

- PN196** 1971-77 Vapor Canister (GM-RP)..... 69.00/ea.
- PN196B** 1971-77 Vapor Canister Filter (GM)..... 4.00/ea.

TRI-POWER CARBURETORS

Remanufactured by one of the top rebuilders in the industry, all carburetors are tested to ensure top performance.

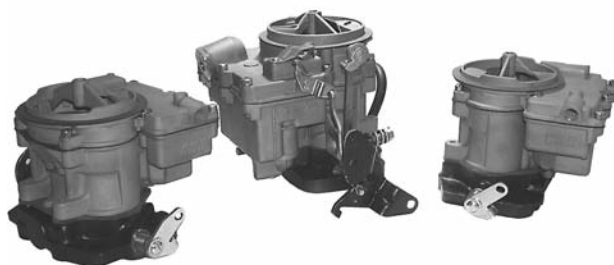

- PN456C** 1959-65 Tri-Power Center Carb (RP)..... Inquire
- PN456D** 1966 Tri-Power Center Carb (RP)..... \$209.00/ea.
PN456C & PN456D exhibit stock appearance
- PN457B** 1959-66 "Replacement" Tri-Power End Carbs (RP) 499.00/pr.
PN457B carbs have front fuel inlets with 90° fittings. Sold in pairs only. See PN119AR on page 126 for **required** fuel supply lines.
- PN457C** 1959-66 "Correct-Style" Tri-Power End Carbs (RP) 789.00/pr.
- PN457CF** 1959-66 "Correct-Style" Tri-Power Front Carb (RP) 399.00/ea.
- PN457CR** 1959-66 "Correct-Style" Tri-Power Rear Carb (RP) 399.00/ea.
PN457C through PN457CR are correct-style carbs with side fuel inlets. Tri-Power carburetors include base gasket & air cleaner gasket.

4-BARREL CARBURETORS



- PN458B** 1957-67 Remanufactured Carter AFB Carburetor (RP) 399.00/ea.
PN458B requires an additional \$75.00 refundable core charge.
 - PN458C** 1967-70 Remanufactured Rochester Quadrajct Carburetor (RP) 399.00/ea.
PN458C requires an additional \$100.00 refundable core charge.
- PN456C through PN458C are remanufactured original carburetors. They will not have original numbers and some components may differ slightly from original. They do, however, exhibit correct plating.



Harry's Tech Tip Ethanol (E10) Information

With Ethanol (E10) fuels being used in most areas, it is important to know that Ames Performance is making every effort to provide the best alcohol-compatible fuel related components. It is also imperative that installers are aware of this need. The most common item in your carburetor to fail is the accelerator pump seal. Most aftermarket kits still use a seal that is not alcohol resistant. We, at Ames, provide a neoprene Viton© seal in all of our rebuild kits. This is just another way that we provide the best parts and customer service in the industry.

When in doubt, call & talk to one of our technicians. We have the knowledge and resources to steer you in the right direction.

1-800-421-2637

AFTERMARKET CARBURETORS

The Performer Series carburetors from Edelbrock feature two-piece all-aluminum construction for cooler fuel and less warpage. There are no gaskets below the fuel bowl level to leak and no plastic parts or power valves to blow out. The primary venturi feature is a bottom-feed design for improved drivability and smooth acceleration. These carbs use easily changeable metering rods for precision-tuning.

All performer carbs are square-flanged; therefore, an **adapter plate (PN458G) must be used** to install on an OEM Quadrajet style intake.

Combine the Performer Series carburetor with other Edelbrock components offered in this section for the Edelbrock "Total Power Package" no guess-work performance.

Edelbrock carburetors are for non-emission vehicles. Intended only for off-road use on 1975-77 cars.

No additional discounts apply to Edelbrock carburetors.



PN458EA	Edelbrock Performer, 600cfm, Manual Choke (AP).....	\$319.00/ea.
PN458EB	Edelbrock Performer, 600cfm, Electric Choke (AP).....	369.00/ea.
PN458EC	Edelbrock Performer, 750cfm, Manual Choke (AP).....	299.00/ea.
PN458ED	Edelbrock Performer, 750cfm, Electric Choke (AP).....	399.00/ea.
PN458EF	Edelbrock Performer, 800cfm, Manual Choke (AP).....	399.00/ea.
PN458EG	Edelbrock Performer, 800cfm, Electric Choke (AP).....	499.00/ea.
PN458G	Edelbrock Carburetor to Stock Quadrajet Manifold Adapter Plate (AP).....	45.00/ea.



PN458J

PN458J	Edelbrock Carburetor Air Cleaner Riser Adapter Plate (AP).....	6.50/ea.
---------------	---	----------

PN458J allows a stock air cleaner base mount on an Edelbrock carb without interfering with linkage, fuel lines etc.

ECHLIN CARB REBUILD KITS



PN460	1955-56 2-Barrel (AP).....	\$28.00/ea.
PN460	1957-65 Tri-Power Center Carb (AP).....	28.00/ea.
PN461	1955 Rochester 4-Barrel (AP).....	29.00/ea.
PN462	1955-56 Carter 4-Barrel (AP).....	38.00/ea.
PN465	1957 Rochester 4-Barrel (AP).....	35.00/ea.
PN466	1957-58 Tri-Power End Carbs (AP).....	21.00/ea.
PN467	1957-58 Carter 4-Barrel (AP).....	33.00/ea.
PN468	1958-69 2-Barrel (AP).....	28.00/ea.
PN468	1959-66 Tri-Power End Carbs (AP).....	28.00/ea.
PN460	1957-65 Tri-Power Center Carb (AP).....	28.00/ea.
PN468	1966 Tri-Power Center Carb (AP).....	28.00/ea.
PN471	1961-65 Carter 4-Barrel (AP).....	43.00/ea.
PN467	1966-67 Carter 4-Barrel (AP).....	33.00/ea.
PN472	1967 Rochester 4-Barrel (AP).....	34.00/ea.
PN473	1968 Rochester 4-Barrel (AP).....	35.00/ea.
PN474	1969-71 Rochester 4-Barrel w/o Ram Air (AP)....	35.00/ea.
PN475	1970-74 Rochester 2-Barrel (AP).....	31.00/ea.
PN476	1972-74 Rochester 4-Barrel exc. Hi Alt (AP).....	27.00/ea.

1975-77 carb kits are also available. Please inquire.

Note: Of the many standard carburetor kits on the market, the Echlin kit is considered the best.

DELUXE CARB REBUILD KITS

These kits, made by "The Carburetor Shop", are more comprehensive than our standard line and come in two styles. The Level 1 kits come complete with all gaskets, pumps, springs, etc. that our standard kits contain. Besides the above, Level 1 two barrel kits include the pump return spring, main jets, the center power valve, and idle screws. In addition to the standard kit, the AFB Level 1 kits include primary jets, vacuum piston and spring, plus idle screws. Quadrajet Level 1 kits additionally have the power piston spring, primary jets and idle screws.

Level 2 carburetor kits contain all components found in Level 1 kits plus all new philister head screws, choke plate screws, and throttle plate screws.

Prices for these kits are:

	Level 1 kits	Level 2 kits
2-Barrel	\$55/kit	\$75/kit
3-2-Barrel	125/3 kits	165/3 kits
4-Barrel-4-GC	60/kit	80/kit
4-Barrel WCFB	55/kit	70/kit
4-Barrel-AFB	60/kit	75/kit
Super-duty	100/kit	130/kit
4-Barrel-Q Jet	60/kit	85/kit

Application, type of carburetor and carb # must be given with order.

These kits are available for '55-'75 cars only.

Note: Tri-Power kits must be ordered in sets of 3.

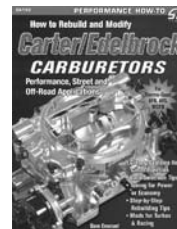

PW134

PW134	<i>Super Tuning and Modifying Carter Carburetors</i> By Dave Emanuel.....	22.00/ea.
--------------	--	-----------



PW135

PW135	<i>Rochester Quadrajet Carburetors</i> by Cliff Ruggles	24.00/ea.
--------------	---	-----------

PW134 and PW135 offer history and a large amount of technical information.

CARBURETOR PLATES & COMPONENTS



PN476DB



PN476DG

PN476DB 1959-66 Tri-Power End Carburetor Top Plate (RE) \$92.00/ea.

PN476DB is a very nice casting with correct gold iridite appearance; however, the "GM" between the "2" and "Jet" is inverted.

PN476DB includes the accelerator pump lever and brass seat.

PN476DE 1959-66 Tri-Power End Carburetor Top Plate Bushing (RE) 2.00/ea.

PN476DG 1959-66 Tri-Power End Carburetor Base Plate (RE) 85.00/ea.

PN476DG includes the shaft with throttle plates, throttle shaft levers, and accelerator rod. Return spring, however, is incorrect and should be replaced. (See PN340J or PN340K). Quality is fair - use as a last resort only.



PN476DK



PN476DN

PN476DK 1959-66 Tri-Power Top Plate Screw Set (RE) 15.00/set

PN476DK contains necessary screws and washers for all 3 carb top plates.

PN476DM Idle Air Vent Seal (RE) 3.00/ea.

This seal is used on Tri-power and 67-70 Q-jet carbs.

PN476DN 1967-77 Quadrajets Secondary Adjust Spring and Screw Set (RE) 9.00/set

PN476DN installs in the carburetor top plate and is used for adjusting the tension on the secondary butterfly.

MIXTURE SCREWS



PN476H

PN476H 1959-65 Idle Mixture Screw, All 2 bbl (RE) 3.00/ea.

PN476J 1966 Idle Mixture Screw, All 2 bbl (RE) 3.00/ea.

PN476K 1967-70 Idle Mixture Screw, All 4 bbl (RE) 3.00/ea.

Note 1: Sold individually, two used per carburetor.

Note 2: Idle Mixture Screws do not include springs.

PN476L Idle Mixture Screw Spring, Tri Power & Q-Jet (RE) 3.00/pr.

CARBURETOR JETS



Note: We do not offer jet sizes other than OEM specifications.

PN476SA 1957-58 Tri-Power End Carb Jets, All (RE) Disc.

PN476SE 1957 Tri-Power Center Carb Jets, All (RE) 7.50/pr.

PN476SD 1958 Tri-Power Center Carb Jets, All (RE) 7.50/pr.

PN476SK 1959-63 Tri-Power End Carb Jets, All Exc. 421 (RE) 7.50/pr.

PN476SJ 1959 Tri-Power Center Carb Jets, AT (RE) 7.50/pr.

PN476SF	1959	Tri-Power Center Carb Jets, MT (RE)	\$7.50/pr.
PN476SG	1960	Tri-Power Center Carb Jets, AT (RE)	7.50/pr.
PN476SD	1960	Tri-Power Center Carb Jets, MT (RE)	7.50/pr.
PN476SF	1961-63	Tri-Power Center Carb Jets, All 389 (RE).....	7.50/pr.
PN476SR	1963	Tri-Power End Carb Jets, All 421 (RE)....	7.50/pr.
PN476SE	1963	Tri-Power Center Carb Jets, 421 AT (RE)	7.50/pr.
PN476SH	1963	Tri-Power Center Carb Jets, 421 MT (RE)	7.50/pr.
PN476SL	1964-66	Tri-Power End Carb Jets, All 389 (RE)....	7.50/pr.
PN476SP	1964	Tri-Power End Carb Jets, All 421 (RE)....	7.50/pr.
PN476SF	1964	Tri-Power Center Carb Jets, 389 & 421 AT (RE).....	7.50/pr.
PN476SH	1964	Tri-Power Center Carb Jets, 389 MT (RE)	7.50/pr.
PN476SJ	1964	Tri-Power Center Carb Jets, 421 MT (RE)	7.50/pr.
PN476SD	1965-66	Tri-Power Center Carb Jets, 389 AT (RE)	7.50/pr.
PN476SG	1965	Tri-Power Center Carb Jets, 389 MT (RE)	7.50/pr.
PN476SF	1966	Tri-Power Center Carb Jets, 389 MT (RE)	7.50/pr.
PN476SR	1965-66	Tri-Power End Carb Jets, All 421 (RE)....	7.50/pr.
PN476SD	1965-66	Tri-Power Center Carb Jets, 421 AT (RE)	7.50/pr.
PN476SE	1965	Tri-Power Center Carb Jets, 421 MT (RE)	7.50/pr.
PN476SF	1966	Tri-Power Center Carb Jets, 421 MT (RE)	7.50/pr.
PN476TB	1967-75	Q-Jet Carb Jets .067,PR (RP).....	7.50/ea.
PN476TD	1967-75	Q-Jet Carb Jets .068,PR (RP).....	7.50/ea.
PN476TF	1967-75	Q-Jet Carb Jets .069,PR (RP).....	7.50/ea.
PN476TH	1967-75	Q-Jet Carb Jets .070,PR (RP).....	7.50/ea.
PN476TJ	1967-75	Q-Jet Carb Jets .071,PR (RP).....	7.50/ea.
PN476TL	1967-75	Q-Jet Carb Jets .072,PR (RP).....	7.50/ea.
PN476TN	1967-75	Q-Jet Carb Jets .073,PR (RP).....	7.50/ea.
PN476TP	1967-75	Q-Jet Carb Jets .074,PR (RP).....	7.50/ea.
PN476TR	1967-75	Q-Jet Carb Jets .075,PR (RP).....	7.50/ea.

QJET METERING RODS & COMPONENTS



PN476VM

PN476VR

PN476VC	Q-Jet .035 Primary Metering Rods, PR .	12.00/ea.
PN476VE	Q-Jet .037 Primary Metering Rods, PR .	12.00/ea.
PN476VG	Q-Jet .039 Primary Metering Rods, PR .	12.00/ea.
PN476VK	Q-Jet .041 Primary Metering Rods, PR .	12.00/ea.
PN476VM	Q-Jet .043 Primary Metering Rods, PR .	12.00/ea.
PN476VP	Q-Jet .045 Primary Metering Rods, PR .	12.00/ea.
PN476VR	Q-Jet Primary Metering Rod Ret Spring,	2.00/ea.
PN476VT	Q-Jet .030 Secondary Metering Rods, PR	12.00/ea.
PN476VV	Q-Jet .041 Secondary Metering Rods, PR	12.00/ea.
PN476VX	Q-Jet .0527 Secondary Metering Rods, PR	12.00/ea.
PN476VY	Q-Jet .0567 Secondary Metering Rods, PR	12.00/ea.
PN476VZ	Q-Jet .0667 Secondary Metering Rods, PR	12.00/ea.



PN476XF



PN476XN

PN476XB	Q-Jet .520" Lift Secondary Metering Rod Hanger	6.00/ea.
PN476XD	Q-Jet .545" Lift Secondary Metering Rod Hanger	6.00/ea.
PN476XF	Q-Jet .565" Lift Secondary Metering Rod Hanger	6.00/ea.
PN476XJ	Q-Jet .590" Lift Secondary Metering Rod Hanger	6.00/ea.
PN476XL	Q-Jet .615" Lift Secondary Metering Rod Hanger	6.00/ea.
PN476XN	1967-77 Q-Jet Secondary Metering Rod Lift Cam.....	4.00/ea.

FLOATS



Note: Floats may differ from original in appearance.

PN477D	1957-65 3x2 Center Carb Float (AP)	\$7.00/ea.
PN477F	1966 3x2 Center Carb Float (AP)	7.00/ea.
PN477H	1959-66 3x2 Front or Rear Carb Float (AP).....	7.00/ea.
PN477M	1957-67 Carter AFB Carb Float (AP)	9.00/ea.

Note: Requires 2 per carb.

PN478B	1967-68 Rochester Q-jet 4 bbl Carb Float (AP)...	7.00/ea.
PN478G	1969-74 Rochester Q-jet 4 bbl Carb Float (AP)...	7.00/ea.
PN478L	1975-77 Rochester Q-jet 4 bbl Carb Float (AP)...	7.00/ea.
PN478R	1964-72 Rochester 2 bbl Carb Float (AP)	7.00/ea.
PN478T	1973-76 Rochester 2 bbl Carb Float (AP)	7.00/ea.

CARBURETOR TO MANIFOLD GASKETS & HARDWARE



PN479AF

PN479AF	1959-66 Tri-Power Outer Carb to Manifold Gasket (RP)	5.00/ea.
PN479AH	1957-65 Tri-Power Center Carb to Manifold Gasket (RP)	5.00/ea.
PN479AF	1966 Tri-Power Center Carb to Manifold Gasket (RP)	5.00/ea.
PN479AL	1957-67 AFB Carb to Manifold Gasket (RP)	13.00/ea.



PN479AN

PN479AN	1967 Q-jet Carb to Manifold Gasket (RP).....	4.50/ea.
PN479AP	1967 Q-jet Carb Baffle, Stainless Steel(RP)..	12.00/ea.
PN479AR	1968-74 Q-jet Carb to Manifold Gasket (RP).....	7.00/ea.
PN479AT	1975-77 Q-jet Carb to Manifold Gasket (RP).....	12.00/ea.

Note: Carburetor rebuild kits come with carb to manifold base gaskets.



PN479D

PN479D	1965-68 Carb to Manifold Hollow Vacuum Stud w/ Nut (RE).....	15.00/ea.
---------------	--	-----------

Note: This is the hollow stud used in securing the carb to the manifold as well as being a vacuum supply port. One per carb.



PN479E

PN479E	1955-66 Carb Studs, All V8 (Set of 4) (RE).....	11.00/ea.
3 sets required for tri-power applications.		
PN479L	1967-77 Quadrajets to Manifold Bolt Kit (RE)	4.50/kit



PN479L

TRI-POWER ACCELERATOR LINKAGE

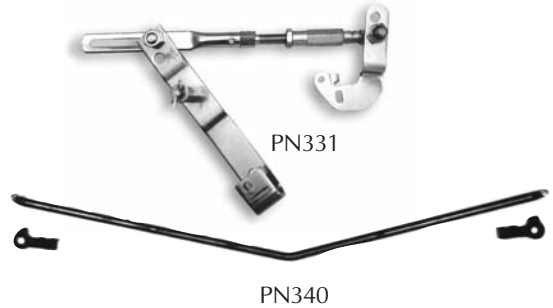

PN331

PN340

These linkage kits include necessary hardware to convert to or replace driver's side mechanical linkage on your Tri-Power.

All 1959-66 linkage kits now include PN341A (rear accelerator pump rod) which is necessary because original rods will interfere with linkage operation.

Comments: Very good.

PN329	1957-58 Tri-Power Mechanical Linkage (RE).....	\$59.00/ea.
PN329A	1959-60 Tri-Power Mechanical Linkage (RE).....	57.00/kit
PN330	1961-63 Tri-Power Mechanical Linkage (RE).....	57.00/kit
PN331	1964-65 Tri-Power Mechanical Linkage (RE).....	54.00/kit
PN332	1966 Tri-Power Mechanical Linkage (RE).....	54.00/kit
PN335C	1960-66 Tri-Power Center Carb Throttle Shaft Bracket (RE)	26.00/ea.

PN335C bolts directly to the throttle shaft and has the threaded screw hole in it (screw is not included). The PN329A-PN332 accelerator linkage lever bolts to this. Gold-Cad plated.

PN340	1959-66 Tri-Power Carburetor Linkage w/Clips—Passenger Side (Connects front and rear carburetors) (RE).....	7.50/set
PN340B	1964-66 Tri-Power Rear Carb Lever, Drivers Side	7.50/ea.

TRI-POWER SPRINGS, PUMP RODS AND LEVERS



PN340K

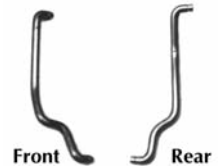

Front

Rear

PN341B

PN340J	1959-66 Tri-Power Secondary Rod Springs (RE) .	4.00/pr.
PN340K	1959-66 Tri-Power Secondary Rod Springs - Heavy Duty (RE)	5.50/pr.
PN341	1959-66 Tri-Power Accelerator Pump Rod (Front Carb) (RE).....	8.00/ea.
PN341A	1959-66 Tri-Power Accelerator Pump Rod (Rear Carb) (RE).....	8.00/ea.
PN341B	1959-66 Tri-Power Accelerator Pump Rod Set (Front & Rear Carbs) (RE)	16.00/set
PN341DA	1959-65 Tri-Power Accelerator Pump Rod (Center Carb) (RE)	8.00/ea.
PN341DC	1966 Tri-Power Accelerator Pump Rod (Center Carb) (RE)	8.00/ea.



PN341DD



PN341DG

PN341DD	1959-66 Tri-Power Lower Accelerator Pump Rod (Front Carb) (RE).....	8.00/ea.
PN341DG	1959-66 Tri-Power Accelerator Pump Rod Shaft (Front or Rear) (RE).....	16.00/ea.



- | | | | |
|----------------|--|-------|-------------|
| | PN341F | PN342 | |
| PN341DH | 1964-66 Tri-Power Accelerator Pump Rod Shaft (Front or Rear) (RE)..... | | \$22.00/ea. |
| PN341F | 1959-66 Tri-Power Accelerator Pump Lever, End Carbs Only (Frt or Rear) (RE)..... | | 7.50/ea. |
| PN342 | 1961-63 Tri-Power Vacuum Control Rod and Clip (RE)..... | | 11.00/ea. |

PN342 is the rod and clip that connect the front carburetor to the vacuum pot.

THROTTLE SHAFTS & COMPONENTS



- | | | | |
|----------------|---|--|-----------|
| | PN343KK | | |
| PN343KK | 1960-65 Tri-Power Throttle Shaft - Center Carb (RE) | | 42.00/ea. |
| PN343KM | 1966 Tri-Power Throttle Shaft - Center Carb (RE) | | 42.00/ea. |
| PN343KP | 1959-66 Tri-Power Throttle Shaft - End Carbs (RE) | | 42.00/ea. |

All throttle shafts come with necessary screws and are of the highest quality.



- | | | | |
|----------------|--|---------|-----------|
| | PN343KS | PN343LC | |
| PN343KS | 1967-70 Quadrajete Throttle Shaft & Bracket (RP) | | 64.00/ea. |
| | N186KS will replace a worn original shaft or allow the use of an Olds, Buick or Cadillac Quadrajete carburetor on a Pontiac. | | |
| PN343LC | 1964-65 Tri-Power Center Carb Throttle Plates (RE) | | 25.00/pr. |
| PN343LE | 1964-65 Tri-Power End Carb Throttle Plates (RE) | | 27.00/pr. |

THROTTLE SHAFT LEVERS



- | | | | |
|----------------|--|-------|-----------|
| | PN325 | PN328 | |
| PN325 | 1959-66 Tri-Power Carburetor Linkage Lever, RH Front (RE)..... | | 6.50/ea. |
| | This linkage lever is used on the passenger side of all '59-'66 front carburetors. It has the necessary slotted hole for the passenger side linkage. | | |
| PN324A | 1957-63 Tri-Power Carburetor Linkage Lever, Rh Rear (RE)..... | | 6.50/ea. |
| PN325A | 1964-66 Tri-Power Carburetor Linkage Lever, RH Rear (RE)..... | | 6.50/ea. |
| PN325AD | 1964-66 Tri-Power Carburetor Linkage Lever, RH Front (RE)..... | | 6.50/ea. |
| PN328 | 1969-72 Quadrajete Throttle Shaft Lever - GP w/Idle Solenoid (RE) | | 17.00/ea. |
| PN328B | 1969-72 Quadrajete Throttle Shaft Lever - GP w/o Idle Solenoid (RE)..... | | 17.00/ea. |

CHOKE COMPONENTS



- | | | | | |
|---------------|---|-------|--------|-------------|
| | PN228 | PN229 | PN230B | |
| PN228 | 1966 Tri-Power Choke Thermostat Housing, Coil and Rod (AP)..... | | | \$37.00/ea. |
| PN229 | 1967 4 bbl Choke Thermostat Housing, Coil and Rod (AP)..... | | | 37.00/ea. |
| PN230 | 1968-70 4 bbl Choke Thermostat Housing, Coil, and Rod (AP)..... | | | 37.00/ea. |
| | These units bolt to the intake manifold and include the control rod and correct clip. | | | |
| PN230B | 1966-70 Choke Thermostat Housing Bolt and Washer, SS (RE) | | | 2.50/ea. |



- | | | | |
|---------------|--|-------|-----------|
| | PN231 | PN232 | |
| PN231 | 1957-67 Carter AFB Choke Cover & Coil (NOS) | | 41.00/ea. |
| PN231B | 1957-67 Carter AFB Choke Cover & Coil No Script (RE) | | 24.00/ea. |
| PN232 | 1959-65 Tri-Power Choke Cover & Coil (RM) ... | | 36.00/ea. |



- | | | | |
|----------------|--|--------|-----------|
| | PN210 | PN211A | |
| PN210 | Tri-Power Thermostatic Vacuum Block-Off Plate (RE)..... | | 10.00/ea. |
| | This plate is used when vacuum-operated tri-power setups are converted to progressive linkage. The plate replaces the thermostatic vacuum control assembly mounted on the front of the intake. | | |
| PN211A | 1966 Tri-Power Choke Pull-Off Assembly (White like original) (RE)..... | | 17.00/ea. |
| PN211B | 1966 Tri-Power Choke Pull-Off w/o Bracket (White like original) (RE) ... | | Disc. |
| PN211C | 1966 Tri-Power ChokeQA Pull-Off Bracket Only (RE)..... | | 11.00/ea. |
| PN211AR | 1966 3X2 Choke Pull-Off Rod W/Clip (RE) ... | | 5.00/ea. |



- | | | | |
|---------------|---|--------|-----------|
| | PN211D | PN211G | |
| PN211D | 1967-69 Quadrajete Choke Pull-Off (RE)..... | | 19.00/ea. |
| PN211G | 1966 Tri-Power Center Carb Choke Lever (RE) | | 8.00/ea. |

THROTTLE CABLE BRACKETS



- | | | | |
|--------------|--|--|-----------|
| | PN305 | | |
| PN305 | 1969-71 4 bbl Throttle Cable Bracket - GP (RE) .. | | 44.00/ea. |
| PN306 | 1972-74 4 bbl Throttle Cable Bracket - All (RE) .. | | 20.00/ea. |

THROTTLE CABLE & SPRINGS



- PN311** 1969-71 Throttle Control Cable -GP (4 bbl) (GM) \$50.00/ea.
PN316C 1964-71 Accelerator Cable Cotter Pin (RP)50/ea.



PN216

- PN216** 1961-72 Yellow Throttle Return Spring
 -All (RE) 4.50/ea.

Note: We have seen both the yellow and blue springs used on original tri-power and 4bbl. cars.

- PN218** 1961-72 Blue Throttle Return Spring
 -All (RE) 4.50/ea.

This is a reproduction of the original blue return spring found on 1961-72 4 bbl as well as some 1961-66 tri-power cars.

Paint quality on PN216 & PN218 is fair.

- PN219** Dual Throttle Return Spring (AP) 6.00/ea.
 This is an aftermarket return spring. Not used originally by Pontiac.



PN219

TRI-POWER CHOKE LINES



PN291

- PN290** 1961-63 Complete Choke Line Kit
 w/Manifold Plate and Manifold
 Lines (RE) 48.00/kit
PN291 1964 Complete Choke Line Kit
 w/Manifold Plate and Manifold
 Lines (RE) 48.00/kit

Note: These kits are to be used where the manifold plate and tubes are missing completely or where the manifold tubes have rusted and broken from the plate.

- PN292** 1961-64 Manifold Plate Gasket (RE) 3.50/ea.
PN292A 1961-64 Manifold Plate w/Gasket (RE) 32.00/ea.

Note: This is the plate that mounts to the manifold where the choke lines insert for hot air.

- PN292B** 1957-58 Choke Line (RE) 10.00/ea.
PN292C 1959-60 Choke Line (RE) 10.00/ea.
PN292F 1955-60 Inner Choke Line (RE) 29.00/ea.

Note: This inner tube presses into the intake manifold.

- PN294** 1961-63 Choke Lines w/o Spacers
 Under Carbs (RE) 19.00/set
PN294A 1961-63 Choke Lines w/Spacers
 Under Carbs (RE) 19.00/set
PN295 1964 Choke Lines (RE) 19.00/set

Note: PN294 through PN295 are to be used only if the manifold tubes are in good shape and attached firmly to the plate. If the manifold tubes fall off, unfiltered air and rust particles may be drawn into the carburetor.

- PN296** 1965 Choke Lines (RE) 19.00/set
Comments: Very good.

2 & 4 BBL CHOKE LINES



PN299A

- PN299** 1961-64 4 bbl Choke Lines (RE) \$19.00/set
PN292A 1961-64 Manifold Plate w/ Gasket 4 bbl (RE) 32.00/ea.
PN299A 1965-66 4 bbl Choke Lines (RE) 19.00/set
PN299D 1965-67 2 bbl Choke Lines (RE) 19.00/set

CHOKE TUBE



PN300

- PN300** 1965-67 Manifold Choke Tube (RE) 26.00/ea.
Applications: 1965 All V8, 1966 2 & 4 bbl V8 and 1967 2 bbl V8.

This tube is inside the manifold and the choke lines push into it. To install, push tube in from the inside and take a center punch inside the tube to flare outwhile securing from the bottom.

CARBURETOR FITTINGS



PN232DA

PN232DC

PN232DE

- PN232DA** 1957-58 Tri-Power Center Carburetor Vacuum
 Fitting Plug (RE) 18.00/ea.
PN232DC 1959-64 Tri-Power Center Carburetor Vacuum
 Fitting Plug 5/16" - 24 (RE) 18.00/ea.
PN232DE 1964-65 Tri-Power Center Carburetor Vacuum
 Fitting Plug 3/8" - 24 (RE) 18.00/ea.

Use PN232DA - PN232DE to block off AC vacuum tees (PN232J-
 PN232P) for non AC applications.

Note: 1964 used two different sizes. Please check size before ordering.



PN232FC



PN344KR

- PN232FC** 1959-66 Tri Power Vacuum Actuator (RE) 55.00/ea.

PN232FC is the accelerator linkage vacuum actuator. It is not used with mechanical (progressive) style linkage. Fits all 59-64 tri power and 65-66 tri power with automatic transmissions.

- PN344KR** 1959-65 Tri-Power Front Carb Vacuum Bleed-off
 Tube (RE) 8.00/ea.

**SAVE TIME
 ORDER ONLINE
 24
 Hours
 A
 Day**

www.amesperf.com



- | | | | |
|--|---|--------|-------------|
| | PN232M | PN234Y | |
| PN232J | 1957-58 Tri-Power Center Carburetor Vacuum Fitting (RE) | | \$33.00/ea. |
| PN234Y | 1957-58 Tri-Power Front Carburetor Power Brake 90° Vacuum Fitting (RE) | | 34.00/ea. |
| This is the correct brass fitting for the vacuum line. | | | |
| PN232K | 1959-62 Tri-Power Center Carburetor Vacuum Fitting, All w/ AC (RE) | | 33.00/ea. |
| <i>Note: PN232K also fits 1959 2BBL and 4BBL without power brakes.</i> | | | |
| PN232M | 1964 Tri Power Center Carburetor Vacuum Tee with 1/8" AC Supply Fitting, All w/ AC (RE) | | 33.00/ea. |
| PN232P | 1964-65 Tri Power Center Carburetor Vacuum Tee with 3/16" AC Supply Fitting, All w/ AC (RE) | | 36.00/ea. |

PN232K - PN232P supply vacuum to both the distributor vacuum advance and the AC diaphragm. Two different size AC fittings were used for 1964. Please be sure to measure original before ordering. In conjunction with the tee, PN211J vacuum advance fitting is needed.

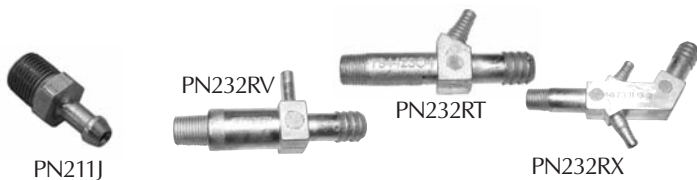

- | | | |
|----------------|---|-----------|
| PN211J | 1964-66 Center Carb Vacuum Advance Fitting (RE) | 3.50/ea. |
| PN232RR | 1968-74 Carb Vacuum Line Fitting, w/o PB (RE) | 3.50/ea. |
| PN232RV | 1968 Carb Vacuum Line Fitting, w/PB (RE)..... | 19.00/ea. |
| PN232RT | 1969-74 Carb Vacuum Line Fitting, w/PB (RE)... | 19.00/ea. |
| PN232RX | 1972-74 Carb Vacuum Line Fitting, w/PB (RE)... | 27.00/ea. |

These fittings screw into the rear of the carburetor base plate. All applications are not yet determined on N139PT through N139PX. Please refer to photos for your application.

VACUUM LINE COMPONENTS



- | | | |
|--------------|--|-----------|
| | PN235 | |
| PN235 | 1961-66 Tri-Power Brake Vacuum Line w/Fitting (RE) | 26.00/ea. |

This steel line connects the front carb vacuum port to the power brake vacuum hose.

Note: This correct line and fitting is excellent.

- | | | |
|----------------|---|-----------|
| PN235A | 1960-66 Tri-Power Brake Vacuum Line Fitting (RE) | 16.00/ea. |
| PN235AB | 1957-66 Tri-Power Brake Vacuum Line Fitting Plug (RE) | 18.00/ea. |

Use PN235AB in conjunction with PN234Y (1957-59) or PN235A (1960-66) for all non power brake applications. This is how GM blocked off the vacuum port at the rear of the front carb.

- | | | |
|---|---|----------|
| PN235AD | 1964-65 4-Barrel Power Brake Line (RE)..... | 7.50/ea. |
| This line connects the carburetor to the power brake vacuum hose. | | |
| PN235J | Power Brake Vacuum Hose (RP)..... | 1.50/ft. |
| PN235JC | Power Brake Vacuum Hose Clamp (RP) | .75/ea. |



- | | | | |
|---------------|---|--------|------------|
| | PN238J | PN238L | |
| PN238J | 1961-66 Power Brake Vacuum Line Bracket (RE) | | \$6.50/ea. |
| PN238L | 1967 Power Brake Vacuum Line Bracket (RE) | | 6.50/ea. |



- | | | | |
|---------------|--|--------|-----------|
| | PN487R | PN488T | |
| PN487R | 1968-72 Intake Vacuum Supply Fitting (RE) | | 9.00/ea. |
| PN488P | 1967 Vacuum Advance Lines (Calif. Only) - AT (RE)..... | | 25.00/set |

This is a steel two-piece set.

- | | | |
|---------------|--|-----------|
| PN488R | 1967 Vacuum Advance Line (Exc. Calif.) - MT (RE) | 13.00/ea. |
|---------------|--|-----------|

This is a steel one-piece line.

- | | | |
|---------------|---|-----------|
| PN488S | 1968 Vacuum Advance Line, All V8 (RE) | 15.00/ea. |
| PN488T | 1969 Vacuum Advance Line, 4 Bbl MT (RE).. | 13.00/ea. |

This steel line mounts on the driver's side of the carburetor routing ported vacuum to the distributor.

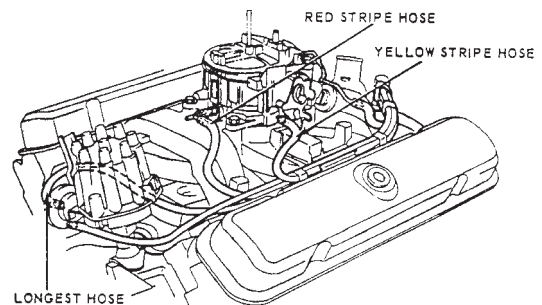

- | | | |
|---------------|--|-----------|
| PN489K | 1968 Vacuum Hose Kit w/ Thermostatic Switch Plug, 5 Port Design (RE) | 56.00/kit |
| PN489N | 1969 Vacuum Hose Kit w/ Thermostatic Switch Plug, 3 Port Design (RE)..... | 41.00/kit |

These kits contain the rubber plug with color-coded vacuum hoses that connect the switch to all the components, instructions included. The vacuum switch is not included or available.

Since new federal laws mandate 1968 and newer cars be equipped with original pollution control devices, these kits are a must.

- | | | |
|--|---|---------|
| PN487P | 1968-69 Thermostatic Vacuum Control Switch (RP) | Inquire |
| This switch mounts on the front of the intake manifold. It is imperative for the correct operation of your car that this unit function properly. | | |
| <i>Note: Applications for this part are as follows: 1968 All and 1969 All AT.</i> | | |

- | | | |
|---|--|-----------|
| PN488C | 1975-77 Thermostatic Vacuum Control Switch 4 Port (RP) | 58.00/ea. |
| PN488C mounts on the front passenger side of the intake manifold. | | |
| PN488F | 1975-77 Thermostatic Vacuum Control Switch 2 Port (RP) | 26.00/ea. |

PN488F mounts on the #2 Intake runner

- | | | |
|---------------|--|-----------|
| PN488J | 1975-77 Thermostatic Vacuum Control Switch 2 Port (RP) | 43.00/ea. |
|---------------|--|-----------|

PN488J mounts on the air cleaner base.

- | | | |
|----------------|--|----------|
| PN489RC | 5/32" White Striped Vacuum Hose, Per Foot (RE) | 2.00/ft. |
|----------------|--|----------|

This hose was used by GM for various years and applications.

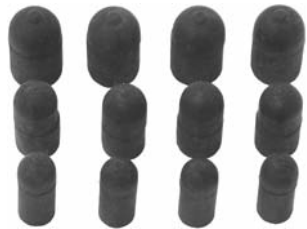

PN489RJ

PN489RJ Vacuum Port Plug Kit (AP)..... \$3.50/kit

This kit contains 1/4", 1/8", and 3/16" plugs for various locations where the port is not used.

DASH POTS AND IDLE STOP SOLENOIDS



PN455J

PN455N

PN455T

PN455J 1960-67 Dash Pot All Carter AFB (AP) Disc.

PN455N 1968-72 Idle Stop Solenoid (AP)..... Inquire

The original solenoids for these cars have been discontinued. Most replacements do not have the correct bracket.

Note: Correct applications for this piece include 1968 All, 1971 All 4 B.C.-MT and 1972 All 4 B.C.

PN455T 1968-70 Idle Stop Solenoid Bracket (RE)..... 16.00/ea.

Note: PN455T will work on 1971-72 cars with some modifications needed.

PCV COMPONENTS

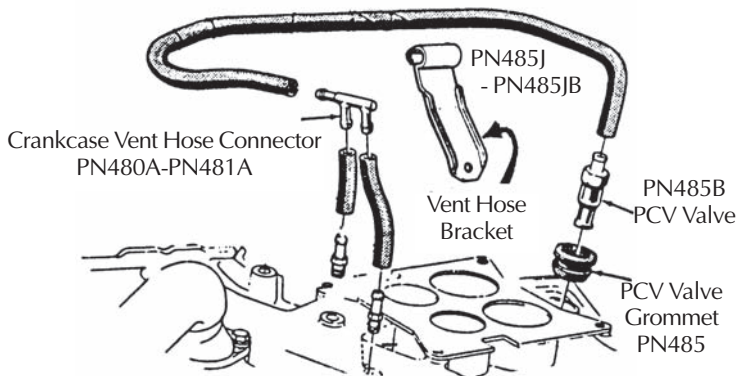

PN480A

PN481A

PN480A 1963-65 4-Barrel and 1964-65 Tri-Power Crankcase Vent Hose Connector Steel (RE) 16.00/ea.

PN481A 1966 Tri-Power Crankcase Vent Hose Connector Steel (RE)..... 16.00/ea.

This plated steel connector is an excellent alternative to the more common nylon connectors (no longer available), some had steel.

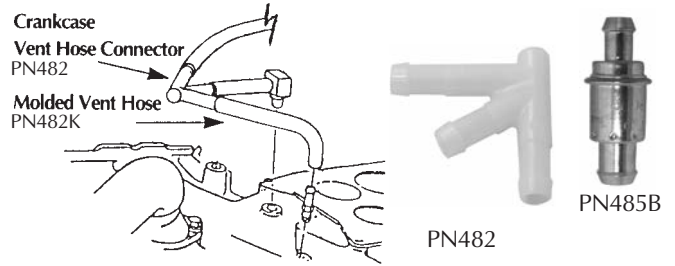

PN482 1966 4-Barrel and All 1967 V8 Crankcase Vent Hose Connector Nylon (RE) \$18.00/ea.

PN482K 1966-67 V8 Crankcase Molded Vent Hose, 2 & 4 BBL (APE) 9.00/ea.

This small molded hose is a fine detail item. Using standard straight hose results in a large incorrect loop.

PN485 1957-77 PCV Valve Grommet (GM) 3.50/ea.

This grommet fits in the back of the valley cover and houses the PCV valve.

PN485B 1957-77 PCV Valve (GM)..... 7.00/ea.



PN485D PCV Hose 3/8" (AP) 1.50/ft.

PN485DC PCV Hose 3/8" w/ Correct "GAS GAS" Print (RE)..... 4.00/ft.

There has been much controversy whether this was used by the factory for PCV hose. We have researched factory photos and low-mileage original cars and found this "GAS GAS" printed hose for the PCV system.



PN485E PCV Hose Clamps (RE)..... .75/ea.

PN485J 1957-64 Crankcase Vent Hose Bracket (RE) 18.00/ea.

PN485JB 1965-Early '66 Crankcase Vent Hose Bracket (RE) 21.00/ea.

PN485B 1957-77 PCV Valve (GM)..... 7.00/ea.

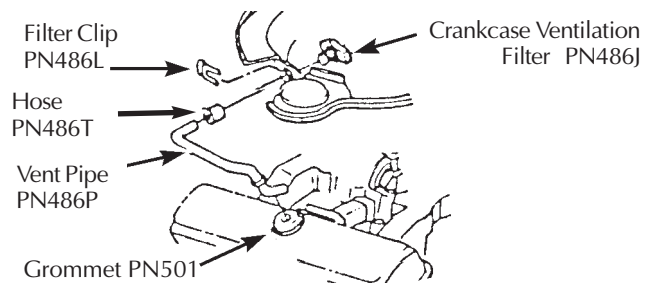

PN485JD Late '66-67 Crankcase Vent Hose Bracket (RE) 16.50/ea.

These vent hose brackets are rolled like original. See diagram above PN480A for vent hose brackets.

PN486J 1968-77 Crankcase Ventilation Filter (AP)..... 5.50/ea. PN486J mounts inside the air cleaner and connects to the crankcase vent pipe.

Note: Does not include PN486L Clip.

PN486L 1968-77 Crankcase Ventilation Filter Clip (RP) ... 2.50/ea.

This clip holds PN486J in place.

PN486N 1965 Crankcase Vent Pipe, 421 HO w/Closed Crankcase (RE)..... 47.00/ea.

PN486P 1968-73 Crankcase Vent Pipe (RE)..... 30.00/ea.

PN486T Vent Pipe to Filter Hose w/ Correct Ribbed Design (RE) 2.00/ea.

INTAKE MANIFOLDS & COMPONENTS



PN284FG

PN284FG 1966 Aluminum Tri-Power Intake Manifold (RE)..... \$399.00/ea.

PN284FG will fit all 1965-71 Pontiac V8's. They are cast just like the originals but in aluminum with the correct 1966 casting #9782898.



PN284HA

PN284HA 1965-73 Edelbrock "Performer" Intake Manifold, All non-EGR Pontiac 326-455cid (AP) ... 269.00/ea.

Operating range for PN284HA is idle - 5000 RPM

Note: PN284HA will accept OEM style Quadrajet carburetors.

PN284HB 1965-77 Edelbrock "Performer RPM" Intake Manifold, All non-EGR Pontiac 326-455cid (AP) . 285.00/ea.

Operating range for PN284HB is 1500 - 5000 RPM

Note 1: PN284HB will accept OEM style Quadrajet carburetors as well as non-spread-bore style.

PN284HC 1965-77 Edelbrock Torker-II Intake Manifold, All non-EGR Pontiac 389-455cid (AP) ... 298.00/ea.

Operating range for PN284HC is 2500 - 6500 RPM

Note 1: PN284HC will not accept OEM style carburetors without the use of an adapter plate - see PN284HF.

Combine an Edelbrock Intake with other Edelbrock components offered in this section for the Edelbrock "Total Power Package" no guess-work performance.

PN284HF Edelbrock OEM Carb Adapter Plate (AP) 45.00/ea.

PN284HF is required when using your OEM carburetor on the PN284HC non-spread-bore intake.

No further discounts apply to intake manifolds.



PN285JB

PN285JB 1965-77 Intake Manifold Bolt Kit - All Pontiac V8 Exc. RA IV & 455HO (AP) 12.00/kit

These bolts do not have the same head markings as originals. Kit does not come with stud bolts for AC or alternator brackets for later years.



PN285P

- PN285N** 1957-60 Intake Manifold Gasket Set
-All Pontiac V8 (RP)..... \$19.00/set
- PN285P** 1961-64 Intake Manifold Gasket Set
-All Pontiac V8 (RP)..... 17.00/set
- PN285R** 1965-71 Intake Manifold Gasket Set- All Pontiac V8
Exc. RA IV & 1971 455HO (RP)..... 23.00/set
- PN285T** 1969-71 Intake Manifold Gasket Set
-All RA IV & 1971 455HO (RP)..... 23.00/set
- PN285V** 1972-77 Intake Manifold Gasket Set- All Pontiac V8
Exc. 301, 455HO & 455SD(RP)..... 19.00/set
- PN285VP** 1965-77 Intake Manifold Gasket Set
w/Crossover Blockoff (RP) 18.00/set

Note 1: The exhaust crossover (center) ports on PN285VP are blocked to minimize heat distribution to the carburetor thus making the choke inoperable. Recommended for high performance applications.

Note 2: PN285VP does not include the o-ring or plastic guide retainers.

INTAKE VALLEY PANS & GASKETS

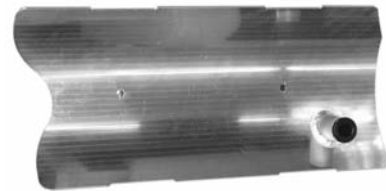

PN285W

PN285W 1968-77 Aluminum Intake Valley Pan w/Gasket (AP)..... 89.00/ea.

Comments: PN285W is an aftermarket performance valley pan made of 1/8" aluminum. PN285W will not fit with EGR valve equipped intake manifolds. Some alterations to PN285W may be needed for a perfect fit. Please inquire for more details.



PN285WF

PN285WF 1968-72 OEM Style Valley Pan (AP) 149.00/ea.

PN285WF is zinc plated.

PN285WG 1968-72 OEM Style Valley Pan (AP) 149.00/ea.

PN285WG is gold cad.



PN286A

- PN286A** 1961-64 Valley Pan Gasket (RP)..... 8.00/set
- PN286B** 1965-67 Valley Pan Gasket (RP)..... 8.00/set
- PN286C** 1968-77 Valley Pan Gasket (RP)..... 8.00/set

ENGINE ACCESSORY BRACKETS & COMPONENTS



- PN269K** 1964 Rear Alternator Strap, All w/PS
Exc. Tri-Power (RE) \$20.00/ea.
- PN269L** 1964 Front Alternator Strap, All V8 w/ PS (RE) 20.00/ea.



- PN270** 1965-66 Tri-Power Rear Alternator Strap w/PS (RE) 31.00/ea.
This is an auxiliary strap that attaches to the driver's side water neck bolt and connects with the water pump to alternator strap. It is used in conjunction with PN270AA.



- PN270D** 1965-66 Rear Alternator Strap, All V8 w/PS exc. Tri-Power (RE)..... 20.00/ea.
This strap mounts to the front thermostat housing bolt.
- PN270AA** 1965-66 Front Alternator Strap, All V8 w/PS (RE). 20.00/ea.
This strap bolts to the top water pump bolt.
- PN270A** 1965-67 Front Alternator Strap, All V8w/o PS (RE) 20.00/ea.
This strap bolts to the upper left-hand water pump bolt.
- PN270E** 1967-69 Rear Alternator Strap, All V8 w/PS (RE). 20.00/ea.
This strap mounts to the front thermostat housing bolt.



- PN270B** 1967-68 Front Alternator Strap, All V8 w/PS (RE) 20.00/ea.
This strap bolts to the top water pump bolt.
- PN270C** 1969 Front Alternator Strap, All V8 w/PS (RE) 20.00/ea.
This strap bolts to the top driver's side water pump bolt.

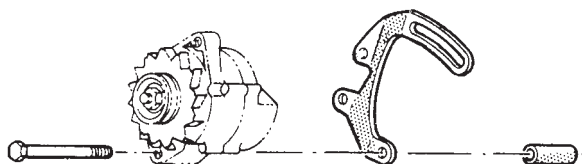

- PN270J** 1969-70 Alternator Bracket w/Bolts and Sleeve w/o PS (RE)..... 41.00/ea.



- PN270L** 1967-70 Alternator Pivot Bracket, All V8 w/PS (RE) \$15.00/ea.
- PN270N** 1964-70 Air Conditioning Compressor Rear Mounting Bracket, All V8 exc. 1965 (RE) 19.00/ea.
- PN270RC** 1966-70 Air Conditioning Compressor Bracket Bolt/Spacer Kit (RE) 74.00/ea.
- PN270NE** 1965-66 Power Steering Pump Mounting Bracket (RE) 39.00/ea.
- PN270NF** 1965-66 Power Steering Pump Mounting Plate (RE) 32.00/ea.



- PN270P** 1967-70 Power Steering Mounting Bracket, All V8 (RE) 29.00/ea.
- PN270PF** 1966-70 "Correct" PS Pump & Alternator Mounting Hardware Kit (RE)..... 39.00/ea.
- PN270PG** 1964-77 Power Steering Pump Mounting Stud (RE) 5.00/ea.

TRI-POWER THERMOSTAT HOUSINGS



- PN245** 1957 Tri-Power Thermostat Housing (RE)..... Disc.
- PN246** 1958 Tri-Power Thermostat Housing (RE)..... 47.00/ea.



- PN247** 1959 Tri-Power Thermostat Housing (RE)..... 47.00/ea.
- PN248** 1960 Tri-Power Thermostat Housing (RE)..... Disc.

- PN249** 1961-63 Tri-Power Thermostat Housing (RE)..... 47.00/ea.
Note: This is an exact reproduction of the 1961 to 1963 aluminum water neck. They are cast with the correct casting numbers.
- PN250** 1964 Tri-Power Thermostat Housing (RE)..... 47.00/ea.
- PN251** 1965-66 Tri-Power Thermostat Housing (RE)..... 36.00/ea.

Note: PN245 through PN248 are done in cast iron and have original shape and design.

Note: PN250 and PN251 are done in cast iron and have original shape with all casting numbers.

Comments: All our Tri-Power thermostat housings are very good to excellent.

2 BBL & 4 BBL THERMOSTAT HOUSINGS AND THERMOSTATS



	PN254		
PN253	1958-60	Thermostat Housing, 2 bbl & 4 bbl (AP)	\$19.00/ea.
PN254	1965-70	Cast Aluminum Thermostat Housing, 2 bbl & 4 bbl (RE).....	26.00/ea.
PN255	1965-70	Thermostat Housing, 2 bbl & 4 bbl (AP).....	22.00/ea.
PN256	1971-77	Cast Iron Thermostat Housing, 2 bbl & 4 bbl (AP).....	19.00/ea.



	PN256AM	PN256AP	PN256AR	
PN256AJ	1964-77	HD Thermostat w/Gasket, 180° All Pontiac V8 (AP)		14.00/ea.
PN256AM	1955-77	Thermostat w/ Gasket, 180°, All Pontiac V8 exc. 301 (RP).....		6.50/ea.
PN256AN	1955-77	Thermostat w/ Gasket, 195°, All Pontiac V8 exc. 301 (RP).....		6.50/ea.
PN256AP	1955-77	Thermostat Housing Gasket (RP)		2.50/ea.
PN256AR	1963-72	Thermostat Housing Bolt w/Washer, All Pontiac (GM).....		5.00/ea.

This is the hard-to-find bolt with the alternator bracket stud.

REMANUFACTURED WATER PUMPS



	PN256F	PN256J	
PN256B	1955-63	4 Bolt Water Pump w/ Gasket, All Pontiac V8 (RP)	42.00/ea.
PN256C	1963-68	Water Pump w/ Gasket, All Pontiac V8 w/ 8 Mounting Bolts (RP).....	37.00/ea.
PN256F	Early 1969	Water Pump w/ Gasket, All Pontiac V8 (RP)	36.00/ea.

This is the hard-to-find short 4" hub used on early production '69 cars. This measurement is taken from the face of the hub to the surface that mounts to the timing cover.

PN256J	1969-77	Water Pump w/ Gasket, All Pontiac V8 exc. 301 (RP).....	32.00/ea.
---------------	---------	---	-----------

Note: PN256B - PN256J are remanufactured water pumps that carry a 90-day warranty.

NEW WATER PUMPS



PN257A	1955-63	New Water Pump w/ Gasket, All Pontiac V8 w/ 4 Mounting Bolts (RP)	\$82.00/ea.
PN257B	1963-68	New Water Pump w/ Gasket, All Pontiac V8 w/ 8 Mounting Bolts (RP)	82.00/ea.
PN257E	Early 1969	New Water Pump w/ Gasket, All Pontiac V8 (RP)	88.00/ea.
		Please refer to PN256F for identifying this pump.	
PN257H	1969-77	New Water Pump w/ Gasket, All Pontiac V8 exc. 301 (RP).....	51.00/ea.

Note: PN257B - PN257H are new water pumps. These carry a 1-year warranty.

ALUMINUM WATER PUMP

PN257J	1969-77	Aluminum Water Pump With Gasket (AP)	120.00/ea.
---------------	---------	--	------------

This water pump has 11 mounting bolts and the 4 1/2" hub measurement.

FLOWCOOLER® WATER PUMPS



PN257HC

Flow-Cooler water pumps are the highest flow-rate mechanical pumps on the market today for engine speeds between idle and 3000 RPM. Testing has shown increases of 100% more GPM at idle and 20% more at 2000RPM. Flow-Cooler pumps also increase water pressure by 22%, suppressing engine hot-spots, steam-pockets, and pinging. These pumps are new. Gasket included.

PN257HC	1963-68	Flow Cooler® Water Pump w/Gasket (AP)	119.00/ea.
PN257HD	1969-77	Flow Cooler® Water Pump w/Gasket (AP)	89.00/ea.
PN257HL	1969-77	Aluminum Flow Cooler® Water Pump w/Gasket (AP).....	129.00/ea.

PN257HD & PN257HL have the late 69 style 4-1/2" hub.

WATER PUMP GASKETS, DIVIDER PLATES & BOLT KITS



PN258PA

PN258NT	1961-63	Water Pump Gasket, 4 Bolt (RP).....	4.50/ea.
PN258PA	1963-68	Water Pump Gasket, All Pontiac V8 (RP) ..	3.50/ea.
PN258PD	1969-77	Water Pump Gasket, 2 Required, All Pontiac V8 (RP)	3.50/ea.

Water pump components continue on next page.

Water Pump components continued.



PN258PF

PN258PF 1963-68 Water Pump Divider Plates - Stainless Steel (APE) \$49.00/set

Note: Using stainless steel, we are now able to supply the ultimate in rust-resistant divider plates.

Note: Since these plates are used in many different housings, slight contouring may be necessary in your application.

PN258PJ 1969-77 Water Pump Divider Plate, Steel (GM)... 9.00/ea



PN258PK

PN258PK 1969-77 Water Pump Divider Plate, Stainless Steel (RE) 29.00/ea.

PN258PT 1969-77 Water Pump Sleeves w/ Seal (GM)..... 17.00/pr.

PN258PTS 1969-77 Water Pump Sleeves, Stainless Steel w/ Seal, Pair (RE) 29.00/pr.



PN259BS

PN259A 1964-68 "Correct" Water Pump Bolt (RE)..... 3.00/ea.

PN259B 1969-77 "Correct" Water Pump Bolt w/ Slotted Head, Each (RE) 3.00/ea.

PN259AH 1964-68 "Correct" Water Pump Bolt Kit w/ Slotted Head, 8 pc. (RE) 35.00/ea.

PN259BS 1969-77 "Correct" Water Pump Bolt Kit w/Slotted Head, 11 pcs. (RE)..... 30.00/kit

TIMING CHAIN COVER & COMPONENTS



PN638

PN638 1969-77 Timing Chain Cover - All Pontiac V8 exc. 301 (APE) 179.00/ea.

These high-pressure aluminum die-castings exhibit extremely close tolerances using the latest in machine tool technology.

This eleven-bolt water pump design cover can also be used as a replacement for 1961-68 non-tri-power engines by also replacing other components such as pulleys water pump, mounting brackets, etc. Call for more details.

Note: Beware of low-quality sand-cast reproductions of this part.



PN638AC

PN638AC 1969-77 Timing Chain Cover Alignment Sleeves - All Pontiac V8 exc. 301 (APE)..... \$7.00/pr.



PN638J

PN638C 1959-62 Timing Chain Cover Gasket Set - All Pontiac V8 (RP) 21.00/set

PN638F 1963 Timing Chain Cover Gasket Set - All Pontiac V8 w/ 4 Bolt Water Pump (RP) 32.00/set

PN638G 1963-77 Timing Cover to Balancer Seal (AP)..... 16.00/ea.

PN638J 1963-77 Timing Chain Cover Gasket Set -All Pontiac V8 , exc. 4 Bolt Water Pump (RP) 25.00/set



PN638L

PN638L 1959-77 Timing Cover to Intake Seal (RE) 2.00/ea.



PN639

PN639 1959-77 Timing Chain Cover Bolt Kit, All Pontiac V8 (RP)..... 10.00/kit

PN640 1959-77 Timing Chain Cover Stud - All Pontiac V8 (RP) 2.50/ea.

Measures 3/8" x 3 11/16" 2 required per car.



PN642

PN642 1962-77 Intake Manifold to Timing Chain Cover Bolt and Clamp (RE) 9.00/ea.



PN641

PN641 1962-77 Engine Hoist Bracket (RE) 7.50/ea.

Mounted on the upper right hand timing chain cover bolt. This bracket was originally used when lowering the engine into the chassis.

ENGINE PULLEYS



These are aluminum billet pulleys that exhibit the same contours and appearance as originals. They are available in black powder-coated or polished aluminum with a ceramic hybrid coating. Pulleys are manufactured at 6000 rpm assuring true performance with deep grooves to prevent belt-tossing. With a black pulley set, the alternator pulley will be gold anodized.

Note: 3-piece pulley sets include the crank pulley, water pump pulley and alternator pulley. In addition to this, 4-piece pulley sets will include the power steering pump pulley. A/C Compressor Pulleys are not included in any pulley set.

Quality: Very good to excellent.

BLACK PULLEYS

PN850	1964	Black Pulley Set w/AC, w/Power Steering & 2 Belt System - 4 pieces (AP).....	\$409.00/set
PN850C	1965-67	Black Pulley Set with Standard Steering & w/o AC - 3 Piece (AP).....	309.00/set
PN850E	1965-67	Black Pulley Set with Power Steering & w/o AC - 4 Piece (AP).....	349.00/set
PN850G	1965-67	Black Pulley Set with Power Steering & w/AC - 4 Piece (AP)	349.00/set
PN850I	1968	Black Pulley Set with Standard Steering & w/o AC - 3 Piece (AP).....	309.00/set
PN850J	1968	Black Pulley Set with Power Steering & w/AC - 4 Piece (AP)	359.00/set
PN850L	1968	Black Pulley Set with Power Steering & w/o AC - 4 Piece (AP).....	349.00/set
PN850N	Early 1969	Black Pulley Set with Power Steering & w/o AC - 4 Piece (AP).....	349.00/set
PN850P	Early 1969	Black Pulley Set with Power Steering & w/AC - 4 Piece (AP)	349.00/set
Note: PN850N & PN850P fit applications with the early style 4" (short hub), 11-bolt water pump.			
PN850R	Late 1969-70	Black Pulley Set with Standard Steering & w/o AC - 3 Piece (AP).....	349.00/set
PN850T	Late 1969-70	Black Pulley Set with Power Steering & w/o AC - 4 Piece (AP).....	349.00/set
PN850V	Late 1969-70	Black Pulley Set with Power Steering & w/AC - 4 Piece (AP)	349.00/set
PN850X	1971-74	Black Pulley Set with Power Steering & w/o AC - 4 Piece (AP).....	349.00/set
PN851	1971-74	Black Pulley Set with Power Steering & w/AC - 4 Piece (AP)	349.00/set

POLISHED PULLEYS

PN860	1964	Polished Pulley Set w/AC,w/ Power Steering & 2 Belt System - 4 pieces (AP).....	\$399.00/set
PN860AA	1965-67	Polished Pulley Set with Standard Steering & w/o AC - 3 Piece (AP).....	319.00/set
PN860A	1965-67	Polished Pulley Set with Power Steering & w/o AC - 4 Piece (AP).....	349.00/set
PN860C	1965-67	Polished Pulley Set with Power Steering & w/AC - 4 Piece (AP)	349.00/set
PN860E	1968	Polished Pulley Set with Standard Steering & w/o AC - 3 Piece (AP).....	309.00/set
PN860G	1968	Polished Pulley Set with Power Steering & w/AC - 4 Piece (AP)	349.00/set
PN860J	1968	Polished Pulley Set with Power Steering & w/o AC - 4 Piece (AP).....	349.00/set
PN860L	Early 1969	Polished Pulley Set with Power Steering & w/o AC - 4 Piece (AP).....	349.00/set
PN860N	Early 1969	Polished Pulley Set with Power Steering & w/AC - 4 Piece (AP)	349.00/set
Note: PN860L & PN860N fits applications with the early style 4" (short hub), 11-bolt water pump.			
PN860P	Late 1969-70	Polished Pulley Set with Standard Steering & w/o AC - 3 Piece (AP).....	349.00/set
PN860R	Late 1969-70	Polished Pulley Set with Power Steering & w/o AC - 4 Piece (AP).....	349.00/set
PN860T	Late 1969-70	Polished Pulley Set with Power Steering & w/AC - 4 Piece (AP)	349.00/set
PN860V	1971-74	Polished Pulley Set with Power Steering & w/o AC - 4 Piece (AP).....	349.00/set
PN860X	1971-74	Polished Pulley Set with Power Steering & w/AC - 4 Piece (AP)	349.00/set

OEM-STYLE PULLEYS

PN881	Late 1969-70	Crankshaft Pulley - All w/o Power Steering or AC - Single Groove (RE)	\$69.00/ea.
PN881B	Late 1969-70	Water Pump Pulley - All w/o Power Steering or AC (RE).....	69.00/ea.
PN881D	1969-70	Water Pump Pulley - All w/ Power Steering w/o AC - Double Groove (RE)	69.00/ea.

ENGINE COMPONENTS

CORRECT ENGINE V-BELTS



These belts are embossed with "GM" logo, Pontiac part number, two-letter broadcast code and date code. Addition of these belts is not only a great complement to your engine compartment, but also a great way to step above the competition at the shows.

Due to GM's superceding part numbers some listings may not match the parts book for that model year.

Date Code Information: Before ordering please verify the vehicle build date from the cowl plate to ensure the proper date-code for your application. We offer two date-code options for each belt: 3rd quarter and 1st quarter. Belts were manufactured one to six months prior to the vehicle manufacture date. **Example 1:** A 1965 car built 08C (3rd week in August 1964) would require a 3rd quarter date code (3Q64). **Example 2:** A 1965 car built 04B (2nd week in April 1965) would require a 1st quarter date-code (1Q65).

When ordering, please add the appropriate date-code suffix to the correct part number for your application.

A=3rd Quarter

B=1st Quarter

Example 1: PN829A with the "A" suffix added will give you PN829AA, a 1964 alternator belt w/o PS, w/o AC, with a date-code 3Q63.

Example 2: PN829A with the "B" suffix added will give you PN829AB a 1964 alternator belt w/o PS, w/o AC, with a 1Q64 date code.

1964 All V8 Without Power Steering, Without AC		
PN829A	Alternator Belt (RE).....	\$38.00/ea.
1964 All V8 Without Power Steering With AC		
PN829C	Alternator Belt (RE).....	38.00/ea.
PN829D	Air Conditioning Belt (RE)	38.00/ea.
1964 All V8 With Power Steering, Without AC (First Design)		
PN829F	Alternator/Power Steering Belt (RE).....	38.00/ea.

Note: First design uses a two-groove pulley on both the alternator and power steering pump. 2 belts required.

1964 All V8 With Power Steering, Without AC (Second Design)		
PN829G	Alternator Belt (RE).....	38.00/ea.
PN829H	Power steering Belt (RE).....	38.00/ea.

Note: Second design uses separate drive belts for the alternator and the power steering pump. Each has a single groove pulley.

1964 All V8 With Power Steering, With AC		
PN829J	Alternator/Power Steering Belt (RE).....	38.00/ea.

Note: This pulley arrangement requires only one drive belt for the alternator and power steering pump.

PN829K	Air Conditioning Belt (RE)	38.00/ea.
1965 All V8 Without Power Steering, Without AC		
PN830A	Alternator Belt (RE).....	38.00/ea.
1965 All V8 Without Power Steering, With AC		
PN830B	Alternator Belt (RE).....	38.00/ea.
PN830C	Air Conditioning Belt (RE)	38.00/ea.
1965 All V8 With Power Steering Without AC		
PN830D	Alternator Belt (RE).....	38.00/ea.
PN830F	Power Steering Belt (RE)	38.00/ea.
1965 All V8 With Power Steering, With AC		
PN830G	Alternator/Power Steering Belt (RE).....	38.00/ea.

Note: This pulley arrangement requires only one drive belt for the alternator and power steering pump.

PN830H	Air Conditioning Belt (RE)	38.00/ea.
1966 All V8 Without Power Steering, Without AC, Without A.I.R.		
PN831A	Alternator Belt (RE).....	38.00/ea.
1966 All V8 Without Power Steering, With AC, Without A.I.R.		

PN831B	Alternator Belt (RE).....	\$38.00/ea.
PN831C	Air Conditioning Belt (RE)	38.00/ea.
1966 All V8 With Power steering, Without AC, Without A.I.R.		
PN831D	Alternator Belt (RE).....	38.00/ea.
PN831F	Power Steering Belt (RE)	38.00/ea.
1966 All V8 With Power Steering, With AC, Without A.I.R.		
PN831G	Alternator Belt (RE).....	38.00/ea.
PN831H	Power Steering Belt (RE)	38.00/ea.
PN831J	Air Conditioning Belt (RE)	38.00/ea.
1967 All V8 Without Power Steering, Without AC, Without A.I.R.		
PN832A	Alternator Belt (RE).....	38.00/ea.
1967 All V8 Without Power Steering, With AC, Without A.I.R.		
PN832B	Alternator Belt (RE).....	38.00/ea.
PN832C	Air Conditioning Belt (RE)	38.00/ea.
1967 All V8 With Power steering, Without AC, Without A.I.R.		
PN832D	Alternator Belt (RE).....	38.00/ea.
PN832F	Power Steering (RE)	38.00/ea.
1967 All V8 With Power Steering, with AC, Without A.I.R.		
PN832G	Alternator Belt (RE).....	38.00/ea.
PN832H	Power Steering Belt (RE)	38.00/ea.
PN832J	Air Conditioning Belt (RE)	38.00/ea.

Note: For 1966-67 A.I.R. (Air Injection) applications, please inquire.

1968 All V8 Without Power Steering, Without AC		
PN833A	Alternator Belt (RE).....	38.00/ea.
1968 All V8 Without Power Steering, With AC		
PN833B	Alternator Belt (RE).....	38.00/ea.
PN833C	Air Conditioning Belt (RE)	38.00/ea.
1968 All V8 With Power Steering, Without AC		
PN833D	Alternator Belt (RE).....	38.00/ea.
PN833F	Power Steering Belt (RE).....	38.00/ea.
1968 All V8 With Power Steering, With AC		
PN833G	Alternator Belt (RE).....	38.00/ea.
PN833H	Power Steering Belt (RE)	38.00/ea.
PN833J	Air Conditioning Belt (RE)	38.00/ea.
1969 All V8 Without Power Steering, Without AC		
PN834A	Alternator Belt (RE).....	38.00/ea.
1969 All V8 Without Power Steering, With AC		
PN834B	Alternator Belt (RE).....	38.00/ea.
PN834C	Air Conditioning Belt (RE)	38.00/ea.
1969 All V8 With Power Steering, Without AC		
PN834D	Alternator Belt (RE).....	38.00/ea.
PN834F	Power Steering Belt (RE).....	38.00/ea.
1969 All V8 With Power Steering, With AC		
PN834G	Alternator Belt (RE).....	38.00/ea.
PN834H	Power Steering Belt (RE)	38.00/ea.
PN834J	Air Conditioning Belt (RE)	38.00/ea.
1970 All V8 Without Power Steering, Without AC		
PN835A	Alternator Belt (RE).....	38.00/ea.
1970 All V8 Without Power Steering, With AC		
PN835B	Alternator Belt (RE).....	38.00/ea.
PN835C	Air Conditioning Belt (RE)	38.00/ea.
1970 All V8 With Power Steering, Without AC		
PN835D	Alternator Belt (RE).....	38.00/ea.
PN835F	Power Steering Belt (RE).....	38.00/ea.
1970 All V8 With Power Steering, With AC		
PN835G	Alternator Belt (RE).....	38.00/ea.
PN835H	Power Steering Belt (RE)	38.00/ea.
PN835J	Air Conditioning Belt (RE)	38.00/ea.
1971 All Without Power Steering, Without AC		
PN836A	Alternator Belt (RE).....	38.00/ea.
1971 All Without Power Steering, With AC		
PN836B	Alternator Belt (RE).....	38.00/ea.
PN836C	Air Conditioning Belt (RE)	38.00/ea.
1971 All With Power Steering, Without AC		
PN836D	Alternator Belt (RE).....	38.00/ea.
PN836F	Power Steering Belt 50 1/2" Long (RE) ...	36.00/ea.
1971 All V8 With Power Steering, With AC		
PN836G	Alternator Belt (RE).....	38.00/ea.
PN836H	Power Steering Belt 50 1/2" Long (RE) ...	38.00/ea.
PN836J	Air Conditioning Belt (RE)	38.00/ea.

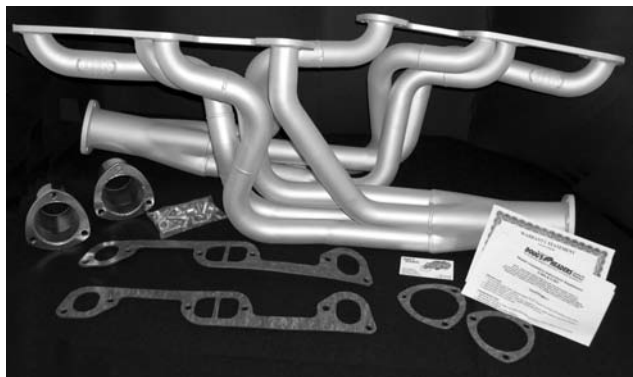

PN399H 1965-68 D-Port Headers (AP)..... \$569.00/pr.

Note: PN399H is a reproduction D-Port Header made with 1 3/4" tubes and 3" collectors. Polished ceramic coating is also available at an additional cost.

Additional discounts do not apply to headers.

Quality: Excellent.

Add \$40.00 oversize fee to standard shipping for headers.



EXHAUST MANIFOLDS & COMPONENTS

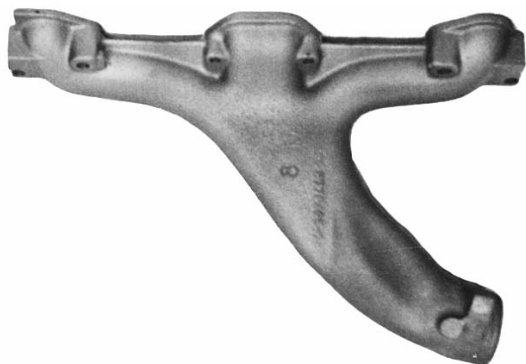

PN403

All exhaust manifolds are manufactured using high-quality ductile iron. Manifolds have passed heat testing from -52°F to 1400°F and also passed the difficult quench test. Manifolds are warranted for one year on materials and workmanship. For **round-port or Edelbrock** aluminum cylinder head applications, use PN403F or PN403J.

Manifolds are supplied with steel studs and brass nuts. Stainless studs are available (see PN422 and PN422A).

Additional discounts do not apply to exhaust manifolds.

Add \$25.00 oversize fee to standard shipping for PN403 and \$40.00 for PN403B.



PN403 1965-68 D-Port HO Longbranch Exhaust Manifold - All, Pair 2 1/4" (RE)..... 469.00/pr.

Note: Please contact us concerning 1962-64 and 69-72 full-size applications.

PN403 1969 D-Port HO Longbranch Exhaust Manifold - All, Pair 2 1/4" (RE)..... 469.00/pr.

Note: PN403 will also fit 1970-72 GP although they are not original equipment.

PN403B 1966-69 D-Port RA Longbranch Exhaust Manifold, Pair 2 1/2" (RE)..... 469.00/pr.

PN403F 1965-69 & 1969-72 GP Round-Port HO Longbranch Exhaust Manifolds (RE)..... \$649.00/pr.

PN403F is an exact reproduction of the 1968 Ram-Air II and 1969 Ram-Air IV castings originally made by Pontiac. Fits Edelbrock aluminum head applications or original round - port heads.

Note 1: Gaskets, studs, and other hardware are not included and must be purchased separately. The PN403C flanges and PN427 oil filter adapter are required with PN403F as well as the possible need for a shorter starter solenoid or the PN423P high-torque starter.

Note 2: Ceramic coating in cast gray or polished silver internally and externally is also available for an additional \$199.00.

PN403J 1965-69 & 1969-72 GP Super Round-Port HO Longbranch Exhaust Manifolds (RE)..... 725.00/pr.

PN403J manifolds exhibit the same features as the PN403F with re-engineered oversized 3" collectors for increased flow. Please read all notes under PN403F.

Add \$25.00 oversize fee to standard shipping for PN403F and PN403J.



PN403A

PN403A HO Exhaust Flange (2-Bolt) (RE)..... 21.00/ea.

Note: This 2-bolt flange must be used with PN403 exhaust manifolds.

Comments: Excellent.

PN403C Oversized HO Exhaust Flange (2-Bolt)(RE) 27.00/ea.

Note: This 2-bolt flange must be used with PN403F & PN403J exhaust manifolds.

PN406J 1968-74 Exhaust Flange - All V8 exc. HO (AP)... 9.00/ea.



PN422

PN422 1955-77 Exhaust Manifold Stud and Nut exc. Long Branch Manifolds (RE) 4.00/ea.

PN422A 1965-69 Long Branch Manifold Stud and Nut (RE) 4.50/ea.

These studs and nuts should be used with new exhaust flanges or when your HO or RA header pipe is changed. With these stainless steel studs and bronze nuts you will rid yourself of broken flange studs and exhaust manifolds.



PN407

PN407 1955-72 Exhaust Manifold Coating, Pint (AP)..... 25.00/pr.

PN407A 1955-72 Exhaust Manifold Coating, Aerosol (AP) 16.00/ea.

This high-quality Eastwood product is an excellent dressing for original manifolds as well as these new reproductions. Fortified with 25% stainless steel, this high-temperature coating will give your manifolds new cast-iron appearance for thousands of miles. Aerosol is 11.7oz.

PN407E Metallic Ceramic Polish, 6oz (AP)..... 18.00/ea.



Exhaust manifold coating cannot be shipped by air or outside the Continental United States.

Exhaust manifold components continue on next page.

Exhaust manifold components continued.



PN410J

PN408 1965-69 HO Exhaust Manifold Installation Kit (RP) \$31.00/kit

Note: PN408 contains one pair of Fel-Pro high-performance sandwich gaskets and grade 8 high-tensile bolts.

PN410 Round-Port Exhaust Manifold Installation Kit (RP) 29.00/kit

PN410J D-Port Standard Exhaust Manifold Installation Kit (RP) 31.00/kit

Please tell us how many and what size your bolts are when ordering this kit since there are many different combinations.

Note: Same components as PN408 above.

PN411 1959-77 High Performance D-Port Exhaust Manifold Gasket (AP) 26.00/pr.

PN411 is one pair of Fel-Pro high-performance gaskets.

PN411A 1959-77 D-Port Standard Exhaust Manifold Gasket, Steel (RP) 14.00/pr.



PN413

PN413 1955-77 Exhaust Manifold Bolt Lock (APE) 2.00/ea.

This lock was used on all V8 exhaust manifold bolts.



PN414

PN414 1963-68 Exhaust Manifold Heat Control Valve Anti-Rattle Spring - All V8 (RE) 8.00/ea.



PN415

PN415 1956-58 Exhaust Elbow - LH (RE) 88.00/ea.

PN415 was used on all 1956 cars w/dual exhaust and 1957-58 cars with dual exhaust but without fuel injection. This piece is often cracked or broken.

Comments: Excellent reproduction.

PN415C 1958 Exhaust Elbow w/ T395A Engine - RH (RE) 88.00/ea.

This elbow fits only 330HP tri-power cars w/ dual exhaust. Casting # 530966.

PN416 1961-64 Exhaust Elbow - RH (RE) 88.00/ea.

This was used on 1961-62 cars equipped with the 425A engine and 1963-64 421 HO engines.

EXHAUST PRE-HEATER COMPONENTS



PN386L

PN386L 1968-74 Standard Exhaust Pre-Heater Shroud (RE) 79.00/ea.



PN386R

PN386R 1968-77 Pre-heater Shroud to Air Cleaner Duct and Elbow (GM) \$17.00/ea.

This duct comes complete with elbow. The duct is of the correct black accordion-style material.



PN387



PN387P

PN386X 1968-77 Pre-heater Shroud to Air Cleaner Elbow (GM) Disc.

PN387 1968-77 Pre-heater Elbow to Air Cleaner Clamp (RE) 2.00/ea.

PN387P 1968-77 Air Cleaner duct to Preheater Shroud Pinch Clamp (RE) 3.50/ea.

Most original clamps are missing or have been replaced by an incorrect substitute. We now offer this correct reproduction.

FLOWMASTER EXHAUST

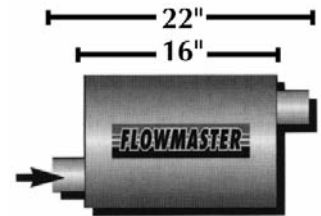
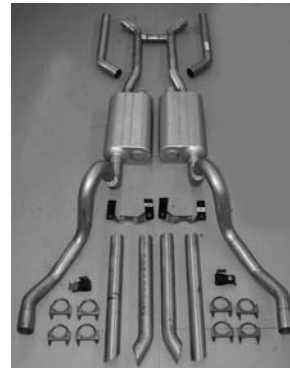

PN17119

PN17107 1969-72 2 1/2" Exhaust System w/o Mufflers - GP (AP) 359.00/set

PN17119 1969-72 American Thunder 2 1/2" Complete Exhaust System with Mufflers - GP (AP) . 489.00/set

Note: For 17107 & 17119 fabrication is needed to adapt header pipes to exhaust manifolds or headers.

Add \$45.00 oversize fee to standard shipping for PN17107 & PN17119.

PN15802 1969-72 2 1/2" Tailpipes - GP (AP) 169.00/pr.

Flowmaster mufflers use a fully aluminized 16 gauge steel welded case which is virtually indestructible. These mufflers greatly improve combustion efficiency and offer optimum street performance.

PN42453 1955-77 2 1/4" Three chamber Muffler - All Pontiac V8 (AP) 119.00/ea.

PN42553 1955-77 2 1/2" Three chamber Muffler - All Pontiac V8 (AP) 129.00/ea.

Three-chamber mufflers give a mellow more conservative tone over two-chamber mufflers without sacrificing performance.

PN42443 1955-77 2 1/4" Two chamber Muffler - All Pontiac V8 (AP) 90.00/ea.

PN42543 1955-77 2 1/2" Two chamber Muffler - All Pontiac V8 (AP) 90.00/ea.

For those seeking a more aggressive sound we suggest using these two-chamber mufflers.

Add \$7.50 oversize fee to standard shipping for each muffler and \$15.00 for tailpipes.

BATTERY CABLE SHIELDS



PN423J



PN423K

- PN423J** Battery Cable Heat Shield (4") (RE) \$11.00/ea.
PN423K Battery Cable Heat Shield (4 1/2") (RE) . 11.00/ea.

These original-style heat shields bolt to the driver's side head and run down behind the exhaust manifold.

Note: These cable shields fit a variety of V8 full-size cars.



PN423NB

- PN423NB** 1969 GP HO Positive Battery Cable Shield (APE) 32.00/ea.

All '69 GP HO positive cables were routed originally through a tube attached to the LH motor mount (Part #9789780). They are a necessity for both the restored and street driven HO cars since they keep the cable away from the hot exhaust manifolds.

STARTERS & COMPONENTS



PN424

- PN423NG** 1961-64 High-Torque Starter- All Pontiac V8 (AP) 209.00/ea.

Note: This starter bolts to the bell housing.

- PN423P** 1965-77 High-Torque Starter - All Pontiac V8 w/ Long Branch HO Manifolds (AP)..... 209.00/ea.
PN424 1965-77 High-Torque Starter - All Pontiac V8 Exc. Long Branch HO Manifolds (AP).... 209.00/ea.

As we all know, Pontiacs have a common hot-start problem. These high torque, lightweight, compact designs produce in excess of 525 ft. lbs of torque (Stock is about 190 ft. lbs) The special heat-dissipating solenoid makes for easy and consistent starts. These starters come with bolts and shims.



PN425D

PN425G

- PN425D** 1965-77 Starter Mounting Bolt (GM) 5.50/ea.
PN425G Starter Shim (Use as required) (RP) 1.50/ea.
PN425J 1966-69 Starter Support Brace (RE) 19.00/ea.
PN429 OK-2 Inspection Stamp (RE) 18.00/ea.



PN424D

- PN424D** 1965-77 AC/Delco Starter - All V8 (GM) 119.00/ea.
PN424DA 1965-77 Remanufactured Starter, All V8 (RP) 69.00/ea.

PN424D & PN424DA require a \$20.00 refundable core charge. Core must be rebuildable and returned in original box.



PN424G

- PN424G** 1965-77 Starter Solenoid - All V8 (GM) \$41.00/ea.
PN423 Solenoid Heat Shield (RE) 12.00/ea.

Originally designed for the '67 HO applications, this stainless shield helps insulate your starter solenoid from exhaust manifold heat. Shield can be used on any Pontiac to help reduce hot start problems and prolong solenoid life.



PN423

DISTRIBUTORS & COMPONENTS



PN526AD

PN526AG

- PN526AD** 1962-73 Points Type Remanufactured Distributor, All Pontiac V8 exc. TI or Unitized (RP) 68.00/ea.

This distributor comes complete with vacuum advance, points set, condenser, lead wire and advance weights. Cap and rotor are not included.

PN526AD requires a \$15.00 refundable core charge. Core must be rebuildable and returned in original box.

- PN526AG** 1974-77 HEI Remanufactured Distributor, All Pontiac V8 (RP) 145.00/ea.

This distributor comes complete with vacuum advance, module, lead wires and advance weights. Cap, rotor, module and coil are not included.

Note: PN526AD and PN526AG are replacement distributors. They will not have correct date codes or part numbers. These distributors carry a 90-day warranty.

PN526AG requires a \$20.00 refundable core charge. Core must be rebuildable and returned in original box.



PN526AJ



PN526AM

- PN526AJ** 1957-73 Points Set, Clip-on Type Terminal, All Pontiac V8 (AC-Delco) 16.00/ea.
PN526AM 1957-73 Condenser, All Pontiac V8 exc. TI or Unitized (AC-Delco) 5.50/ea.

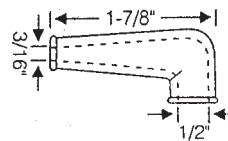

PN267J



PN269J

- PN267J** 1961-62 Generator and Ignition Coil Electrical Connection Boot (RE) 14.00/ea.
PN269J Starter, Generator, and Distributor Tag Fasteners (RE) 2.00/ea.

These are the little round-headed, fluted shank rivets that attach various tags to starters, generators, and early distributors. A must-have detail item for the purist.

- PN269J** 1957 Generating Mounting Bracket (RE) 32.00/ea.



PN268K

PN268K 1962-74 Alternator Plastic End Cap - Red (RE) \$9.00/ea.

PN268L 1962-74 Alternator Plastic End Cap - Black (RE) 9.00/ea.

PN268M 1975-77 Alternator Plastic End Cap - Black (GM) 3.50/ea

PN268K and PN268L are exact reproductions of the plastic caps used on all alternators. Cap covers positive lead and is a necessity for detailed restorations.

For Alternators see page114.



PN526AQ

PN526AQ 1957-73 Rotor, All Pontiac V8 exc. TI or Unitized (AC-Delco) 5.50/ea.

PN526BC 1974-77 Rotor, All Pontiac V8 w/ HEI (AC-Delco) 7.00/ea.

PN526BF 1957-73 Distributor Cap, All Pontiac V8 exc. TI or Unitized and 1957 3x2(AC-Delco).. 14.00/ea.

Although these Delco caps are visually correct, they do not have the same markings as originals.



PN526BF



PN526BR

PN526BR 1974-77 HEI Ignition Coil Cover - All Pontiac V8 (AC-Delco)..... 17.00/ea.

PN526BS 1974-77 HEI Ignition Distributor Module - All Pontiac V8 (AC-Delco)..... 39.00/ea.



PN526BS



PN526BG

PN526BG 1957-73 "Delco-Remy" Distributor Cap - All Pontiac V8 Exc. TI and Unitized Dist. and 57 3x2 (RE)..... 53.00/ea.

PN526BG is a correct reproduction with "Delco-Remy Patent Pending" script.

PN526BH 1967 Transistorized Ignition "Delco Remy" Distributor Cap, Red - All w/ TI (NOS/Delco) 49.00/ea.

PN526BH is NOS and has the correct "Delco Remy" script along with "PATENT" and number. PN526BH is the correct red cap used on 1967 cars equipped with transistorized ignition.

PN526BJ 1974-77 Distributor Cap, All Pontiac V8 w/ HEI (AC-Delco) 21.00/ea.

PN526BK 1959-73 Distributor Recurve Kit (AP)..... 12.00/ea.

For points distributors only. Comes with 3 sets of springs, 2 curve weights and instructions.



PN526BK



PN526BL

PN526BL 1960-73 Vacuum Advance (RP) 17.00/ea.

This will work for 1968 but does not have the two ports like originals. PN526BL fits points-type distributors only.

PN526BKC 1960-73 High-Performance Vacuum Advance Kit (AP) 44.00/kit

PN526BKC is an Accel adjustable vacuum advance kit that allows fine tuning of the advance to specific applications. Instructions are included.

PN526BLA 1974-77 Vacuum Advance, HEI Only (RP)..... 19.00/ea.



PN526BKC



PN526BM

PN526BM 1960-73 Ignition Coil, -All Pontiac V8 exc. TI or Unitized (AC-Delco) \$43.00/ea.

This is a Delco replacement coil. It is visually correct except it does not have the same markings as originals.

PN526BP 1974-77 HEI Ignition Coil -All Pontiac V8 (AC-Delco)..... 59.00/ea.



PN526BP



PN526BV

PN526BV Late 66-69 Ignition Coil Bracket - FS(RE)..... 42.00/ea.

This bracket bolts to the rear of the passenger side cylinder head.

PN526BW 1969-71 Ignition Coil Bracket - GP (RE) 42.00/ea.

PN526BW 1970-71 Ignition Coil Bracket - FS (RE) 42.00/ea.

This bracket mounts to the throttle cable bracket.



PN526AA

PN526AA 1955-77 Distributor Hold Down Clamp, All Pontiac V8 (RE)..... 10.00/ea.

PN526AB 1955-77 Distributor to Block Gasket (AP) 2.00/ea.



PN526AB



PN526AJF

PN526AJF 1968-69 Distributor Vacuum Control Valve, All MT (NOS)..... 109.00/ea.

PN526AJF has the correct black plastic cover. Bracket is not plated. This is used on all manual transmission applications and controls the type of vacuum going to the vacuum advance. During deceleration, this valve changes from ported vacuum to manifold vacuum allowing maximum advance. This helps combustion - which reduces emissions.

PN526BLC 1970-71 TCS Solenoid W/Bracket All V8 (RE) 99.00/ea.

PN526BLD 1970-74 Transmission TCS Switch All 4SP (RE) 32.00/ea.

PN526BLG 1970-74 TCS Switch Wire Retainer, All 4SP (RE) .. 19.00/ea.



PN526BLC

SPARK PLUG WIRES

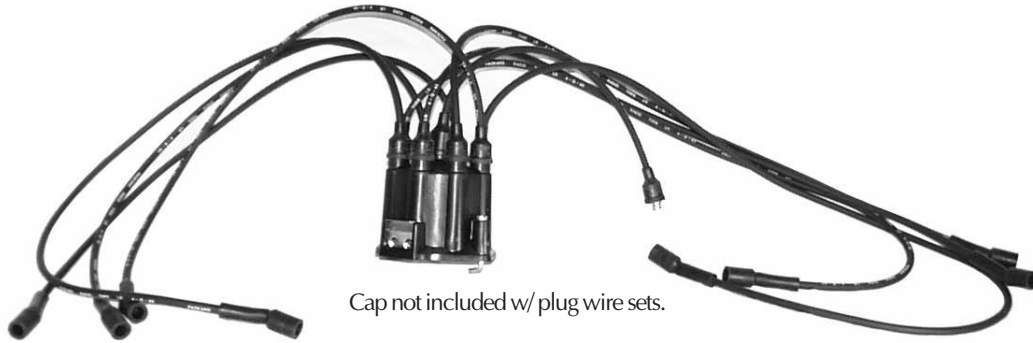

Cap not included w/ plug wire sets.

Original-style date coded plug wires used during the 60's and early 70's greatly improve your restoration. We lost our manufacturer for 2nd and 4th quarter wires about a year ago. We are currently working on locating a new manufacturer and hope to have these wires in the near future.

Dating Information: Original wires used various printings like the above example. "TVRS" means Television Radio Suppression. The date code consists of a number designating the quarter, "Q" denoting quarter, and the last two digits indicate the year. The wire photographed above was made in the second quarter of 1963. Original wires were manufactured 1 month to 1 year AHEAD of the actual automobile assembly date. Order your correctly dated wires by subtracting one to twelve months from your car's assembly date. This date is stamped on the cowl tag. Example: a 1966 car with "04C" (third week of April) on the tag can use wires with either 4Q65, or 2Q66 codes.

PN525AT	Spark Plug Wire Set 1-Q-61 (RE)	\$76.00/set
PN525AV	Spark Plug Wire Set 3-Q-61 (RE)	76.00/set
PN525AW	Spark Plug Wire Set 1-Q-62 (RE)	76.00/set
PN525AX	Spark Plug Wire Set 3-Q-62 (RE)	81.00/set
PN525A	Spark Plug Wire Set 2-Q-63 (RE)	Inquire
PN525BL	Spark Plug Wire Set 3-Q-63 (RE)	79.00/set
PN525B	Spark Plug Wire Set 4-Q-63 (RE)	Inquire
PN525CL	Spark Plug Wire Set 1-Q-64 (RE)	79.00/set
PN525C	Spark Plug Wire Set 2-Q-64 (RE)	Inquire
PN525DL	Spark Plug Wire Set 3-Q-64 (RE)	79.00/set
PN525D	Spark Plug Wire Set 4-Q-64 (RE)	Inquire
PN525EL	Spark Plug Wire Set 1-Q-65 (RE)	79.00/set
PN525E	Spark Plug Wire Set 2-Q-65 (RE)	Inquire
PN525FL	Spark Plug Wire Set 3-Q-65 (RE)	79.00/set
PN525F	Spark Plug Wire Set 4-Q-65 (RE)	Inquire
PN525GL	Spark Plug Wire Set 1-Q-66 (RE)	79.00/set
PN525G	Spark Plug Wire Set 2-Q-66 (RE)	Inquire
PN525HL	Spark Plug Wire Set 3-Q-66 (RE)	79.00/set
PN525H	Spark Plug Wire Set 4-Q-66 (RE)	Inquire
PN525JL	Spark Plug Wire Set 1-Q-67 (RE)	79.00/set
PN525J	Spark Plug Wire Set 2-Q-67 (RE)	Inquire
PN525KL	Spark Plug Wire Set 3-Q-67 (RE)	79.00/set
PN525K	Spark Plug Wire Set 4-Q-67 (RE)	Inquire

Note: 2Q66 or 4Q66 wires should be used on all '67 model cars to insure proper fit and correct length wires. 2Q67 wires are used only on early production '68 models.

PN525LL	Spark Plug Wire Set 1-Q-68 (RE)	79.00/set
PN525L	Spark Plug Wire Set 2-Q-68 (RE)	Inquire
PN525ML	Spark Plug Wire Set 3-Q-68 (RE)	79.00/set
PN525M	Spark Plug Wire Set 4-Q-68 (RE)	Inquire
PN525NL	Spark Plug Wire Set 1-Q-69 (RE)	79.00/set
PN525N	Spark Plug Wire Set 2-Q-69 (RE)	Inquire
PN525OL	Spark Plug Wire Set 3-Q-69 (RE)	79.00/set
PN525O	Spark Plug Wire Set 4-Q-69 (RE)	Inquire

Note: 1969 model year applications with air conditioning require different wire sets - please inquire.

PN525PL	Spark Plug Wire Set 1-Q-70 (RE)	79.00/set
PN525P	Spark Plug Wire Set 2-Q-70 (RE)	Inquire
PN525QL	Spark Plug Wire Set 3-Q-70 (RE)	79.00/set
PN525Q	Spark Plug Wire Set 4-Q-70 (RE)	Inquire
PN525RL	Spark Plug Wire Set 1-Q-71 (RE)	79.00/set
PN525R	Spark Plug Wire Set 2-Q-71 (RE)	Inquire
PN525SL	Spark Plug Wire Set 3-Q-71 (RE)	79.00/set
PN525S	Spark Plug Wire Set 4-Q-71 (RE)	Inquire
PN525SA	Spark Plug Wire Set 1-Q-72 (RE)	76.00/set
PN525SAE	Spark Plug Wire Set 3-Q-72 (RE)	76.00/set

PN525SAG	Spark Plug Wire Set 1-Q-73 (RE)	\$76.00/set
PN525SAJ	Spark Plug Wire Set 3-Q-73 (RE)	76.00/set
PN525SAL	Spark Plug Wire Set 1-Q-74 (RE)	76.00/set

Note: These plug wire sets are custom cut to the correct lengths and do not fit cars with unitized distributors. They are a must for the purist.

NON DATE CODED WIRES

PN525AA	1955-56 Spark Plug Wire Set All w/o 2-4bbl (RE)	81.00/set
PN525AC	1956-57 Spark Plug Wire Set w/ 2-4bbl. or 3-2bbl (RE)	76.00/set
PN525AE	1957 Spark Plug Wire Set w/ Fuel Injection (RE)	70.00/set
PN525AG	1957 Spark Plug Wire Set w/ Single Carb (RE)	70.00/set
PN525AJ	1958 Spark Plug Wire Set w/ Fuel Injection (RE)	70.00/set
PN525AL	1958 Spark Plug Wire Set w/o Fuel Injection (RE)	81.00/set
PN525AN	1959-60 Spark Plug Wire Set w/ Single Carb (RE)	76.00/set
PN525AP	1959-60 Spark Plug Wire Set w/ 3-2bbl (RE)	76.00/set
PN525AR	1961 Spark Plug Wire Set All (Not Dated) (RE)	70.00/set

Note: PN525AA through PN525AR are not available with date codes.

PN525AZ	1962-63 Spark Plug Wire Set - (Not Dated) Super Duty (RE)	76.00/set
---------	---	-----------

Note: PN525AZ uses solid core wires that will result in radio interference.

AC-DELCO® REPLACEMENT PLUG WIRE SETS

PN525SAQ	1955-73 Universal Spark Plug Wire Set All V8 - A/C Delco (AP)	31.00/set
PN525SAT	1974-77 HEI Ignition Plug Wire Set (AC Delco)	43.00/set

These Packard wires are Delco replacements. They may not have the same configurations or markings as originals.



PV885	Dielectric Grease, 1 oz (GM)	11.50/ea.
-------	------------------------------------	-----------

Used to protect electrical terminals from moisture.

AC-DELCO® SPARK PLUGS



PN525SC	1959-66 Spark Plug, All 389cid (AC-Delco).....	\$3.00/ea.
PN525SF	1962-66 Spark Plug, All 421cid (AC-Delco).....	3.00/ea.
PN525SJ	1967-69 Spark Plug, All 400cid (AC-Delco).....	3.00/ea.
PN525SM	1967-69 Spark Plug, All 428cid (AC-Delco).....	3.00/ea.
PN525SP	1970-71 Spark Plug, All Pontiac 350cid and 400cid 4bbl (AC-Delco).....	3.00/ea.
PN525SS	1970-71 Spark Plug, All 400cid 2bbl (AC-Delco).....	3.00/ea.
PN525SV	1970-71 Spark Plug, All 455cid (AC-Delco).....	Disc.
PN525SY	1972-74 Spark Plug, All Pontiac 350cid and 400cid 2bbl (AC-Delco).....	3.00/ea.
PN525TA	1972-74 Spark Plug, All 400cid 4bbl and 455cid (AC-Delco).....	3.00/ea.
PN525TD	1975-77 Spark Plug, All Pont. 350cid 2bbl and 400cid 2bbl (AC-Delco).....	3.00/ea.
PN525TG	1975-77 Spark Plug, All Pontiac 350cid 4bbl. and 400cid 4bbl. (AC-Delco).....	3.00/ea.
PN525TJ	1975-76 Spark Plug, All 455cid (AC-Delco).....	3.00/ea.

SPARK PLUG WIRE LOOMS

Plating on metal brackets may vary within kits.



PN520A

PN520	1962-63 Spark Plug Wire Loom Brackets and Retainers (RE).....	53.00/set
<i>Note: Consists of two brackets and three retainers.</i>		
PN520A	1964 Spark Plug Wire Loom Brackets and Retainers, 2 and 4 bbl (RE).....	34.00/set
<i>Note: Consists of two brackets and three retainers.</i>		
PN520AA	1964 Spark Plug Wire Loom Brackets and Retainers, Tri-Power (RE).....	54.00/set
<i>Note: Consists of two brackets and three retainers.</i>		
PN520B	1965 Spark Plug Wire Loom Brackets and Retainers (RE).....	54.00/set
<i>Note: Consists of two brackets and three retainers.</i>		
PN520C	1966 Spark Plug Wire Loom Brackets and Retainers (RE).....	54.00/set
<i>Note: Consists of two brackets and three retainers.</i>		
PN520D	1967 Spark Plug Wire Loom Brackets and Retainers (RE).....	54.00/set
<i>Note: Consists of two brackets and three retainers.</i>		



PN520E

PN520E	1968-69 Spark Plug Wire Loom Brackets -exc. '69 w/AC (RE).....	\$65.00/set
<i>Note: Consists of six neoprene coated brackets.</i>		
PN520F	1969 Spark Plug Wire Loom Brackets -w/AC (RE).....	65.00/set
<i>Note: Consists of six neoprene coated brackets.</i>		
PN520H	1970 Spark Plug Wire Loom Brackets (RE)....	65.00/set
<i>Note: Consists of six neoprene coated brackets.</i>		
PN520J	1971-77 Spark Plug Wire Loom Retainers (RE) ...	11.00/set
<i>Note: This kit is for cars w/o HEI systems. Consists of four retainers.</i>		



PN523J

PN523J	1955-56 Spark Plug Wire Retainer (RE).....	7.00/ea.
PN525	1961-67 Spark Plug Wire Retainer (4-Wire) (GM).....	4.00/ea.



PN525



PW138K	"How to Build High-Performance Ignition Systems" by Todd Ryan.....	25.00/ea.
---------------	--	-----------

How to Build High-Performance Ignition Systems is the complete guide to understanding automotive ignition systems, from old-school points and condensers to modern computer-controlled distributorless systems, from bone-stock to totally aftermarket.

Author Todd Ryden leads you through the various components, systems, and subsystems, explaining the theory behind how the parts work with each other to achieve the ultimate goal of efficient combustion. Coils, wires, spark plugs, distributors, magnetos, inductive systems, CD ignitions, multiple-spark systems, computer ignition controls, and rev limiters are explained using clear text and 275 color photos and wiring diagrams.

This book will help you understand how your car's ignition works, and it will help you choose the right components for your car's performance needs.

PERTRONIX ELECTRONIC IGNITION SYSTEM



PN525TV



PN525TVA

Wouldn't it be great to gain the benefits of electronic ignition while retaining your Pontiac's stock appearance? It is possible with this Pertronix solid-state electronic ignition system. The ignitor converts your points-type distributor over to electronic in just minutes without removal of the distributor. The only giveaway that this is non-OEM is the extra wire going to the coil. Test results show the ignitor delivers twice the voltage to the spark plugs, increasing horsepower, fuel economy and plug life. The ignitor can be used with the OEM coil, wires and spark plugs. For maximum performance we offer the Flame Thrower 40,000 volt coil as well as the Flame Thrower low-resistance high-performance plug wires. The Flame Thrower coil and wires come in black to retain that stock appearance.

These kits do not include coil or wires.

Ignitors are warranted to be free from defects in materials and workmanship for a 30 month period from the date of purchase.

- PN525TV** 1957-74 Pertronix Ignitor Kit All exc. HEI (AP).... \$71.00/kit
PN525TVA 1957-74 Pertronix Ignitor II Kit All exc. HEI (AP)..... 99.00/kit

The Ignitor II senses coil levels and automatically adjusts dwell to maintain peak energy throughout the entire RPM range. The Ignitor II is recommended for high RPM applications.

- PN525TVC** 1964-73 Pertronix Ignitor III Kit All exc. HEI (AP) 139.00/kit

The new Ignitor III kit offers the same convenience of the Ignitor II with the added convenience of an adjustable rev limiter. Simple to adjust, this limiter can be set to any RPM range or disabled if needed. The Ignitor III is compatible with stock points distributors. Highly recommended for demanding high-performance situations.



PN525TW



PN525TZ

- PN525TW** 1955-74 Flame Thrower Coil, Black, All exc. HEI (AP)..... 30.00/ea.

With 40,000 available volts this coil delivers an average of 15% more spark energy and voltage over OEM. PN525TW can be used with the factory points ignition and OEM wires.

- PN525TX** 1955-74 Flame Thrower II Coil, Black, All exc. HEI (AP)..... 33.00/ea.

PN525TX delivers 45,000 volts and is intended for use on Pertronix Ignitor II systems only. It will not work on capacitive discharge or distributorless ignitions.

- PN525TZ** 1960-74 Flame Thrower High Performance Spark Plug Wires, Black, All exc. HEI (AP) 41.00/set

These high-performance 7.0 MM low-resistance plug wires come in black with no print for that stock look. PN525TZ can be used with factory points ignition.

- PN525V** 1957-77 Pertronix Digital Rev Limiter (AP)..... 129.00/ea.

MSD® PERFORMANCE IGNITION



PN525WA



PN525WC

- PN525WA** MSD Pro-Billet Electronic Distributor, All Pontiac V8 exc. 301 (AP)..... \$399.00/ea.

Special features include a fully adjustable mechanical advance assembly for stable timing, a 1/2" hardened distributor shaft supported by sealed ball bearings, and a high-output magnetic trigger pickup used to supply the ignition with a trigger signal.

Note: PN525WA must be used with the MSD "6" series ignition box (PN525WF or PN525WJ). Does not accept a vacuum advance.

- PN525WC** Blaster II Performance Coil (AP)..... 45.00/ea.

If you are looking to upgrade your stock coil or want to complement your MSD "6" series ignition, the Blaster II coil is the right choice.

PN525WC has a red housing.



- PN525WF** MSD "6" Series Ignition Box w/o Rev Limiter (AP)..... 209.00/ea.
PN525WH MSD "6AL" Series Ignition Box w/ Built-in Rev Limiter (AP)..... 309.00/ea.

MSD pioneered the multiple sparking capacitive discharge ignition system. The increased spark that the MSD system delivers across the plug gap will improve the drivability and performance of "daily-drivers" as well as Saturday-night-racers.

Benefits: Quick starts, increased power, smooth idle, crisp throttle response, and reduced plug failure.

- PN525WJ** MSD 8.5mm Super Conductor Spark Plug Wire Set, All V8 - Black (AP)..... 109.00/set

PN525WJ has the spark plug side boots and terminals installed. The distributor side boots and terminals are included but not yet crimped on. Included in each set is a mini stripper/crimper for easy installation.

- PN525WM** MSD Tach Adaptor (AP) 69.00/ea.

If your tach does not read properly after installing your MSD box, this MSD tach adaptor will be needed. This is common on some reproduction and aftermarket tachometers such as Autogage, VDO, and Sun. Please inquire for usage on our reproduction tachometers.

M&H SINGLE WIRE ELECTRONIC IGNITION



- PN525XC** 1957-74 Single Wire Breakerless Ignition (AP).... 149.00/ea.

ENGINE MOUNTS



PN548

PN548	1955-57 Engine Rear Support Mount (RE).....	\$79.00/pr.
PN550A	1959-64 Engine Mount - LH (AP).....	22.00/ea.
PN550B	1959-64 Engine Mount - RH (AP).....	22.00/ea.
PN550	1965-70 Engine Mount - FS, LH or RH (AP).....	19.00/ea.
PN550A	1969 Engine Mount - GP, LH (AP).....	22.00/ea.
PN550B	1969 Engine Mount - GP, RH (AP).....	22.00/ea.
PN551L	1970-73 Engine Mount - GP, LH (AP).....	19.00/ea.
PN551R	1970-73 Engine Mount - GP, RH (AP).....	19.00/ea.
PN551L	1971-72 Engine Mount - FS w/HD Frame, LH (AP)	19.00/ea.
PN551R	1971-72 Engine Mount - FS w/HD Frame, RH (AP)	19.00/ea.
PN553	1973-76 Engine Mount - FS, LH or RH (AP).....	26.00/ea.
PN555	1974-77 Engine Mount - GP, LH or RH (AP).....	16.00/ea.

PN553 & PN555 bolt to the frame.

MITY MOUNTS©



PN550M	1965-70 Mity Mount Engine Mount, Pair, All FS (AP)	99.00/pr.
PN550P	1970-73 Mity Mount Engine Mount, Pair, GP (AP)	99.00/pr.
PN550P	1971-72 Mity Mount Engine Mount, Pair, FS w/HD Frame (AP).....	99.00/pr.

ENGINE CRADLE



PV340

PV340	Pontiac Engine Cradle (AP).....	129.00/ea.
--------------	---------------------------------	------------

These cradles are excellent for storing and moving your Pontiac engine blocks or complete engines. Built from square tubing they have 4 casters for maneuverability. Cradles are rated for 900 pounds and are very stable.

Add \$5.00 oversize fee to standard shipping for engine cradles



OIL FILTER COMPONENTS



	PN390L	PN390R	PN390RD	
PN390K	1960-66 Correct PF7 Oil Filter (RE).....			\$27.00/ea.
PN390L	1967-74 Correct PF24 Oil Filter (RE).....			22.00/ea.
PN390P	1960-77 Replacement AC PF24 Oil Filter -All Pontiac V8 (GM).....			7.00/ea.
PN390R	1960-77 Replacement AC Small Diameter Oil Filter, All Pontiac V8 (GM).....			7.00/ea.

Used for aftermarket header applications where clearance is tight.

PN390RD	1964-77 Oil Filter Housing Gasket (AP).....	3.00/ea.
PN390RK	1971-77 Oil Filter Housing Bolt Kit (AP).....	6.00/ea.



PN427

PN427	1965-68 Oil Filter Adapter w/ HO Exhaust - FS (RE).....	85.00/ea.
PN428	1969 Oil Filter Adapter w/ HO Exhaust - GP (RE).....	57.00/ea.

Note: These reproduction adapters are cast aluminum. They must be used when installing HO exhaust manifolds PN403 on your engine.



	PN390RA	PN390RC	PN390RF	
PN390RA	Joe Gibbs 10W-30 Synthetic Motor Oil, Quart (AP)			9.50/ea.
PN390RC	Joe Gibbs 15W-50 Synthetic Motor Oil, Quart (AP)			9.50/ea.
PN390RF	Joe Gibbs Synthetic Brake-In Motor Oil, Quart (AP)			7.50/ea.

Joe Gibbs Driven hot rod oil is designed specifically for hot rod and muscle car applications. Born from the company's successful formulation of high-performance racing oils and lubricants, these oils are also used by Joe Gibbs Racing Sprint Cup and Nascar Nationwide Series teams. This new oil will protect your car on the street, track, and in your garage.

Their high levels of zinc provide proper anti-wear protection for flat tappet lifters and camshafts.

Provides improved cold start protection, contains the same additive technology used by the US Military for storing and shipping combat equipment, and protects against rust and corrosion during storage and operation.

ENGINE COMPONENTS

OIL DIPSTICKS & TUBES

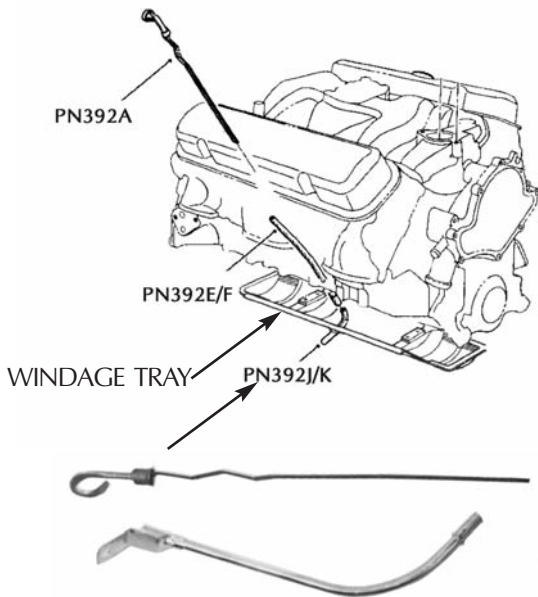

- PN391R 1964-65 Oil Dipstick, All V8 exc. AC (RE)..... Inquire
- PN391S 1964-65 Oil Dipstick, All V8 w/ AC (RE)..... Inquire
- PN392A 1968-77 Oil Dipstick, All Pontiac V8 exc. AC (GM)\$15.50/ea.
- PN392C 1968-77 Oil Dipstick, All Pontiac V8 w/AC (GM) 15.50/ea.
- PN392D 1961-63 Upper Dipstick Tube (RE) 31.00/ea.
- PN392D 1964-65 Upper Dipstick Tube w/o AC (RE) 31.00/ea.

Note: PN392D tube pushes over the PN392DN intermediate tube and runs up the passenger side of the block and has a bracket that mounts to the front valve cover bolt.

- PN392DB 1969 Upper Dipstick Tube, W/AC (APE) 32.00/ea.
- PN392DN 1955-56 Intermediate Dipstick Tube (RE) 13.00/ea.
- PN392DN 1959-65 Intermediate Dipstick Tube (RE) 13.00/ea.

Note: This short tube presses from the inside of the block out and connects to the PN392D upper tube. This is not the tube that is inside the pan.

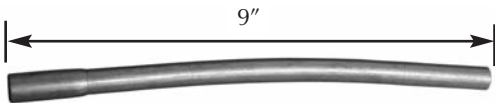

PN392E

- PN392E 1966-77 Oil Dipstick Tube to Block, All w/Pontiac V8 w/o AC - Stainless Steel (APE) 29.00/ea.
- PN392F 1966-77 Oil Dipstick Tube to Block, All Pontiac V8 w/AC - Stainless Steel (APE) 29.00/ea.

Note: The oil pan must be removed to install PN392E or PN392F. These tubes are visible on the outside of the block but are pushed up through from the inside.



PN392G

- PN392FG 1966-68 Oil Dipstick Tube, Upper w/AC - All Pontiac V8(RE)..... \$31.00/ea.
- PN392G 1970-77 Oil Dipstick Tube, Upper w/AC - All Pontiac V8 (APE)..... 17.00/ea.

Note 1: PN392G fits into PN392F.

Note 2: PN392G can also fit 1969 cars with some modifications to the mounting bracket.



PN392J

- PN392J 1965-68 Oil Dipstick Tube in Pan - All Pontiac V8 (APE)..... \$20.00/ea.

Our new stainless steel lower tube has not been available for years from GM (PN 9778483). Wall thickness and outside dimensions are exact along with the 39° angle to correctly orient the early dipstick.

Quality: Excellent.



PN392K

- PN392K 1969-73 Oil Dipstick Tube in Pan w/o Mounting Bracket - All Pontiac V8 (APE)..... 20.00/ea.

Our reproduction combines stainless steel with correct dimensions.

Quality: Excellent.



PN392L

- PN392L 1972-77 Oil Dipstick Tube in Pan w/ Mounting Bracket - All Pontiac Engine (APE)..... 22.00/ea.

GM also raised their price on this tube to over \$40.00. We've combined stainless steel with correct dimensions and angles for less than half their cost. We also tig-welded the bracket for added strength.

Quality: Excellent.

- PN392N 1977 V8 Oil Dipstick Tube - 305U (GM) 18.00/ea.



Harry's Tech Tip Replacing Dipstick Tubes...

As simple as it may sound, replacing dipstick tubes in Pontiacs is, by far, the subject of most of our tech calls and one of the most talked about subjects in our tech department. Most Pontiacs use 2 tubes (One inside the oil pan & one outside). The outer tube needs to be installed from the bottom up, which will require removal of the oil pan. The "pressed-fit" of the tube in the block acts as an oil seal. Once in place, the lower tube will fit loosely in the outer tube and the windage tray will slide over the lower tube holding it in place. GM incorporated a baffled oil pan mid-year 1972 eliminating the need for a windage tray. In these applications, the lower tube has a welded-on bracket that bolt to a main bearing cap. Air conditioned cars typically had a third (upper) extension tube added for easier access around the AC compressor. This also required a longer dipstick. As always, if you have any questions, feel free to call one of our technical advisors.

1-800-421-2637

OIL PANS & COMPONENTS



PN393

PN393 1968-77 Oil Pan - All Pontiac V8 (AP) \$189.00/ea.

This is a stock-appearing high performance oil pan with horizontal baffles and flat rails for optimal sealing. Use PN394J gasket set for 1968-71. This will also fit 1959-63 but appearance is not correct.

Note: For 1972-77 applications, the rear main section on the pan must be slotted to accept the five tab seal. The three-tab seal has been known to blow out causing a severe leak. Use PN394K gasket set for 1972-77.

PN393D 1968-71 Oil Pan - All Pontiac V8 (RE)..... 109.00/ea.

PN393 & PN393D will not work on 1964-67 cars.



PN393F

PN393F 1972-77 Oil Pan w/ Baffle - All Pontiac V8 (RE).. 129.00/ea.

Note: For 1972-77 applications, this pan must be modified to accept the 5-tab rear seal. using the 3-tab seal for these years may result in seal malfunction. Use PN394K gasket set for 1972-77.



PN394B

PN394B 1955-77 Oil Pan Drain Plug - All Pontiac V8 (GM) 5.00/ea.

Note: This has a 9/16" Hex head unlike the original 11/16".

PN394C 1955-77 Oil Pan Drain Plug Seal - All Pontiac V8 (RP)1.50/ea.



PN394C



PN394E

PN394E 1965-77 Oil Pan Mounting Reinforcement Brackets, 2 Piece Set (APE) 11.00/set

These brackets were introduced in a dealer tech bulletin 5/28/70 to fix the rear pan leak. Highly recommended if missing.



PN394G

PN394G 1959-77 "Correct" Oil Pan Bolt Kit, All Pontiac V8, 17 Pieces (APE)..... \$20.00/set

This new reproduction is now available with the correct 7/16" hex head design.

Quality: Excellent

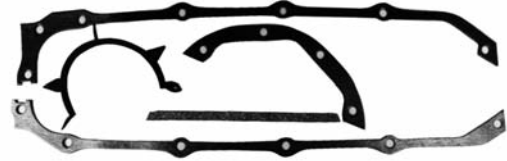

PN394J

PN394J 1959-Early '76 Oil Pan Gasket - All Pontiac V8 (AP) ... 21.00/set

PN394K Late 1976-77 Oil Pan Gasket - All Pontiac V8 (AP) ... 21.00/set

These gasket sets contain the three types of rear pan seals. '59-'71 uses the cork gasket (PN394J); '72-'76 (early) uses the three pronged seal (PN394J); and '76 (late)-'77 uses the five prong seal (PN834K).



PN394L

PN394L 1964-77 Oil Pan Gasket, One Piece (AP)..... 50.00/ea.

This new one-piece gasket will virtually eliminate the possibility of leaks that are common with the 4-piece original gasket sets.

Note: This steel-core neoprene gasket will need to be bent downward in the front where the oil pan meets the timing cover.

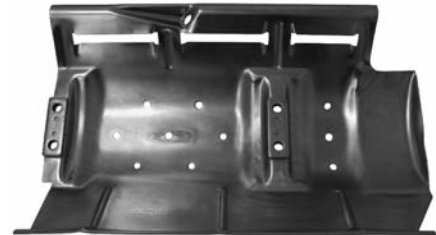

PN395

PN395 1965-73 Windage Tray - All Pontiac V8 (RE) 79.00/ea.

PN395 is a correct reproduction of the shorter style windage tray used from 1965-73 (15.5" long). Some 1972-73 cars did not have this tray originally as this was a transition period. This tray, however, is needed when using the PN392J or PN392K lower dipstick tube.



PN395K

PN395K 1965-73 Windage Tray Bolt Kit, All Pontiac V8 (RE) 2.00/kit

VALVE TRAIN COMPONENTS

EDELBROCK ALUMINUM HEADS

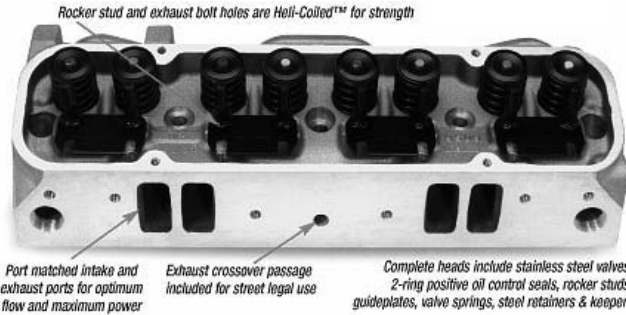

Designed for 1965-79 389-455 cid Pontiac engines, these are patterned after the 1969-70 Ram-Air IV Pontiac cylinder head. They produce outstanding horsepower with excellent low-end torque and throttle response. 87cc combustion chambers are designed to maximize performance with low-octane fuel delivering streetable compression ratios such as 9.5:1. The 72cc version is for higher compression engines. Both versions have a 5/8" deck for durability and head gasket retention.

Heads come complete with stainless steel valves (with swirl-polished undercut stems for excellent flow), valve springs and retainers, keepers, guide plates, and rocker arm studs. Does not include bolts, rocker arms, nuts or pushrods.

Combine these Edelbrock Heads with other Edelbrock components offered in this section for the Edelbrock "Total Power Package" No guess-work performance.

Note 1: With Edelbrock heads, OEM Round-Port exhaust manifolds (RA III, RA IV, 455 HO, or 455 SD) or Round-Port headers must be used.

Note 2: Stock head bolts will not work with these heads. Use PN613G.

No further discounts apply to heads.

Add \$20.00 oversize fee to standard shipping per cylinder head.

PN580 1965-77 389-455ci Aluminum Cylinder Heads - 87cc, Pair (AP) \$2,400.00/pr.

PN581 1965-77 389-455ci Aluminum Cylinder Heads - 72cc, Pair (AP) \$2,600.00/pr.

OEM CYLINDER HEADS & COMPONENTS



PN582 1969-70 Ram-Air IV Cast Iron Cylinder Heads, Pair (RE) Inquire

These OEM-style cast iron heads are in tooling. At press time, we have no ETA or quality notes. Please inquire. They will be available with the 722 or 614 casting numbers, however will not be date-coded.

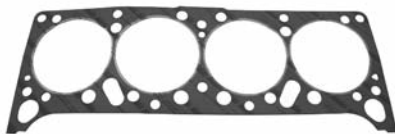

PN684 1958-77 Head Gasket, All V8 (2 required) (RP) .. 18.00/ea.



	PN613D	PN613BD	
PN613B	1964-66 Non-AC Head Bolt Set - 389 cid RE)		119.00/set
PN613D	1967-79 Heavy Duty Head Bolt Set, All 350-455 Exc. RA IV & 455-HO (RE).....		109.00/set
	PN613D does include stud bolts. Bolt head markings and appearance differ from originals.		
PN613G	Head Bolt Set - Edelbrock Aluminum Heads Only(AP).....		129.00/set
	These will not work with factory Pontiac cast iron heads.		
PN613BF	1967-77 Original-Style Head Bolt & Stud Kit, All Pontiac D-Port Heads (RE).....		99.00/set
PN613BD	1967-77 Original-Style Head Bolt & Stud Kit, All Pontiac Round-Port Heads (RE)		119.00/set

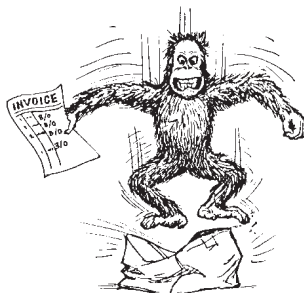

DON'T BACKORDERS MAKE YOU HOPPING MAD?

Needless backorders are aggravating, costly, and time-consuming. Each year, we've become more efficient reaching an unbelievably low backorder rate. Last year over 90% of all invoices were shipped without backorders and over 95% of all parts ordered were shipped without backorders.

If you want your parts NOW (and we mean all your parts), call: (800) 421-2637 (AMES). International calls, use: (603) 363-7000

www.amesperf.com



PN596

PN594 1964-66 1.5 Ratio Rocker Arm w/ Ball - All Pontiac V8 (RP)..... \$8.00/ea.

Note: Also fits 1967 326 and 400 2bbl.

PN596 1967-77 1.5 Ratio Rocker Arm w/ Ball & 3/8" Nut - All Pontiac V8 exc. 1967 326, 1967 400 2bbl., RA IV, 301 (RP) 8.00/ea.

PN598 1967-77 1.65 Ratio Rocker Arm w/ Ball & 3/8" Nut - All Pontiac V8, exc. 301 or 1967 400 2bbl (RP) Inquire

PN600 1967-77 1.65 Ratio Rocker Arm Set w/ Balls & 3/8" Nuts -All Pontiac V8, exc. 301 or 1967 400 2bbl (Set of 16) (RP) Inquire

We have found PN598 and PN600 to be a true 1.65 ratio rocker arm, which increases valve lift considerably over the stock 1.5 ratio.

Comments: Easy bolt-on performance. The best pressed steel rockers on the market.

PN602 1967-77 Rocker Arm Nut, 3/8", All Pontiac V8 exc. RA IV or 1967 400 2bbl (RP) ... 1.50/ea.

PN602R 7/16 Lock Nuts W/Set Screw for Aluminum Roller Rockers, 16pc (AP)..... 65.00/set



PN604

PN604 1967-77 Screw In Rocker Arm Stud, 3/8" Bottleneck, All Pontiac V8, exc. RA IV (RP)..... 6.00/ea.

PN605 1959-60 Pushrod - All 389 V8 (RP) 3.00/ea.

Note: Diameter: .315" Length: 9.145"

PN606 1961-66 Pushrod, All Pontiac V8 (RP)..... 3.00/ea.

Note 1: Also fits 1967 400 2bbl.

Note 2: Diameter: .315" Length: 8.715"

PN608 1967-77 Pushrod - All Pontiac V8, exc. 1967 400 2bbl., RA II & RA IV (RP) 3.50/ea.

Note: Diameter: .315" Length: 9.145"

PN609 1968 RA II Pushrod (RP) 3.50/ea.

Note: Diameter: .340" Length: 9.137"

Caution: Pushrod to guide hole interference may occur if PN609 is used with non RA II heads.

PN609B 1969-70 RA IV Pushrod (RP) 5.00/ea.

Note: Diameter: .340" Length: 9.205"

Caution: Pushrod to guide hole interference may occur if PN609B is used with non RA IV heads.

PN609D High Performance Chrome Molly Push Rod Set, 16pc (AP)..... 119.00/set

Note: Diameter: 03125" Length: 9.136"



PN610

PN610 1967-77 Pushrod Guideplate -All Pontiac V8 exc. RA II, RA IV, and 301 (AP)..... 15.00/set

Note: 1 set required per car.



PN612

PN612 Valve Spring Set for PN614 & PN616 Camshafts (RP)..... Inquire

PN612N Valve Spring Set for PN618 Camshafts (RP)..... Inquire

PN613 1963-77 Cylinder Head to Block Alignment Pin (GM)..... \$4.50/ea.

4 required per engine block.

CAMSHAFTS & COMPONENTS



PN614

A variety of cams are available for hundreds of different piston, head and valve train combinations, but we concentrate on factory specifications.

Our cams have stock duration, lift, overlap, and profiles for your original engine configuration.

Stock cams can also enhance performance. Please refer to the description of each shaft for your particular needs.

PN614 1959-77 Hydraulic Camshaft, OEM Replacement for GM # 9779066 (RP) .. 119.00/ea.

This camshaft replaces the standard horsepower workhorse cams from 1959 to 1976. The actual grind is a blueprint of the 9779066. Can also be used in 067 applications.

Performance Note: PN614 can be used in 326, 350, and low compression 400 engines if a modest performance increase is desired.

PN616 1959-77 Hydraulic Camshaft, OEM Replacement for GM # 9779068 (RP) .. 125.00/ea.

This is an exact profile for some of the finest stock street engines Pontiac ever engineered (1967-68 HO, 1968 Ram Air I, 1969-70 RA III, 1971-72 455 HO etc.).

Performance Note: Certainly the best for exact restoration, but also our choice for those individuals seeking horsepower increases from standard horsepower engines.

PN618 1959-77 Hydraulic Camshaft, OEM Replacement for GM # 9794041 (RP) .. 159.00/ea.

This is the famous RA II and RA IV shaft used in 1968-70 and originally scheduled for the 1973 Super Duty engines. This cam is the best choice for correct restorations.

Performance Note: This cam can produce large horsepower gains when installed in standard horsepower engines. However, be aware that the horsepower and torque bands are such that this cam is less streetable than the PN616.



PN624

PN624 1959-77 Camshaft Thrust Plate, All Pontiac V8 (APE) 24.00/ea.

PN626 1959-77 Camshaft Timing Gear Key, All Pontiac V8 (RP) 1.50/ea.

Camshafts & components continue on next page.

Camshafts & components continued.

EDELBROCK CAMSHAFTS & LIFTERS



PN619CA "Performer Plus" Cam Kit, All Pontiac V8 exc. 301 (AP)..... \$239.00/kit

PN619CA is designed for optimum torque from low-end to mid-range, smooth idle within operating range of idle to 5000rpm, increased throttle response and torque.

For Edelbrock's "Total Power Package", combine this cam with PN284HA Intake, PN458EC Carburetor, and PN580 or PN581 Heads.

Specs for PN619CA: Duration: 278°-Intake, 288°-Exhaust. Lift: .420-Intake, .442-Exhaust.

PN619CC "Performer RPM" Cam Kit, All pontiac V8 exc. 301 (AP)..... 259.00/kit

Designed for street high-performance applications, this cam provides power from 1500-6500rpm.

For Edelbrock's "Total Power Package", combine this cam with PN284HB Intake, PN458EC Carburetor, and PN580 or PN581 Heads.

Specs for PN619CC: **Duration**; 308°-Intake, 320°-Exhaust. **Lift**; .470-Intake, .470-Exhaust.

PN619CF "Torker Plus" Cam Kit, All pontiac V8 exc. 301 (AP)..... 259.00/kit

PN619CF is designed to work with PN284HC Torker II manifold for performance from 2500 to 6500rpm. "Torker-Plus" cams deliver a slightly rough idle.

For Edelbrock's "Total Power Package", combine this cam with PN284HC Intake, PN458EC Carburetor, and PN580 or PN581 Heads.

Specs for PN619CF: **Duration**; 298°-Intake, 304°-Exhaust. **Lift**; .465-Intake, .488-Exhaust.

Note 1: All Edelbrock cam kits come with hydraulic lifters, assembly lube, and instructions.

Note 2: We recommend replacing valve springs with the appropriate spring set listed for your cam kit.

No further discounts apply to Edelbrock Cam kits.

PN620 Camshaft Installation Tool (AP) 19.00/ea.

This tool allows easy installation of the camshaft without causing severe damage to cam bearings.



PN622

PN621 1969-70 RA IV Lifter Set (RP) Disc.

PN622 1959-77 Hydraulic Lifters, OEM Replacement, All Pontiac V8 exc. RA IV & 301 (RP).... 65.00/set

TIMING CHAINS & COMPONENTS



PN628

PN628 1959-77 Timing Chain and Gear Set - All Pontiac V8, exc. 301 (RP)..... \$41.00/set

PN630 1959-77 Double Roller Timing Chain & Gear Set - All Pontiac V8, exc. 301 (RP) 82.00/set

Performance Note: For more precise timing and durability we recommend using the PN630 or PN630A double roller timing chain set.



PN630A

PN630A 1967-79 Pro Billet Double Roller Timing Chain & Gear Set - All Pontiac V8, exc. 301 (RP) 99.00/set

The step design bronze bushing on PN630A frees up horsepower and reduces wear normally lost to friction at the cam plate. Crank sprocket has a 9-position keyway choice.

This timing chain set is one of the best on the market at an affordable price.



PN632

PN632 1959-77 Fuel Pump Eccentric - All Pontiac V8 (APE) 40.00/ea



PN634

PN634 1959-77 Camshaft Timing Gear Bolt - All Pontiac V8 (GM) 5.00/ea.



PN636

PN636 1959-77 Camshaft Timing Gear Bolt Washer -All Pontiac V8 (GM) 6.00/ea.

ENGINE COMPONENTS

ENGINE BEARINGS & CAPS



PN646

We have found Clevite 77 bearings to be by far the best rod and main bearings on the market. Because of their tri-metal construction they withstand the friction, dirt, wear, and heat that chew away bearing and journal life. We sell only standard size bearings.

- PN643** 1959-77 Cam Bearing Set, All Pontiac V8 exc. 301 (RP) \$36.00/set
- PN644** 1959-77 Standard Connecting Rod Bearing Set, All Pontiac V8 exc. 301 (RP) 75.00/set
- PN646** 1959-77 Standard Main Bearing Set, All Pontiac V8 exc. 421, 428 and 455 (RP). 89.00/set
- PN647** 1961-77 Standard Main Bearing Set, All Pontiac 421, 428 and 455 (RP)..... 96.00/set



PN650

- PN650** Plastigage, .001-.003 Clearance (AP)..... 2.50/ea.

Plastigage is used to measure bearing clearances. This is an absolute necessity when rebuilding an engine.



PN650C



PN650BD

- PN650C** GM Assembly Lube, 16 oz. (GM)..... 21.00/ea.

E.O.S. (GM Engine Oil Supplement) provides outstanding protection against run-in wear and piston scuffing, as well as run-in camshaft lobe and lifter scuffing resulting from insufficient lubrication.

- PN650BD** ZDDPlus Engine Oil Additive, 4oz. (AP) 10.00/ea.

With recent changes in engine oil mixtures, the crucial ZDDP molecule levels have been reduced to the point of causing concern among collector car enthusiasts. Without the ZDDP molecules, damage can occur to flat tappet camshafts, and with these debris from prematurely worn lobes floating through the lubrication system, further damage can result.

ZDDPlus puts "the good stuff" back in your engines oil, to help prevent premature wear and cam failure. One four ounce bottle per oil change treats regular or synthetic oil.

Also Available in 6-packs for \$55.00 and 12-packs for \$105.00

- PN650BF** Z-Paste Engine Assembly Lube..... 5.00/ea.

From the makers of ZDDPlus (PN650BD). Z-Paste is used for coating internal engine components such as camshafts, lifters, etc. Dissolves in initial breakin to protect all oiled engine components with ZDDP.

- PV880** Rust Penetrate & Inhibitor, 10.8 oz 8.00/ea.

Penetrates rust, lubricates and protects.

- PN651** 1963-77 Connecting Rod Bolt 3/8" - All Pontiac V8 exc. 455 Super Duty (GM) Disc.

- PN651G** 1963-77 Connecting Rod Nut 3/8" - All Pontiac V8 exc. 455 Super Duty (AP)..... Disc.



PN651J

- PN651J** 1963-77 Heavy Duty Connecting Rod Bolt Set w/ Nuts, 3/8" - All Pontiac V8, exc. 455 Super Duty (AP)..... \$99.00/set



PN652

- PN652** 1959-77 4 Bolt Main Bearing Cap Set - All Pontiac V8, exc. 421, 428 & 455(AP) ... 329.00/set

- PN653** 1962-76 4 Bolt Main Bearing Cap Set, All Pontiac 421, 428 & 455 (AP)..... 329.00/set

When non-4-bolt main blocks are fitted with PN652 - PN653 they must be drilled and tapped. All blocks must be line-bored.

OIL PUMPS & COMPONENTS



PN654

- PN654** 1959-77 Standard 60 PSI Oil Pump w/ Screen -All Pontiac V8, exc. 301 & RA IV (RP) 55.00/ea.

- PN656** 1959-77 80 PSI High Pressure Oil Pump w/ Screen - All Pontiac V8, exc. 301 (RP).. 79.00/ea.

- PN658** 1959-77 Oil Pump Drive Rod - All Pontiac V8, exc. 301, RA IV, 455 HO & 455SD - OE Replacement (RP)..... 10.00/ea.



PN658



PN658PT

- PN658PT** Oil Pump Primer Tool (AP) 19.00/ea.

10 1/4" long tool used for priming oil pump in the car. Attach to any drill and turn counter-clockwise to prime.

- PN660** 1959-77 Heavy Duty Oil Pump Drive Rod - All Pontiac V8, exc. 301 (RP) Disc.

PN660 was originally used on RA IV, 455 HO, and 455 SD. PN660 may be used in place of standard shaft.

PISTON RINGS

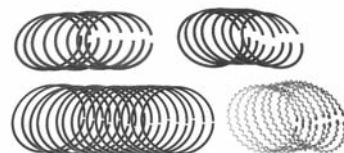

PN672

- PN662** 1959-66 389 cid Piston Ring Set, Standard(RP)... 72.00/set

- PN664** 1963-66 421 cid Piston Ring Set, Standard(RP)... 68.00/set

- PN666** 1968-77 Pontiac 350 cid Piston Ring Set, Standard (RP)..... 68.00/set

Piston rings continue on next page.

Piston rings continued.

PN668	1967-77 Pontiac 400 cid Piston Ring Set, Standard (RP).....	\$70.00/set
PN670	1967-69 Pontiac 428 cid Piston Ring Set, Standard (RP).....	70.00/set
PN672	1970-76 Pontiac 455 cid Piston Ring Set, Standard (RP).....	68.00/set

For years Sealed Power Rings have been the best OEM replacement available. They have a unique top ring design which helps seal against blow-by and provides excellent oil control.

Please Note: We sell only standard size rings.

PN683C	1959-77 Rope Style Rear Main Seal, All 326-400 Pontiac V8 (RP).....	\$7.00/ea.
PN683F	1962-76 Rope Style Rear Main Seal, All 421-455 Pontiac V8 (RP).....	9.00/ea.

PN683C and PN683F are replacement rope rear main seals. See PN683M & PN683P for improved designs of these seals.

PN683M	1959-77 Rope Style Rear Main Seal, All 326-400 Pontiac V8 (RE).....	21.00/ea.
PN683P	1962-76 Rope Style Rear Main Seal, All 421-455 Pontiac V8 (RE).....	22.00/ea.

PN683M & PN683P are new rope design rear main seals that are a great improvement over other aftermarket seals available. They closely match originals in effectiveness by being a larger diameter, heavier seal which results in a tight fit.

FREEZE PLUGS



PN674



PN676D

PN674	1959-77 Steel Freeze Plug Set, All Pontiac V8 (RP)	13.00/set
PN676	1959-77 Brass Freeze Plug Set, All Pontiac V8 (RP)	24.00/set
PN676D	1959-77 Cylinder Head Freeze Plug Set (RE).....	6.00/set

ENGINE GASKET OVERHAUL SETS



We recommend and use only Felpro gaskets for all applications from stock to highly modified. Their state of the art Perma Torque, Perma Seal construction gives a tight solid seal.

PN677	1958-60 Complete Engine Gasket Overhaul Set, All Pontiac V8 (RP).....	115.00/set
PN678	1961-66 Complete Engine Gasket Overhaul Set, All Pontiac V8 (RP).....	130.00/set

Note: This kit does not include a 1961-62 timing cover seal.

PN680	1967-77 Complete Engine Gasket Overhaul Set, All Pontiac V8 (RP).....	115.00/set
--------------	---	------------

Note 1: These kits do not fit 301, RA II, RA IV, 455 HO, or 455 SD. Please inquire about these applications.

Note 2: These kits do not contain any carburetor gaskets.



PN682

PN682	1959-77 326-400 cid Pontiac V8 Viton® Neoprene Rear Main Seal, Except 301 cid (AP).....	42.00/ea.
PN683	1962-76 421, 428, 455 cid Pontiac V8 Viton® Neoprene Rear Main Seal, w/3.25" Main(AP).....	42.00/ea.

These Viton® Pontiac neoprene rear main seals are direct replacements for the conventional rope seals which are prone to leak. Beware of X-brand seals on the market to fit Pontiacs. Viton® is strongly recommended.

Comments: Excellent longevity and performance.

HARMONIC BALANCERS & HARDWARE



PN688

PN687	1960-67 Harmonic Balancer, 2 Pc. All V8 (RE)...	179.00/ea.
--------------	---	------------

Since some aftermarket balancers have disintegrated in the past, we contacted SFI Laboratories to test this new product for rotational integrity. SFI Tested the balancer at 12,000 RPM for 1 hour with absolutely no sign of failure.

Note 1: Timing marks are at TDC and 6° BTDC for 1959-65 Specifications.

Note 2: PN687 includes heat-treated hub, nodular damper, optional retainer, hub-to-damper bolts, and crank key. It does not include the PN692 Balancer Bolt or PN693 Washer.

PN688	1968-77 Harmonic Balancer, All Pontiac V8 exc. RA IV and 301 (GM)	99.00/ea.
PN688A	1968-77 Harmonic Balancer, All Pontiac V8 exc. RA IV and 301 (RP)	Disc.

PN688A comes with crank key.

PN688HP	1968-77 High Performance Harmonic Balancer All Pontiac V8 exc.301 (AP)	139.00/ea.
----------------	--	------------

PN688HP is SFI approved and strongly recommended for high-performance applications. Hardware is not included.



PN690

PN692

PN690	1959-77 Harmonic Balancer Crank Key, All Pontiac V8 exc.RA IV and 301 (GM)	4.50/ea.
PN692	1959-77 Harmonic Balancer Bolt, All Pontiac V8 exc.RA IV and 301 (GM)	9.00/ea.
PN693	1959-77 Harmonic Balancer Washer, All Pontiac V8 exc.RA IV and 301 (GM)	5.00/ea.
PN695	1959-77 Harmonic Balancer Repair Sleeve (RP)	7.00/ea.

This sleeve repairs worn balancer hubs.

ENGINE COMPONENTS

ENGINE COMPARTMENT

ENGINE COMPARTMENT DETAILING PAINT



PP151



PP152



PP153



PP154



PP155AD



PP155AG



PP155AJ



PP192W



Aerosol paints cannot be shipped by air or outside the Continental United States.

PP151 Cast-Iron Spray Gray (AP)..... \$12.00/ea.

Ever wonder how those award winners keep cast-iron suspension components and master cylinders looking so new? There's a good chance those parts are painted with the Eastwood cast-iron spray paint (not heat-resistant).

PP152 "Aluma Blast" Aluminum Paint (AP)..... 12.00/ea.

Use this spray on any parts that need that clean original aluminum finish. Good for castings like transmissions.

PP153 Chassis Black, 15 oz. Aerosol (AP) 14.00/ea

This coating is used on the front A-arms and frame rails. We have found this epoxy-hardened, chip-resistant paint to be the best on the market.

PP154 Semi-Gloss Engine Compartment Paint (AP)..... 12.00/ea.

PP154 is a true semi-gloss paint available in a spray can. Usually a difficult paint to match, this Eastwood product is an excellent paint for engine compartment detailing.

PP155AD Charcoal Gray Zinc Phosphate, 11oz Aerosol (AP)..... \$12.00/ea.

This paint duplicates the OEM charcoal-gray zinc phosphate coating used on hood hinges, hood latches, shifter rods, and various suspension components.

PP155AG Silver Cad, 11oz Aerosol (AP)..... 12.00/ea.

PP155AG duplicates the bluish-silver tint of original cadmium plating used on carburetor linkages, alternator pulleys, transmission linkages, and other various applications.

PP155AJ Clear Zinc, 11oz Aerosol (AP) 12.00/ea.

PP155AJ duplicates the blue-gray OEM plating used on disc brake dust shields, coil brackets, throttle cable brackets, vacuum advances, relays, and various other applications.

Note: PP150 Through PP155AJ are high-quality Eastwood products.

PP192W Radiator Black, 12 oz. Aerosol (AP)..... 12.00/ea.

This is the correct high temp gloss black factory finish.

STRAPS & RETAINERS



PP101

PP101 P-4007 Black Nylon Compartment Strap, 2.75" (RP) \$2.00/ea.

PP101C P-4007 Black Nylon Compartment Strap, 3.75" (RP) 2.00/ea.

You'll find these straps holding various rubber hoses and wires in the engine compartment. These straps have raised letters denoting part #P-4007 and are correct length like originals.



PP102

PP102 Core Support Wire Retainers (APE)..... \$3.00/ea.

Many full-size cars used these retainers under the top of the core support. Not easily visible, these retainers hold the wires that cross the core support.

BATTERY TRAYS & COMPONENTS



PP111B

PP111B 1964 Battery Tray (RE) \$17.00/ea.

PP115B 1969-72 Battery Tray - GP (RE)..... 19.00/ea.

PP115E 1969-72 Battery Tray Bolt Kit, GP (RE)..... 2.00/ea.

This kit mounts the battery tray to the core support and inner fender well.



PP115J

PP115J 1969-72 Battery Detailing Package - GP (RE)..... 24.00/ea.

This package includes PP115B, PP115E, PP126, PP133 and PP134.



PP116

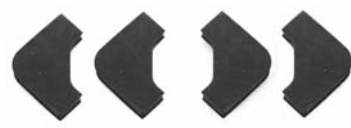

PP116B

PP116 1955-57 Battery Hold-Down Retainer (RP) \$15.00/ea.

This retainer is not exact but is very similar. Originals were made of four pieces spot-welded together while PP116 is stamped from one piece.

PP116B 1955-57 Battery Hold-Down Rubber Pads..... 5.50/set

These pads mount to the top of the battery to keep the metal hold-down away from the corrosive chemicals.



PP120



PP126

PP120 1958-63 Battery Hold-Down Clamp - Std. Battery (RE)..... 18.00/ea.
PP121 1964 Battery Hold-Down Clamp (APE)..... 18.00/ea.
PP122 1965 Battery Hold-Down Clamp (APE)..... 18.00/ea.
PP123 1966 Battery Hold-Down Clamp (APE)..... 18.00/ea.
PP125 1967-72 Battery Hold-Down Clamp - FS (APE)... 18.00/ea.
PP126 1969-72 Battery Hold-Down Clamp - GP (APE) . 5.50/ea.
PP126J 1973-77 Battery Hold-Down Clamp - All (APE).. 18.00/ea.

Original battery hold-downs become corroded and ruin the appearance of an engine compartment. These reproductions (exc. PP126) are made in our own shop using correct diameter steel rod. After fabricating these clamps to exact specifications they are dipped, producing the desired coating.

Comments: Very good.

PP129P 1955-57 Battery Hold-Down Bolt (RP)..... 3.50/ea.

Two of these bolts are needed with the PP116 retainer.



PP130



PP132A

PP130 1961-63, 66 Battery Hold-Down Bolt (APE)..... \$4.50/ea.
PP131 1964-65 Battery Hold-Down Bolt (APE)..... 6.00/ea.
PP132 1967-76 Battery Hold-Down Bolt - FS (RE)..... 8.00/ea.
PP133 1969-72 Battery Clamp Bolt - GP (GM)..... 1.00/ea.
PP132 1973-77 Battery Hold-Down Bolt - GP (RE)..... 8.00/ea.
PP132A Battery Tray Extruded U-Nut (RE) 1.00/ea.

PP132A is a 5/16"-18 U-nut used in various applications.



PP133C



PP133K



PP134

PP133C 1961-70 Battery Hold Down Starwasher (RE)..... 2.00/ea.
 This is the unique internal-external star lock washer used in conjunction with the PP133K to secure the battery hold down in place.
PP133K 1958-72 Battery Hold Down Flat Washer (RE).... 1.50/ea.
 PP133C and PP133K are commonly missing and seldom seen on the show car circuit. These are a must for any restoration and a great way to complement the engine compartment. PP133K is not lead impregnated as most originals were.
PP133P 1973-77 Battery Clamp Washer (RE)..... .50/ea.
PP133T 1973-77 Battery Clamp Nut (RE)..... .50/ea.
PP134 Extruded "U" Nut (5/16" x 18) (AP)..... 1.50/ea.

Similar to caged nuts, the "U" nuts are used on some battery trays, fan shrouds, etc.

RADIATORS - ALUMINUM DESERT COOLER™ RADIATORS

Tired of driving your Pontiac and nervously watching the temperature gauge? An aluminum Desert Cooler custom-fit performance radiator is just what you need. This aluminum radiator has 30% more cooling capacity than stock copper/brass radiators. The additional cooling is packed into the stock opening by utilizing thin 1" aluminum tubes in rows of 2. These Aluminum radiator cores have 60% more rows of tubes than the OEM copper/brass unit.

These fully welded units are direct fit; no metal modification needed. These are designed and built to bolt into the stock opening. Stock fan and shroud can be used without modification. For 1968-71 applications 4-core insulators must be used. 1968 3-core driver's side lower bracket must be modified as well. Desert Cooler Radiators are warranted against defects in material and workmanship for one year from date of purchase.

BEWARE of other aluminum radiators on the market that require extensive modifications for installation despite claims of being a bolt-in application.

No further discounts apply to aluminum radiators. Add \$39.00 oversize fee to standard shipping for radiators.

PP170AL 1961-64 Aluminum Desert Cooler - MT (RP)..... \$359.00/ea.
PP171AL 1961-64 Aluminum Desert Cooler - AT (RP)..... 359.00/ea.
PP180AL 1965-67 Aluminum Desert Cooler - MT w/Original 4-Core (RP)..... 399.00/ea.
PP180AAL 1965-67 Aluminum Desert Cooler - MT w/Original 3-Core (RP)..... 399.00/ea.
PP181AL 1965-67 Aluminum Desert Cooler - AT w/Original 4-Core (RP)..... 399.00/ea.
PP181AAL 1965-67 Aluminum Desert Cooler - AT w/Original 3-Core (RP)..... 399.00/ea.
PP182AL 1969-71 Aluminum Desert Cooler, MT - All (RP) 359.00/ea.
PP183AL 1969-71 Aluminum Desert Cooler, AT - All (RP) . 359.00/ea.

1965-67 Core Dimensions: Original 3 core radiators measure 26 1/4 x 17". Original 4 core radiators measure 26" x 17" - Please measure before ordering.

Note1: For some automatic applications the transmission cooling lines may need to be adapted to the fittings in the radiator. These adapters are included.

Note 2: Aluminum radiators are not painted or polished.

Note 3: Petcock is not included. Use PP193P or PP193T.



BRASS/COPPER DESERT COOLER™ 4-CORE RADIATORS

In an effort to help cure over-heating problems, we offer the finest radiators available. They are unique products designed and custom-manufactured for hot weather driving.

These radiators known, as "Desert Coolers", have more cooling fins than conventional radiators. They all utilize four-tube cores. If your car is now equipped with a four-core radiator these units bolt in with no modifications.

If your 1963-67 car has a three-core radiator, we offer a radiator that will bolt in with no modifications. You should not even consider using a three-core radiator in your Pontiac. Most Pontiac motors tend to run hot and need the added efficiency of four-core radiators.



Note: Limited warranty: US Radiator warrants its radiators to be free from defects in material plus workmanship for 1 year from date of purchase.

Note: All radiators must be **prepaid and are drop-shipped** directly from California. Please allow 4-5 weeks for delivery.

New tanks are used on all "Desert Coolers", however, they do not have the "Harrison" stamping. Radiators do not come with petcocks. Radiators must be re-painted if show quality is desired. Use PP192W.

Add \$39.00 oversize fee to standard shipping for radiators.

				
PP170	1961	Desert Cooler - MT (RP).....	\$419.00/ea.	PP180A 1965-67 Desert Cooler - MT w/Original 3-Core (RP)..... \$469.00/ea.
PP171	1961	Desert Cooler - AT (RP).....	419.00/ea.	PP181 1965-67 Desert Cooler - AT w/Original 4-Core (RP)..... 469.00/ea.
PP172	1962	Desert Cooler - MT (RP).....	419.00/ea.	PP181A 1965-67 Desert Cooler, AT w/Original 3-Core (RP)..... 469.00/ea.
PP173	1962	Desert Cooler - AT (RP).....	419.00/ea.	PP182 1969-71 Desert Cooler, MT - All (RP)..... 469.00/ea.
PP174	1963	Desert Cooler for Cars w/Original 3-Core Radiator - MT (RP).....	419.00/ea.	PP183 1969-71 Desert Cooler, AT - All (RP)..... 469.00/ea.
PP174A	1963	Desert Cooler for Cars w/Original 4-Core Radiator - MT (RP).....	419.00/ea.	PP182 and PP183 can be used for 1968 applications but driver's side lower insulator bracket will have to be modified to accept wider tank. Also must use PP195 insulators - '68 lower hose nipple should be 1 3/4" where these are 1 1/2".
PP175	1963	Desert Cooler for Cars w/Original 3-Core Radiator - AT (RP).....	419.00/ea.	PP184 1972-74 Desert Cooler, MT - FS (RP)..... 469.00/ea.
PP175A	1963	Desert Cooler for Cars w/Original 4-Core Radiator - AT (RP).....	419.00/ea.	PP185 1972-74 Desert Cooler, AT - FS (RP)..... 469.00/ea.
PP176	1964	Desert Cooler - MT (RP).....	419.00/ea.	PP186 1972 Desert Cooler, MT - GP (RP)..... 469.00/ea.
PP176A	1964	Desert Cooler 4 Core w/3 Core Tanks Originally - MT (RP).....	419.00/ea.	PP187 1972 Desert Cooler, AT - GP (RP)..... 469.00/ea.
		Use PP176A when your car originally had 3 Core tanks.		PP189 1975 Desert Cooler, AT - FS (RP)..... 469.00/ea.
PP177	1964	Desert Cooler - AT (RP).....	419.00/ea.	PP189A 1975 Desert Cooler, AT - GP (RP)..... 469.00/ea.
PP177A	1964	Desert Cooler 4 Core w/3 Core Tanks Originally - AT (RP).....	419.00/ea.	PP190 1976 Desert Cooler, AT - FS (RP)..... 469.00/ea.
		Use PP177A when your car originally had 3 Core tanks.		PP190A 1976 Desert Cooler, AT - GP (RP)..... 469.00/ea.
PP180	1965-67	Desert Cooler - MT w/Original 4-Core (RP).....	469.00/ea.	PP191 1977 Desert Cooler, AT - GP w/301, 305cid (RP)..... 469.00/ea.
				PP191A 1977 Desert Cooler, AT - GP w/300, 403cid (RP)..... 469.00/ea.



PP193 1968-72 Core Support - GP (RE) \$219.00/ea.

Must remove top plate and reuse original. GP top plate has an extra lip that these do not have.

Add \$80.00 oversize fee to standard shipping for PP193.



PP193K

PP193K Radiator Overflow Hose (RE) 1.50/ft.

This exact reproduction of the 3/8" ID hose with .075" wall is used in full-size applications not requiring an overflow bottle.



PP193P

PP193P Brass Radiator Petcock (GM) \$5.00/ea.



PP193T

PP193T Correct Style Fluted Brass Radiator Petcock (AP) 5.00/ea.

We have found many original low-mileage cars with this style petcock.



PP195

PP195 1969-77 Radiator to Core Support Insulators (GM) 26.00/pr.



PP195B 1969-77 Radiator to Core Support Insulators (RE) 10.00/pr.

PP195B is a less-expensive alternative to PP195. Quality on both is very good.



PP197

PP195C 1968-77 Radiator to Core Support Insulators w/2 5/8" Tank (RE)..... 12.00/pr.

PP197 1969-77 Radiator Core Support Bolt (RE) 1.00/ea.

ENGINE COMPARTMENT

RADIATOR CAPS



PP305A

PP305	1955-61	Radiator Cap, 13 PSI Cap (GM).....	\$10.00/ea.
PP305A	1955-61	Radiator Cap, Correct RC-6 13 PSI (RE)	26.00/ea.
PP306	1955-72	Radiator Cap, 15 PSI Cap (GM).....	16.00/ea.
PP306A	1955-63	Radiator Cap, Correct Early RC-15 15 PSI (RE)	26.00/ea.
PP306B	1964-72	Radiator Cap, Correct Late RC-15 15 PSI (RE)	26.00/ea.

PP305A, PP306A, and PP306B are exact reproductions of the original RC-6 and RC-15 caps. Probably more show points are lost because of incorrect replacement caps than any other single item. PP305 and PP306 are GM replacements. They do not have the same stamped surface nor the same wording as original.

PP306G	1955-72	Radiator Cap Gasket (RE).....	2.00/ea.
PP306J	1973-76	Radiator Cap, RC-33 (GM)	11.00/ea.
PP306L	1977	Radiator Cap (GM).....	10.00/ea.



PP158D



PV136

PP158D	Red-Line WaterWetter© Super Coolant Additive, 12oz (AP)	\$9.00/ea.
--------	--	------------

PP158D improves the ability of coolant to wet heat transfer surfaces by 50%. This provides better coolant contact in the cylinder head and can reduce coolant and head temperature by as much as 20 degrees. Water Wetter also cleans and lubricates water pump seals and reduces rust and corrosion. One 12 oz. bottle treats 12-16 quarts of coolant mix.

PV136	Anti-Freeze Tester (AP)	5.00/ea.
-------	-------------------------------	----------

PV136 Quickly tests the anti-freeze level in your cooling system. Reads in Fahrenheit and Celsius and is compatible with all types of coolants.

AIR CONDITIONING COMPONENTS

TYPICAL A/C SYSTEM

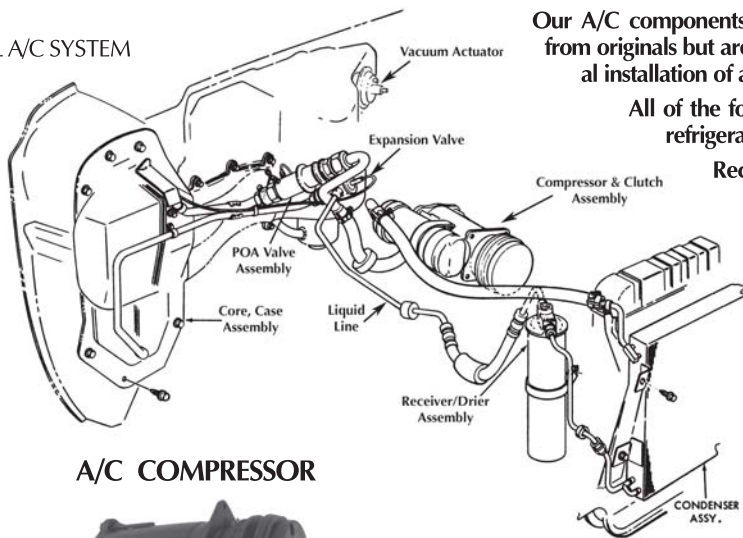

Our A/C components are replacements that may differ in appearance from originals but are functionally correct. We recommend professional installation of all A/C components.

All of the following A/C Components are compatible with all refrigerants.

Receiver driers must be replaced whenever replacing AC components that require system discharge to install.

Shipping Note: Some A/C components may not be stocking items, therefore will be drop-shipped from the manufacturer.

Some abbreviations you will find in this section are listed below:

- POA: Pilot Orifice Absolute
- ATC: Automatic Temperature Control
- VIR: Valve in Receiver
- STV: Suction Throttling Valve

A/C COMPRESSOR



PP198A

PP198A	1962-74	Air Conditioning Compressor, All w/o Super Heat Switch, Remanufactured (GM/RP)	\$225.00/ea.
PP198B	1971-76	Air Conditioning Compressor, All w/ Super Heat Switch, Remanufactured (GM/RP)	199.00/ea.



PP198AL	1964-74	Aluminum A/C Compressor (AP).....	\$399.00/ea.
---------	---------	-----------------------------------	--------------

****LIGHTWEIGHT ALUMINUM COMPRESSOR**.** WEIGHS 15LBS. NO CORE CHARGE OR ADDITIONAL SHIPPING.

This Pro6TEN Compressor is a 10 cylinder "bolt-in" direct replacement for the GM Frigidaire/Harrison A-6 compressor. This new design is specifically engineered to fit original A-6 mounting brackets and A/C hose assemblies. This highly efficient compressor offers a smoother, quieter operation, creating less vibration & engine drag, increased fuel mileage, and improved engine & cooling system performance. The aluminum body of the Pro6TEN is 52% lighter than the original A-6 (significantly reducing shipping costs). Designed to accept both Superheat and high pressure safety switches.

Note: You must re-use your original switch.

PP198C	1976-77	Air Conditioning Compressor, All w/o Super Heat Switch, Remanufactured (GM/RP)	199.00/ea.
--------	---------	--	------------

Note: Use PP198B for 1976 applications with superheat switch.

These remanufactured AC-Delco compressors come with the clutch assembly and are compatible with all automotive refrigerants.

Add \$8.50 **oversize fee** to standard shipping for PP198A through PP198C



ENGINE COMPARTMENT



PP198F

PP198F 1966-69 AC Compressor Spacers - All FS (RE) \$29.00/kit

A/C EVAPORATORS & CONDENSERS

Evaporators and AC condensers will be drop-shipped directly from the manufacturer.

Add \$8.50 oversize fee to standard shipping for evaporators and condensers.

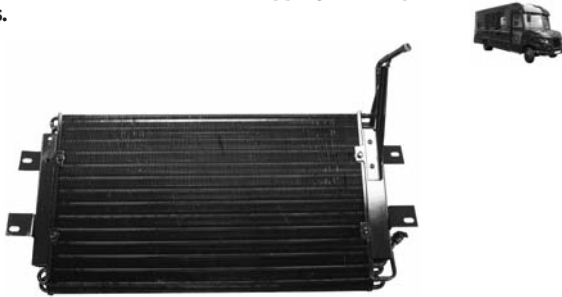

FULLSIZE EVAPORATORS

- PP198GA 1957 Air Conditioning Evaporator (AP) 355.00/ea.
- PP198GD 1962 Air Conditioning Evaporator (AP) 339.00/ea.
- PP198GG 1964 Air Conditioning Evaporator (AP) 355.00/ea.
- PP198GJ 1965 Air Conditioning Evaporator (AP) 339.00/ea.
- PP198GM 1966 Air Conditioning Evaporator (AP) 339.00/ea.

PP198GM fits cars with EA-5066B marked on the case.

- PP198GP 1967-70 Air Conditioning Evaporator
All exc. 1968-72 GP (AP) 329.00/ea.
- PP198GS 1971-73 Air Conditioning Evaporator
All exc. GP & 73 w/VIR (AP) 329.00/ea.
- PP198GV 1973-76 Air Conditioning Evaporator
All exc. GP & 73 w/Drier (AP) 299.00/ea.

1968-77 GRAND PRIX EVAPORATORS

- PP198KA 1968-72 Air Conditioning Evaporator-GP (AP) ... 309.00/ea.
- PP198KD 1973 Air Conditioning Evaporator
All GP w/Drier (AP) 329.00/ea.
- PP198KG 1973-76 Air Conditioning Evaporator
All GP & 73 w/VIR (AP) 339.00/ea.
- PP198KJ 1977 Air Conditioning Evaporator-GP (AP) ... 229.00/ea.



PP198L

PP198L 1968-77 Evaporator Pipe Sealing Tape (RP) 3.00/ea.

This sealing tape seals the evaporator core tube into the evaporator housing under the hood. Once this tape is wrapped around the pipe, it can be molded together with a heat gun or hair dryer to form a good seal.

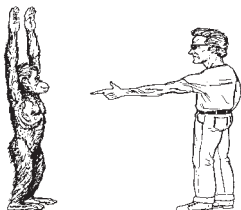

DON'T BE HELD UP BY PRICE INCREASES.

This may be the most important note you'll read in our catalog: We have kept our price increases to a **minimum**. Several products have even decreased in price.

For ordering or questions, call (800) 421-2637 (AMES).

FULLSIZE CONDENSERS

- PP198MA 1965 Air Conditioning Condenser(AP)..... Disc.
- PP198MD 1966 Air Conditioning Condenser(AP)..... \$309.00/ea.
- PP198MG 1967 Air Conditioning Condenser(AP)..... 315.00/ea.
- PP198MJ 1968-71 Air Conditioning Condenser
- All exc. GP (AP)..... 299.00/ea.
- PP198MQ 1971 Air Conditioning Condenser
- All exc. GP (AP)..... 309.00/ea.
- PP198MM 1972 Air Conditioning Condenser
- All exc. GP (AP)..... 319.00/ea.
- PP198MP 1973-74 Air Conditioning Condenser
- All exc. GP (AP) 319.00/ea.
- PP198MS 1975 Air Conditioning Condenser
- All exc. GP (AP) 309.00/ea.
- PP198MV 1976 Air Conditioning Condenser
- All exc. GP (AP) 309.00/ea.
- PP198MW 1976 Air Conditioning Condenser, w/ Slip-On
Fittings - All exc. GP (AP) 309.00/ea.
- PP198MX 1976 Air Conditioning Condenser, w/ "O-Ring"
Fittings - All exc. GP (AP) 309.00/ea.

1968-77 GRAND PRIX CONDENSERS

- PP198NA 1968-71 Air Conditioning Condenser- GP (AP)... 299.00/ea.
- PP198ND 1972 Air Conditioning Condenser- GP (AP)... 299.00/ea.
- PP198NG 1973-74 Air Conditioning Condenser- GP (AP)... 319.00/ea.
- PP198NH 1975 Air Conditioning Condenser
w/Slip-On Fittings- GP (AP)..... 319.00/ea.
- PP198NM 1976 Air Conditioning Condenser- GP (AP)... 299.00/ea.
- PP198NP 1977 Air Conditioning Condenser- GP (AP)... 309.00/ea.

Note: Condensers are located at the front of the radiator. Evaporators and condensers are compatible with all automotive refrigerants.

RECEIVER/DRIER



PP199AAA

- PP199AAA 1961-66 A/C Aluminum Receiver/Drier
Assembly (RE) 81.00/ea.
- PP199AA 1967 A/C Receiver/Drier Assembly (AP)..... 81.00/ea.
- PP199AD 1968-70 A/C Receiver/Drier Assembly -All (AP) . 81.00/ea.
- PP199AG 1971-72 A/C Receiver/Drier Assembly -
All Exc. GP (AP) 81.00/ea.
- PP199AJ 1971-72 A/C Receiver/Drier Assembly -
GP Only (AP) Inquire
- PP199AM 1973-76 A/C Receiver/Drier Assembly -
All w/ VIR (AP) 195.00/ea.
- PP199AP 1973-76 A/C Receiver/Drier Assembly -
All w/ VIR Eliminator Kit (AP) 165.00/ea.
- PP199AQ 1973-77 VIR Maintenance Kit (AP) 27.00/ea.

PP199AQ includes O-rings, pickup screen and XH-7 desiccant. POA and TXV valves are not include.

PP199AS 1977 A/C Receiver/Drier Assembly (AP)..... Inquire

Note 1: Receiver/Driers are compatible with all automotive refrigerants.

Note 2: Replacement driers may be from steel or aluminum and do not exhibit the same appearance as originals.

POA VALVE UPDATE & EXPANSION VALVE



PP199BG

- PP199BA** 1957-61 Hot Gas Bypass Valve Rebuild Kit- All w/Hot Gas Valve (AP) \$41.00/ea.
- PP199BD** 1962-65 Suction Throttle Valve (STV) Update- All w/STV (AP)..... 95.00/ea.
- PP199BG** 1965-70 POA Valve Update, All w/POA (AP) 119.00/ea.
- PP199BJ** 1971-73 POA Valve Update, All w/POA (AP)..... 115.00/ea.

These replace the original POA valves and convert to a more reliable cycling clutch system that improves A/C system performance with new automotive refrigerants. Updates come complete with valve assembly, wiring and instructions. Updates are compatible with all automotive refrigerants.

Replacement POA valves differ in appearance from original.



PP199BS

- PP199BM** 1958 A/C Expansion Valve Assembly, All w/ O-Ring Climate Valve#2554 (AP)..... Disc.
- PP199BP** 1958-67 A/C Expansion Valve Assembly, All w/ O-Ring Climate Valve#2554 (AP)..... 69.00/ea.
- PP199BS** 1962-73 A/C Expansion Valve Assembly, All exc. 1973 w/STV (AP)..... 65.00/ea.

Expansion valves are compatible with all automotive refrigerants.



PP199FA

- PP199FA** 1964-77 Air Conditioning "O" Ring Seal Kit (AP) 9.00/kit
- This kit includes all the "O" ring seals to service and entire A/C system. For use with all automotive refrigerants.

A/C VACUUM ACTUATORS AND COMPONENTS



PP199FN

- PP199FH** 1958-60 A/C Vacuum Actuator, Auxiliary Outlet (AP)..... 46.00/ea.
- PP199FK** 1961-62 A/C Vacuum Actuator, Inlet Duct Selector Air Valve (AP)..... 58.00/ea.
- PP199FN** 1961-62 A/C Vacuum Actuator, Inlet Duct Inside Air Valve (AP)..... 55.00/ea.

- PP199FQ** 1961-62 A/C Vacuum Actuator, Inlet Duct Outside Air Valve (AP)..... \$46.00/ea.
- PP199FT** 1963-64 A/C Vacuum Actuator, Inlet Duct Inside Air Valve (AP)..... 46.00/ea.
- PP199FW** 1963-64 A/C Vacuum Actuator, Inlet Duct Outside Air Valve (AP)..... 46.00/ea.
- PP199JA** 1965-68 A/C Vacuum Actuator, Inlet Lower (AP) 46.00/ea.
- PP199JD** 1969-70 A/C Vacuum Actuator, Air Inlet Valve Lower - All exc. GP & FS w/o ATC (AP). 46.00/ea.
- PP199JG** 1969-72 A/C Vacuum Actuator, Air Inlet Valve, Lower - All GP w/ATC (AP) 46.00/ea.
- PP199JJ** 1971-72 A/C Vacuum Actuator, Air Inlet Valve - All exc. GP (AP) Inquire
- PP199JM** 1973-75 A/C Vacuum Actuator, Air Inlet Valve - All exc. GP (AP) 46.00/ea.
- PP199JP** 1963-70 A/C Vacuum Actuator, Defroster Valve - All exc. GP (AP) 46.00/ea.
- PP199JS** 1971-75 A/C Vacuum Actuator, Defroster Valve - All exc. '72 GP (AP)..... 55.00/ea.



PP200AB



PP200AF

- PP200AB** 1959-72 A/C Vacuum Check Valve (RP)..... 11.00/ea.
- PP200AF** 1971-77 Vacuum Canister, All w/AC (RP)..... 21.00/ea.

HEATER CONTROL VALVES



PP201AP

- PP201AB** 1957 Heater Control Valve - All (AP)..... Disc.
- PP201AF** 1958 Heater Control Valve - All (AP)..... 95.00/ea.
- PP201AJ** 1959-61 Heater Control Valve - All (AP)..... Disc.

Note: PP201AB through PP201AJ are remanufactured valves and require a \$100.00 core charge.

- PP201AL** 1963-64 Heater Control Valve - All w/AC (AP) ... Disc.
- PP201AP** 1965-68 Heater Control Valve - All w/AC (AP) ... 29.00/ea.
- PP201AT** 1969-70 Heater Control Valve - All w/AC (AP) ... 29.00/ea.
- PP201AX** 1971-73 Heater Control Valve - All w/AC (AP) ... 29.00/ea.

BLOWER MOTOR RESISTORS & RELAYS

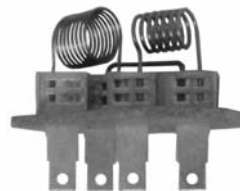

PP201BA



PP201BJ

- PP201BA** 1965-70 Blower Motor Resistor - All exc. ATC or GP (AP) 29.00/ea.
- PP201BD** 1969-71 Blower Motor Resistor - All GP exc. ATC (AP)..... Inquire
- PP201BJ** 1965-68 A/C Master Relay - All (AP) 19.00/ea.
- PP201BP** 1969-75 A/C Master Relay - All exc ATC (AP) 19.00/ea.

ENGINE COMPARTMENT

BLOWER MOTOR SWITCHES



- PP201FA** 1961-62 Blower Motor Switch -All w/AC (RE) \$49.00/ea.
PP201FJ 1969-72 Blower Motor Switch - All GP w/AC exc. ATC (RE)..... 49.00/ea.

CLIMATE CONTROL CABLES



- PP201JA** 1958 Climate Control Cable Set - All w/AC (RP)..... 27.00/set
PP201JD 1958 Climate Control Cable - All exc.AC (RP) 21.00/ea.
PP201JL 1962 Climate Control Cable Set - All w/AC (RP) 43.00/set
PP201KL 1969 Climate Control Cable Set - All exc. AC (RP)..... 55.00/set

HEATER CORES & BLOWER MOTORS

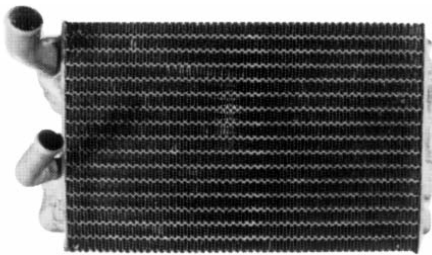

- PP204** 1961 Heater Core, w/o AC (AP)..... 155.00/ea.
PP204 1962 Heater Core, w/o AC (AP)..... 155.00/ea.
PP207 1963-64 Heater Core - All (AP)..... 125.00/ea.
PP210 1965-68 Heater Core, w/ AC (AP)..... 79.00/ea.
PP211 1965-68 Heater Core, w/o AC (AP)..... 85.00/ea.
PP212 1969-72 Heater Core, w/ AC - GP (AP) 68.00/ea.
PP213 1969-70 Heater Core, w/o AC - FS (AP)..... 85.00/ea.
PP213A 1969-72 Heater Core, w/o AC - GP (AP) 68.00/ea.
PP214 1971-76 Heater Core, w/ AC - FS (AP)..... 69.00/ea.
PP214 1971-76 Heater Core, w/o AC - FS (AP)..... 69.00/ea.
PP216 1973-77 Heater Core, w/ AC - GP (AP) 65.00/ea.
PP218 1973-77 Heater Core, w/o AC - GP (AP) 65.00/ea.
PP218P 1961-77 Heater Core Nipple Plugs (RE) 8.00/pr.



PP222

- PP221** 1964-77 Blower Motor, w/o AC - All (AP)..... 34.00/ea.
PP222 1964-77 Blower Motor, w/AC - All (AP) 34.00/ea.



PP222AF

- PP222AF** 1959-77 Blower Motor Wheel - All Exc. AC (RP) \$25.00/ea.



PP222D

- PP222D** 1964-69 Blower Motor Wire Firewall Grommet - All exc. AC (AP) 5.50/ea.



PP222F

- PP222F** 1969-76 Blower Motor and Accessory Wire Firewall Grommet (RE)..... 12.00/ea.

Refer to photo for application. Fits 1969-72 GP AC wire, 1970-76 blower motor w/o AC, and various years rally gauge accessory wires.

- PP228J** 1971-76 Blower Motor Switch - FS exc. ATC (GM) 9.00/ea.

- PP228J** 1973-76 Blower Motor Switch - GP exc. ATC (GM) 9.00/ea.



PP230D

- PP230D** 1964-71 Evaporator Drain Tube (RE)..... 15.00/ea.

This is the black drain tube that attaches to the bottom of the evaporator box. Usually these are missing or destroyed from engine compartment heat.

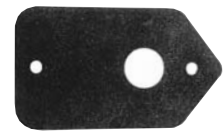

PP232J

- PP232J** 1955-57 Heater Control Valve to Firewall Gasket (RE) Disc.



PP292A

- PP292A** 1966-72 Heater Blower Motor Case - All w/o AC (GM) 42.00/ea.

This case absolutely will not fit a car that has ever had AC.

- PP293J** 1965-68 Heater Box Seal - All w/o AC (RE)..... 20.00/ea.

This piece is actually a continuation of the firewall pad. It mounts on the inside of the car.

HEATER AND AC SEAL KITS



PP294E

- PP294E** 1969-72 Heater Box Seal Kit - GP exc. AC (AP) .. 22.00/kit

- PP294G** 1969-72 Heater and AC Box Seal Kit - GP w/AC (AP) 22.00/kit

These kits include various seals; some are used to replace the caulking used originally by GM.

AUTOMATIC TEMPERATURE CONTROL VACUUM COMPONENTS



		PP235JA	
PP235JA	1965	ATC Servo System Vacuum Canister w/AC (RE)	\$155.00/ea.
PP235JC	1966	ATC Servo System Vacuum Canister w/AC (RE)	51.00/ea.

		PP235JJ	
PP235JJ	1965-66	ATC Servo System Vacuum Line Valve w/AC (GM).....	\$11.00/ea.
PP238	1967-72	Cruise Control Bellows (RE)	20.00/ea.

RADIATOR HOSES & COMPONENTS



		PP259	
PP240	1955-56	Upper Radiator Hose, w/o AC (AP)	\$19.00/ea.
PP241	1957	Upper Radiator Hose, w/o AC (AP)	19.00/ea.
PP242	1957	Upper Radiator Hose, 3-2 bbl, w/o AC (AP)	19.00/ea.
PP245	1955-57	Lower Radiator Hose, w/o AC (AP).....	19.00/ea.
PP242	1958	Upper Radiator Hose, 3-2 bbl - All (AP)	19.00/ea.
PP243	1958	Upper Radiator Hose, w/2 or 4 bbl, w/o AC (AP)	19.00/ea.
PP246	1958	Lower Radiator Hose - All (AP).....	19.00/ea.
PP243	1959-60	Upper Radiator Hose, w/o Air Susp. w/3-2 bbl (AP).....	19.00/ea.
PP248	1959-60	Upper Radiator Hose, w/o Air Susp. w/2 or 4 bbl (AP)	19.00/ea.
PP250	1959-60	Lower Radiator Hose - All (AP).....	Disc.
PP248	1961-62	Upper Radiator Hose, w/2 or 4 bbl(AP)	19.00/ea.
PP249	1961-63	Upper Radiator Hose, w/3-2 bbl or 2-4 bbl (AP)	24.00/ea.
PP243	1961-65	Lower Radiator Hose - All (AP).....	19.00/ea.
PP252	1963	Upper Radiator Hose, w/2 or 4 bbl (AP)	26.00/ea.
PP252	1964	Upper Radiator Hose, w/3-2 bbl (AP) ...	26.00/ea.
PP253	1964	Upper Radiator Hose, w/2 or 4 bbl (AP)	25.00/ea.
PP254	1964	Upper Radiator Hose, w/PS - V8 w/Tri-Power (AP)	25.00/ea.
PP255	1965	Upper Radiator Hose, w/o PS - V8 exc. Tri-Power (AP).....	16.00/ea.
PP254	1965-67	Upper Radiator Hose, w/PS - V8 exc. Tri-Power (AP).....	25.00/ea.
PP256	1966-67	Upper Radiator Hose, w/o PS - V8 exc. Tri-Power (AP).....	22.00/ea.
PP257	1966-68	Lower Radiator Hose - All (AP).....	19.00/ea.
PP254	1968	Upper Radiator Hose - All (AP)	25.00/ea.
PP258	1969-70	Upper Radiator Hose - GP (AP).....	29.00/ea.
PP254	1969-70	Upper Radiator Hose - FS (AP)	25.00/ea.
PP260	1969-70	Lower Radiator Hose - FS (AP)	20.00/ea.
PP261	1971-72	Upper Radiator Hose - GP (AP).....	28.00/ea.
PP259	1969-72	Lower Radiator Hose - GP (AP)	24.00/ea.
PP262	1971-72	Upper Radiator Hose - FS (AP)	28.00/ea.
PP263	1971-72	Lower Radiator Hose - FS (AP)	21.00/ea.
PP258	1973-76	Upper Radiator Hose - GP (AP).....	29.00/ea.
PP259	1973-74	Lower Radiator Hose - GP (AP)	24.00/ea.
PP264	1973-76	Upper Radiator Hose - FS (AP)	26.00/ea.
PP265	1973-76	Lower Radiator Hose - FS (AP)	20.00/ea.
PP268	1975-77	Lower Radiator Hose - GP (AP)	24.00/ea.
PP269	1977	Upper Radiator Hose - All w/301, 305P and 400 (AP)	28.00/ea.

PP277	Original Wire-Type Hose Clamp, 1 1/2" Radiator Hose (AP).....	1.50/ea.
PP278	Original Wire-Type Hose Clamp, 1 3/4" Radiator Hose (AP).....	1.50/ea.
PP279	Original Wire-Type Hose Clamp, 2" Radiator Hose (AP).....	5.00/ea.



		PP280	
PP280	Original Post-Type Hose Clamp for 1 1/2" Radiator Hose (APE)	2.00/ea.	
PP281	Original Post-Type Hose Clamp for 1 3/4" Radiator Hose (APE)	2.00/ea.	
PP282	Original Post-Type Hose Clamp for 5/8" Heater Hose (APE).....	2.00/ea.	
PP283	Original Post-Type Hose Clamp for 3/4" Heater Hose (APE).....	2.00/ea.	
PP284	Original Wire-Type Hose Clamp for 5/8" Heater Hose (AP)75/ea.	
PP285	Original Wire-Type Hose Clamp for 3/4" Heater Hose (AP)75/ea.	

In an effort to find the correct years for these heater hose clamps we used dealer showroom album photos, 60's magazine articles plus the date codes stamped on clamps taken from original cars.

We found no evidence of their use from 1957-64 (use the PP284 & PP285). In '65 most cars used PP284 & PP285, but several late-production cars were equipped with post-type clamps (earliest post-type clamp date found was April '65). 1966 and newer used the post-type.

Installation Note: Excessive tightening can result in the tower rotating. This can be avoided by holding the tower with an adjustable wrench.



		PP270A	
PP270A	1955-58	Lower Radiator Hose Inner Spring (RE).	5.00/ea.
PP270B	1961-77	Lower Radiator Hose Inner Spring (RE).	5.00/ea.

ENGINE COMPARTMENT

HEATER HOSES & COMPONENTS



PP274J

PP274J 1969-70 Heater Hose - Molded from Heater Core to Cyl. Head (Exc. AC) - GP (APE) \$16.00/ea.

Comments: Quality is excellent.

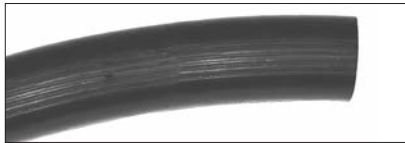

PP274S 1959-74 Correct 5/8" Ribbed Heater Hose (RE)... 4.50/ft.

PP274V 1959-74 Correct 3/4" Ribbed Heater Hose (RE)... 4.50/ft.

For years, all kinds of ribbed heater hose have been sold as correct for 59-74 Pontiacs. In fact, many sources sell hose with ribs sticking out! From salvage yards to original low-mileage cars we've only seen this pattern. It is this five-depressed-rib design.

Comments: Excellent detailing item.



PP287F

PP287F 1964 Heater Hose Bracket, w/o AC 27.00/ea.

PP287F is a stainless steel reproduction. Edges are not rolled like original. Quality is very good.



PP287K

PP287K 1965-77 Heater Hose Bracket, w/o AC - All exc. '71-'75 FS (RE) 24.00/ea.

This bracket mounts on the front of the passenger side head and keeps the heater hose away from the exhaust manifold.



PP287L

PP287L 1963-67 Heater Hose Bracket w/ Screw - All w/ AC (RE)..... 11.00/ea.

This bracket holds the 3/4" heater hose to the passenger side inner fenderwell on AC cars only. Instructions and screw are included. Also used for 1966 all with A.I.R.



PP290E

PP290E 1964 Tri-Power Hose Elbow (RE) Disc.



PP290N

PP290N 1965-71 Heater Hose Nipple - All Pontiac V8 (APE) \$25.00/ea.

This is the nipple that presses into the rear of the passenger side head. This reproduction, like original, has a unique variable spring-type restrictor and knurled nipple.

Quality: Excellent.



PP290NL

PP290NL 1972-77 Heater Hose Nipple - All Pontiac V8 (RE) 25.00/ea.

Like P132N, this nipple presses into the rear of the passenger side head. This is a reproduction of the later design that was previously available from GM that uses a rubber o-ring restrictor unlike the variable restrictor seen on P132N.

Quality: Very Good to Excellent.

FAN SHROUDS & HARDWARE



PP299M

PP299M 1968 Fan Shroud Top Plate, Painted Steel - All (RE) 49.00/ea.

PP299N 1968 Fan Shroud Top Plate, Chrome Steel - All (RE) 65.00/ea.



PP299P

PP299P 1968 Top Plate Bolt Kit, Black Phosphate (RE) 4.00/kit



PP300 & PP301

PP299X 1968 Fan Shroud - Fiberglass - All V8 (RE) 119.00/ea.

Note: This 1968 shroud's exposed surfaces are done well. The back side is rough and will need finish work to be show quality.

PP299Y 1968 Fan Shroud Hardware Kit (RE) 4.50/kit.

PP300 1969-70 Fan Shroud - FS (APE) 185.00/ea.

PP301 1969 Fan Shroud w/3-Core Radiator - GP (APE) 185.00/ea.

PP301A 1969 Fan Shroud w/4-Core Radiator - GP (APE) 185.00/ea.

PP302A 1970 Fan Shroud w/3-Core Radiator - GP (APE) 185.00/ea.

PP302B 1970 Fan Shroud w/4-Core Radiator - GP (APE) 185.00/ea.

PP303 1971-72 Fan Shroud w/3-Core Radiator - GP (APE) 185.00/ea.

PP303A 1971-72 Fan Shroud w/4-Core Radiator - GP (APE) 185.00/ea.

Note: PP301 is just the shroud. It does not include the extension.

Add \$8.00 oversize fee to standard shipping for PP299X

Add \$20.00 oversize fee to standard shipping for PP300-PP303A

Fan shrouds and hardware continues on next page.

Fan shrouds and hardware continued.



PP301B

PP301B 1969-72 Fan Shroud Hardware Kit For PP300 and PP301 (RE)..... \$4.50/kit



PP309

PP310

PP309 1965-66 421 Radiator Shroud Emblem (RE) Disc.
PP310 1967-68 428 Radiator Shroud Emblem (RE) 26.00/ea.

Comments: PP309 and PP310 are a low-pressure casting. Overall quality is good.

FAN COMPONENTS



PP304G

PP304G 1959-76 Fan Clutch - All Pontiac V8 (RP)..... 71.00/ea.
PP304GM 1959-76 Fan Clutch - All Pontiac V8 (GM) Disc.
PP304P 1969-75 5-Blade 19" Flex Fan (RE) 109.00/ea.



PP304P



PP304GL

PP304GL 1959-76 Fan to Fan Clutch Bolt Kit, 4 pc. (RP) 2.50/kit
PP304K Fan Clutch to Water Pump Bolt Kit, 4 pc. (RP)..... 2.50/kit
 Includes 5/16-24 x 3/4" bolts - check your original before ordering.



PP304L

PP304L Fan Clutch to Water Pump Stud Kit (RP) 5.00/kit
 Includes 4 studs, 4 lock washers and 4 nuts. Applications vary. Check your original before ordering.

GROUND STRAPS



PP315

PP315 Ground Straps - Set of 3 (RE) \$18.00/set
 This set includes 2 - 9 1/2" straps and 1 - 6" strap with attaching hardware.

Note: These straps are not exactly like originals but are an excellent replacement.

PP315A Ground Straps - Set of 3 (RE) 17.00/set
 This set includes 1 - 9 1/2" strap, 1 - 6" strap and 1 - 4 3/4" strap with attaching hardware.

Note: Ground straps are used in various locations on full-size Pontiacs. We have found them connecting engine blocks to cowl, inner fenders to frames, and inner fenders to outer fenders.

These straps use the same style braided wire as original and are the final complement for your detailed engine compartment. They are not as heavy gauge as originals.

SEALS AND GASKETS



PP320

PP339 1955 Inner Fender to Outer Fender Seal (RE) . 10.00/set
PP320 1959 Upper A-Frame Seals (RE)..... 19.00/pr.
PP320A 1959 Upper A-Frame Seals w/Staples (RE)..... 21.00/pr.
PP321 1960 Upper A-Frame Seals (RE)..... 19.00/pr.
PP321A 1960 Upper A-Frame Seals w/Staples (RE)..... 21.00/pr.



PP322

PP322 1961 Upper A-Frame Seals (RE)..... 16.00/pr.
PP322A 1961 Upper A-Frame Seals w/Staples (RE)..... 18.00/pr.
PP322B 1961 Splash Seal Kit - 6 Pcs. w/Staples (RE) ... 24.00/set

Note 1: PP322 is included in the PP322B kit.

Note 2: Some late-production 1961 models use the 1962 style A-frame seal. Please refer to the photos of PP322 and PP323 to determine the correct seals for your 1961.

ENGINE COMPARTMENT



PP323

- PP323 1962 Upper A-Frame Seals (RE)..... \$16.00/pr.
- PP323A 1962 Upper A-Frame Seals w/Staples (RE)..... 18.00/pr.
- PP323B 1962 Splash Seal Kit - 6 Pcs. w/Staples (RE) ... 23.00/set

Note: PP323 is included in the PP323B kit.

- PP323J 1962 Radiator Support to Frame Seal (RE) 13.00/pr.
- PP324 1963-64 Upper A-Frame Splash Seal Kit..... 34.00/set
- PP324A 1963-64 Upper A-Frame Splash Seal Kit w/Staples (RE) 36.00/set
- PP325 1965-70 Upper A-Frame Seals - FS (RE)..... 17.00/pr.
- PP325A 1965-70 Upper A-Frame Seals w/Staples - FS (RE) 19.00/pr.
- PP325D 1965-70 Inner Fender to Frame Splash Seals w/Staples - 4 Pcs. - FS (RE)..... 7.50/set
- PP325J 1965 Radiator Support to Frame Seal (RE) 13.00/pr.
- PP325M 1965 Lower Radiator to Frame Seal (RE)..... 19.50/pr.
- PP325P 1965 Upper Radiator to Core Support Seal w/AC (RE) 9.00/ea.



PP328



PP329A

- PP328 1969-71 Upper A-Frame Seals - GP 1st Design (RE) 13.00/pr.
- PP328A 1969-71 Upper A-Frame Seals w/Staples - GP 1st design (RE) 15.00/pr.
- PP329A 1969-71 Upper A-Frame Seals w/Staples - GP 2nd design - 4 Pieces (RE)..... 15.00/set

These seals cover the upper A-frames protecting the engine compartment from water, mud, snow, etc. They are die-cut from .065" masticated rubber like originals. Compare to you originals for correct replacement.

Comments: Very good.

- PP341J 1968-70 Radiator Support to Frame Seals w/Fasteners (RE) 11.00/pr.
- PP346 1959-71 Upper A-Frame Seal Staples, Set of 20 (RE) 3.50/set
- PP347 1959-71 Upper A-Frame Seal Staples, Set of 10 (RE) 2.00/set

These staples are made from .048" high quality galvanized steel. Each set contains enough staples to install a pair of A-frame seals.

AIR CONDITIONING SEAL KIT



PP347J

- PP347J 1961-62 Air Conditioning Seal Kit (RE)..... 30.00/set

This kit is die-stamped from correct masticated rubber. These seals attach between the core support and radiator forcing maximum air through the radiator and shroud for proper cooling. Must reuse original fasteners.

FIREWALL HARNESS GUTTER



PP348K

- PP348K 1965-70 Firewall Wiring Harness Gutter (RE) 7.00/ea.

This gutter mounts on the firewall and holds the engine harness as it passes behind the engine.

BODY PLUGS

- PP360 1/2" Inner Fender Plastic Body Plug (AP) \$.75/ea.

WINDSHIELD WASHER COMPONENTS



- PP365A 1970-72 Windshield Washer Nozzles - GP (APE) 28.00/pr.
- PP365A 1970 Windshield Washer Nozzles - FS (APE) 28.00/pr.



PP374

- PP374 1962-66 Washer Jar - Black (RE)..... 27.00/ea.
- PP375 1962-66 Washer Jar - White (GM)..... 9.00/ea.



PP376

- PP376 1967 Washer fluid Jar, Black w/Black Cap (RP) 30.00/ea.
- This is a replacement washer bottle that mounts differently from the original location. Hole relocation is required.



PP376A

- PP376A 1967 Correct Washer Fluid Jar, Black w/o Cap (APE)..... 42.00/ea.
- PP379E 1969-70 Washer Fluid Jar White w/Black Cap - GP (RE)..... 30.00/ea.
- PP379F 1969-70 Washer Fluid Jar Black w/Black Cap - GP (RE)..... 30.00/ea.

These reproductions come complete with the original center hose connection molded in the cap.

- PP380 1971-72 Washer Jar - GP (GM)..... 23.00/ea.
- PP390 1962-64 Washer Jar Bracket (GM) 10.00/ea.



- PP397 1962-77 Washer Jar Filter (RP) 3.00/ea.
- PP398 1962-74 Washer Jar Cap (GM) 5.00/ea.
- PP398C 1969-70 Washer Jar Cap (Correct style) (GM) 5.00/ea.

ENGINE COMPARTMENT



PP398JC

PP398JC 1961-67 Washer Reservoir Refill Bottle w/ Bracket and Cap (RE) \$35.00/ea.

Note: This is the accessory glass triangular reservoir bottle. It comes complete with stainless steel bracket and printed cap. Nice addition to a detailed engine compartment.



PP398L

PP398K 1960-66 Washer Bottle Cap w/o Lettering (RE) ... Disc.
PP398L 1960-66 Washer Bottle Cap w/Lettering (RE) 5.00/ea.

These are the metal caps used on the triangular glass windshield washer bottles found in the engine compartment of early '60's Pontiacs.



PX355

PX352 1961-63 GM "Kleer-view" Windshield Washer Label (RE) 4.00/ea.
PX355 1964-67 GM Optikleen Windshield Washer Label (RE) 4.00/ea.



PX361

PX361 1964-67 GM "Pontiac Kleer-view" Windshield Washer Label (RE) 4.00/ea.

PX352 through PX361 are non adhesive labels used on refill bottles not reservoirs.

PP399 1/8" Rubber Hose Nozzle to Pump (AP)75/ft.
PP400 1/4" Rubber Hose Washer Bottle to Pump (AP) 1.00/ft.



PP401C

PP401C 1965-66 Windshield Washer Hose Retainer Kit (RE) 23.00/kit

This kit comes complete with the unique "S" shaped hose retainer clips, cowl plate clip bolts and the plastic retainer strap.



PP405

PP405 1963-65 Windshield Washer Pump, Single Speed (RE) \$51.00/ea.

PP407 1968-74 Windshield Washer Pump - All (RE) 55.00/ea.

PP407 will work on original wiper motors only. It will not fit on replacement motors such as PG620 & PG620A.

PP410 1975-77 Windshield Washer Pump w/o Pulse (GM) 72.00/ea.

PP412 1975-77 Windshield Washer Pump w/Pulse (GM) 72.00/ea.

Note: These GM replacements function well but differ physically from original.



PP415

PP415B

PP415 1963-65 & 1968-77 Washer Pump Repair Kit (RP) 9.50/kit

PP415B 1963-65 & 1968-77 Washer Pump Repair Kit (NOS) 19.00/kit

FIREWALL PLUGS & GROMMETS



PP500

PP500 1955-60 Firewall Grommet (RE) 3.00/ea.
 Fits 1/2" hole w/1/8" center hole.

PP502 1955-60 Firewall Grommet (RE) 3.50/ea.
 Fits 3/4" hole w/3/16" center hole.

PP504 1955-56 Firewall Grommet 18.00/ea.
 Fits 1 3/4" x 3" oval hole w/1/2" center hole.

PP506 1956-58 Firewall Grommet 5.00/ea.
 Fits 1 3/8" hole w/9/16" center hole.

PP508 1955-57 Headlight Wire Grommet 6.00/ea.
 To be used with square clip (not included). Fits 7/8" hole w/7/16" center hole.



PP512

PP520

PP512 1957-58 Bonneville Fuel Injection Grommet Kit - 9 Pcs. (RE) 99.00/kit

Kit contains 4 shroud hold-down grommets, 3 shroud hole plugs, 1 three-hole wire grommet and 1 fuel injection drive seal.

PP520 1965-67 Firewall Grommet - Accessory Wiring (RE) 18.00/ea.

TRANSMISSION, CLUTCH, BRAKE

PEDAL PADS & COMPONENTS



PR100

PR100 1955-62 Clutch and Brake Pedal Pads, MT (RE).. \$28.00/pr.
PR101 1963 Clutch and Brake Pedal Pads, MT (APE) 16.50/pr.



PR101



PR130

PR130 1969-72 Accelerator Pedal - GP (APE) \$15.00/ea.
PR131 1971-73 Accelerator Pedal - FS (GM)..... 11.00/ea.
PR131 1973 Accelerator Pedal - GP (GM) 11.00/ea.



PR102

PR102 1964 Clutch and Brake Pedal Pads, MT (APE) 16.50/pr.
Comments: Excellent.



PR103

PR103 1965-70 Clutch and Brake Pedal Pads, MT - FS (APE) 11.00/pr.

PR103 1969-72 Clutch and Brake Pedal Pads, MT - GP (APE)..... 11.00/pr.

These 14-rib pedal pads are exact reproductions of the factory design used from '65 to '70. Excellent.

Other sources sell this part, but have been forced to grind the rubber to accept trim plates. Their pads do not have the same contours as original.

PR115 1965-70 Brake Pedal Pad, AT - FS (APE) 12.00/ea.
Comments: Excellent.

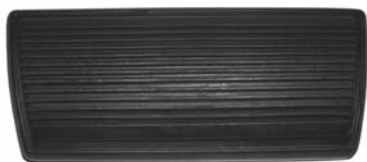

PR117

PR117 1969-72 Brake Pedal Pad, AT - GP (APE)..... 10.00/ea.



PR118

PR118 1971-73 Brake Pedal Pad, AT - FS (RE) 23.00/ea.



PR120

PR119 1973-77 Brake Pedal Pad, AT - GP (GM) Disc.
PR120 1976-77 Brake Pedal Pad, AT exc. Custom Trim GP (GM) 8.50/ea.

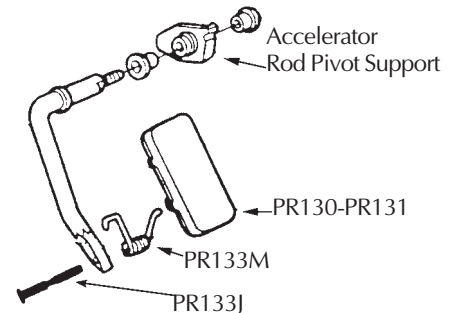

PR133J 1969-73 Accelerator Pedal Pad Pin - GP (GM) ... 3.00/ea.
PR133J 1971-73 Accelerator Pedal Pad Pin - All (GM).... 3.00/ea.
PR133M 1969-73 Accelerator Pedal Pad Spring - GP (GM) 4.00/ea.
PR133M 1971-73 Accelerator Pedal Pad Spring - FS (GM) 4.00/ea.



PR133P

PR133P 1965-70 Accelerator Pedal Pad Pins, Pair - FS (RE) ... 19.00/pr.
 These are the two pins that hold the pad in place to the floor.

PR133R 1970-75 Accelerator Rod Pivot Support - FS (GM) 15.00/ea.
PR133R 1973-77 Accelerator Rod Pivot Support - GP (GM) 15.00/ea.



PR150

PR150 1963-64 Parking Brake Pedal Pad (APE) 9.00/ea.
 This emergency pedal pad has the original pattern with the correct 17 ribs. These ribs fold down the sides of the pad.



PR151

PR151 1965-70 Parking Brake Pedal Pad - All (APE) 8.00/ea.
 This pad has the correct eleven ribs.
PR152 1971-72 Parking Brake Pedal Pad - All (GM) 4.00/ea.
PR152 1976-77 Parking Brake Pedal Pad - All (GM) 4.00/ea.

TRANSMISSION, CLUTCH, BRAKE

PEDAL TRIM PLATES



PR160

- PR160** 1965-70 Clutch and Brake Pad Trim, MT - FS (APE) \$15.00/pr.
PR160 1969-72 Clutch and Brake Pad Trim, MT - GP (APE) 15.00/pr.



PR171

- PR171** 1969-72 Brake Pad Trim, AT - GP (APE) 12.00/ea.
PR173 1973-77 Brake Pad Trim, AT - GP (RE) 11.00/ea.
PR180 1965-70 Parking Brake Trim Plate - All (APE) 11.00/ea.



PR190

- PR190** 1969-72 Accelerator Pedal Trim Plate - GP (APE) 13.00/ea.
PR191 1971-73 Accelerator Pedal Trim Plate - FS (RE) ... 7.00/ea.
PR191 1973 Accelerator Pedal Trim Plate - GP (RE).. 7.00/ea.

The PR160 through PR190 trim plates are some of our finest reproductions. Made from original correct stainless steel, they are stamped well within factory specifications.

Comments: Excellent.

FLOOR SHIFT PORCH



PR230

- PR230** 1969-72 Floor Shift Porch, MT - GP (RE) 39.00/ea.

These are reproduction shift porches. Many porches on original Grand Prix have been altered for different shifters or are missing altogether. Also used for 4-speed conversions.

Comments: Very good—made by the same shop as our high-quality floors, trunks and patch panels.

- PR230CG** 1961-64 4-Speed Shift Porch Cat/GP (AP) 129.00/ea.
PR231 1961-72 Shift Porch Screw Set (RE) 3.00/set

PR231 is used to secure the shift porch to the floor.



PR231

SHIFT BOOTS & SEALS



PR238J

- PR238** 1965-68 Lever Seal (Plastic Strip) w/Console, AT - FS (APE) 12.00/ea.
PR238J 1969-77 Lever Seal (Plastic Strip) w/Console, AT - GP (GM) 8.00/ea.

These seals replace the cracked and broken seals found on most 3-speed automatic consoles.



PR239MA

- PR239M** 1955-56 3-Speed Column Shift Boot, MT (Black) (RE) \$10.00/ea.



PR240

- PR239MA** 1955-56 3-Speed Column Shift Boot, MT (Orange) (RE) 13.00/ea.
PR240 1960-64 Shift Boot, 4-Speed w/Bench Seat (RE).. 35.00/ea.
PR241 1960-63 Shift Boot, 4-Speed w/Bucket Seats w/Reverse Lockout (APE) 15.00/ea.
PR242 1963-64 Shift Boot, 4 Spd. w/Bucket Seats w/o Reverse Lockout (APE) 15.00/ea.
PR244 1965-69 Shift Boot, MT - FS (RE) 20.00/ea.
PR244 1969-72 Shift Boot, MT - GP (RE) 20.00/ea.



PR244C

- PR244C** 1965-69 Shift Boot, MT - FS (GM) 68.00/ea.
PR244C 1969-72 Shift Boot, MT - GP (GM) 68.00/ea.

Note: PR240 through PR244C are the shift boots that attach to the floor. These boots are used whether or not your manual floor shift car is equipped with a console.



PR246

- PR246** 1962-63 Shift Bellows, MT w/Console and w/Reverse Lockout (APE) 22.00/ea.
PR247 1963-64 Shift Bellows, MT w/Console and w/o Reverse Lockout (APE) 22.00/ea.

Note: PR246 and PR247 are the bellows which attach to the console and surround the shift lever. They are exact reproductions using original Seville grain stitched silver vinyl and molded grommets.

SHIFT BOOT TRIM PLATES



PR250

- PR249** 1960-64 Shift Boot Trim Plate, 4 Spd. w/Bench Seat (RE) 9.00/ea.

Note: This fits the PR240 boot.

- PR250** 1960-64 Shift Boot Trim Plate, w/ or w/o Console w/Bucket Seats (APE) 16.00/ea.

Note: This fits the PR241 and PR242 boots.

- PR251** 1960-64 Shift Boot Trim Plate Screws (RE) 1.50/set



- PR255 1965-69 Shift Boot Chrome Trim Plate - FS (APE) \$16.00/ea.
 PR255 1969-72 Shift Boot Chrome Trim Plate - GP (APE) 16.00/ea.
- The PR255 trim plate is an exact reproduction of the original chrome bezel used on all 1965-1972 non-console-shift applications. For console shift plate, use PR255A. PR255 can also be combined with PR244C boot to give a correct factory appearance when converting your car to a 4-speed.
- PR255A 1965-69 Shift Boot Trim Plate, Black - FS (APE) ... 15.00/ea.
 PR255A 1969-72 Shift Boot Trim Plate, Black - GP (APE).. 15.00/ea.
- PR255A is the black trim plate used in console applications.
- PR256 1965-72 Shift Boot Trim Plate Screw Set (RE) 1.50/set

SHIFT KNOBS

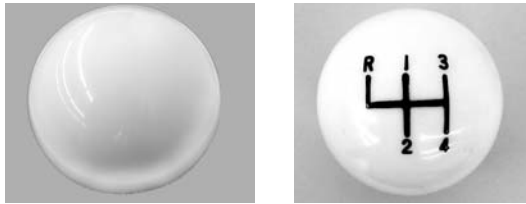

- PR301 1960-64 4-Speed Shift Knob (White w/o Pattern) (RE) 18.00/ea.
 PR302 1960-64 4-Speed Shift Knob (White w/ Pattern) (RE) 20.00/ea.



- PR304 1960-64 4-Speed Shift Knob (White w/Pattern) (AP) 18.00/ea.

Many customers have requested a white four-speed knob with the same dimensions as our PR305. Use where originality is not required—thread is 3/8"-16.

- PR305 1965-68 4-Speed Shift Knob (Black w/Pattern) (RE) 18.00/ea.
 PR305 1969-70 4-Speed Shift Knob (Black w/Pattern) -GP (RE) 18.00/ea.

This knob is slightly smaller in diameter than the original 1969-70 Grand Prix. Fit and appearance are good.

- PR305B 1969-70 4-Speed PMD Walnut Shift Knob (RE) .. 49.00/ea.
 PR305C 1969-70 4-Speed Walnut Shift Knob (RE) 49.00/ea.
 PR305D 1971 4-Speed Walnut Shift Knob (RE) 49.00/ea.
 PR305F 1969-70 4-Speed Walnut Shift Knob (RE) 39.00/ea.
 PR307 1969-74 Large 4-Speed Shift Knob (Black w/Pattern) -GP (RE) 28.00/ea.

This is a reproduction of the large 4-Speed knob; however, it is 1/8" larger in diameter than original.

- PR309 1965-73 3-Speed Shift Knob (Black w/Pattern) -All (RE) \$28.00/ea.

This knob is a bit larger than original and comes with an insert for 3/8" threads.



- PR319 1962-64 Shift Ball, All AT w/Console (RE) 25.00/ea.
 PR319A 1962-68 Shift Button, All AT w/Console (RE) 12.50/ea.

PR319 & PR319A are reproduced in polished stainless steel and quality is excellent. For 1968 applications, PR319A is used only where a shift ball is used.

- PR319B 1971-72 Walnut Shift Knob, AT (RE) 49.00/ea.



- PR320 1968 Automatic Outer Handle w/Console "T" Shifter (RE) 16.00/ea.

This plastic reproduction will rejuvenate those original T-handles that are often broken and useless (comes w/retainer).

- PR330 Hurst Brushed Aluminum T-Handle w/Checknut - All Hurst Shifters (AP) 28.00/ea.

Note: Thread is 3/8"-16.

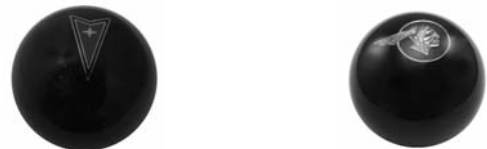

- PR331TA Pontiac Arrowhead Logo Shift Knob (AP) 25.00/ea.
 PR331TB Indian Head Logo Shift Knob (AP) 25.00/ea.

BACK-UP LIGHT SWITCHES

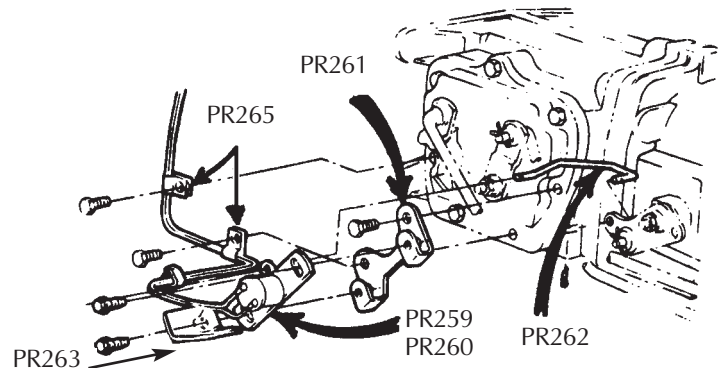

- PR259 1960-64 Back-Up Light Switch, 4 Spd. (RP) 59.00/ea.
 Except in certain applications where the wiring harness may differ, this switch is the same as original.
- PR260 1965-67 Back-Up Light Switch, 4 Spd. (RP) 59.00/ea.
 This switch is an exact replacement for 1965-67 models.
- PR261 1965-67 Back-Up Light Switch Bracket, MT (RE) 12.00/ea.
 PR262 1965-67 Back-Up Light Switch Rod, 4 Spd. (RE). 5.00/ea.

TRANS, CLUTCH, BRAKE



PR263

PR263 1960-67 Back-Up Light Switch Shield (RE) \$10.00/ea.
This often-missing shield protects the switch from road debris.



PR264

PR264 1968 Back-Up Light Switch, MT (GM) 28.00/ea.
PR264 fits the original 1968 shifter only.



PR264B

PR264B 1969-73 Back-up Light Switch - All (RE) 30.00/ea.

PR265 1964-68 Back-Up Light Wire Clips (RE) 4.50/pr.

PR267 1961-72 Back-Up Light Switch, 4 Spd. w/Hurst Linkage (RP) 29.00/ea.

Note: This after-market design is not the same as original. It uses a plunger switch that contacts the reverse arm activating the back-up lights. This is a less expensive alternative to PR259 or PR260.

TRANSMISSION SHIFT CABLES & COMPONENTS

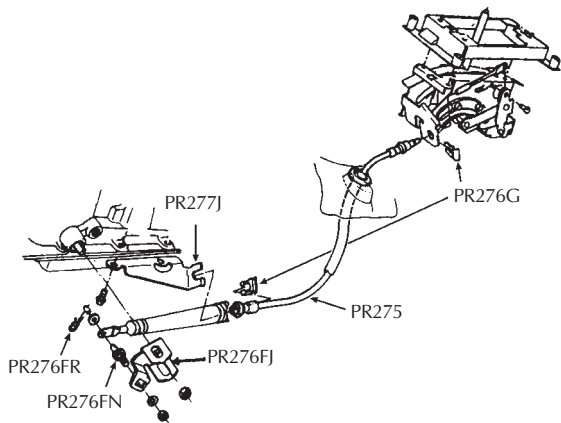

PR275 1965-68 Transmission Shift Cable, AT w/Console - FS (RE) 45.00/ea.

PR276 1969-72 Transmission Shift Cable, AT w/Console - GP (GM) 65.00/ea.

PR276B 1973-77 Transmission Shift Cable, AT M40 w/Console - GP (RP) 43.00/ea.



PR276FJ

PR276FJ 1969-77 Shift Cable Lever, AT w/Console - GP (GM) 22.00/ea.

PR276FN 1965-77 Shift Cable Lever Pin, AT w/Console - All (GM) 7.50/ea.

PR276FM 1965-77 Shift Cable Lever Pin, AT w/Console - All (RE) 5.00/ea.

PR276FR 1965-77 Shift Cable to Lever Pin Spring Retainer, AT w/Console (GM) 1.00/ea.

PR276G 1965-74 Shift Cable Mounting Clip, AT w/Console (RE) 1.50/ea.

This clip is used to secure the shift cable to the shifter assembly.



PR276FR

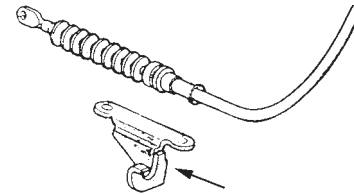

PR277J

PR277J 1969-77 Auto Transmission Shift Cable Bracket, Transmission Mounted M40 w/Console - GP (APE) \$21.00/ea.

PR277K 1969-77 Auto Transmission Shift Cable Bracket, Transmission Mounted M38 w/Console - GP (GM) 7.50/ea.

TRANSMISSION COOLING LINES

These lines are considered the best in the industry. Stainless steel lines are made from high-quality 304 stainless. Transmission cooling lines are drop-shipped directly from our manufacturer and must be prepaid.

Note: Beware of low-quality reproductions of these transmission lines at discounted prices.

Add \$24.00 oversize fee to standard shipping for cooling lines.

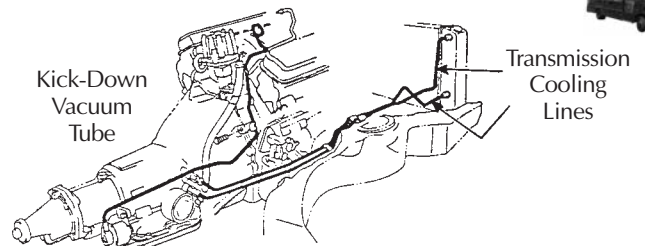

PR287C 1955-57 Transmission Cooling Lines - Bonneville & Starchief - Steel (RE) 47.00/pr.

PR287CA 1955-57 Transmission Cooling Lines - Bonneville & Starchief - Stainless Steel (RE) 78.00/pr.

PR287D 1958 Transmission Cooling Lines - Bonneville & Starchief - Steel (RE) Inquire

PR287DA 1958 Transmission Cooling Lines - Bonneville & Starchief - Stainless Steel (RE) Inquire

PR287JA 1959-60 Transmission Cooling Lines - Bonneville - Steel (RE) 47.00/pr.

PR287JB 1969-60 Transmission Cooling Lines - Bonneville - Stainless Steel (RE) 78.00/pr.

PR287JJ 1961-62 Transmission Cooling Lines - Catalina/GP - Steel (RE) 47.00/pr.

PR287JK 1961-62 Transmission Cooling Lines - Catalina/GP - Stainless Steel (RE) 78.00/pr.

PR287JN 1961-62 Transmission Cooling Lines - Bonneville - Steel (RE) Inquire

PR287JO 1961-62 Transmission Cooling Lines - Bonneville - Stainless Steel (RE) Inquire

PR287K 1963-64 Transmission Cooling Lines - Bonneville & Starchief - Steel (RE) 47.00/pr.

PR287KA 1963-64 Transmission Cooling Lines - Bonneville & Starchief - Stainless Steel (RE) 78.00/pr.

PR287KC 1963-64 Transmission Cooling Lines - All exc. Bonneville & Starchief - Steel (RE) 47.00/pr.

PR287KD 1963-64 Transmission Cooling Lines, All exc. Bonneville & Starchief-Stainless Steel (RE) 78.00/pr.

PR287L 1965-66 Transmission Cooling Lines -All - Steel (RE) 47.00/pr.

PR287LA 1965-66 Transmission Cooling Lines - All, Stainless Steel (RE) 78.00/pr.

PR287LC 1967-68 Transmission Cooling Lines- All- Steel (RE) 47.00/pr.

PR287LD 1967-68 Transmission Cooling Lines - All- Stainless Steel (RE) 78.00/pr.

PR287RA 1969-70 TH350 - 400 Transmission Cooling Lines - FS w/ AC- Steel (RE) 47.00/pr.

TRANS, CLUTCH, BRAKE

PR287RB	1969-70 TH350 - 400 Transmission Cooling Lines - FS w/ AC- Stainless Steel (RE)	\$78.00/pr.
PR287RE	1969-70 TH350 - 400 Transmission Cooling Lines - FS w/o AC- Steel (RE)....	47.00/pr.
PR287RF	1969-70 TH350 - 400 Transmission Cooling Lines - FS w/o AC - Stainless Steel(RE)	78.00/pr.
PR287RJ	1971-75 TH400 Transmission Cooling Lines - FS- Steel (RE)	47.00/pr.
PR287RK	1971-75 TH400 Transmission Cooling Lines - FS- Stainless Steel (RE)	78.00/pr.
PR287RN	1969-72 TH350 Transmission Cooling Lines - GP- Steel (RE)	47.00/pr.
PR287RO	1969-72 TH350 Transmission Cooling Lines - GP- Stainless Steel (RE).....	78.00/pr.
PR287RS	1969-72 TH400 Transmission Cooling Lines - GP- Steel (RE)	47.00/pr.
PR287RT	1969-72 TH400 Transmission Cooling Lines - GP- Stainless Steel (RE).....	78.00/pr.
PR287S	1973-77 TH400 Transmission Cooling Lines - GP- Steel (RE)	Inquire
PR287SA	1973-77 TH400 Transmission Cooling Lines - GP- Stainless Steel (RE).....	Inquire



PR287TW Transmission Cooler Line Clamp (RE) ... 8.00/ea.
 PR287TW bolts to the passenger's side frame rail to support the cooler lines. Insulators not available. Fits various applications; compare to original.

VACUUM MODULATOR & LINES

Add \$10.00 oversize fee to standard shipping for modulator lines.



PR287VL	1965-77 Vacuum Modulator Valve, AT (RE)	29.00/ea.
PR288F	1965 Vacuum Modulator Line -FS- 2bbl (TH400) (RE)	Inquire
PR288FA	1965 Vacuum Modulator Line - FS- 4bbl (TH400) (RE)	Inquire
PR288FC	1966 Vacuum Modulator Line - FS - 2bbl (TH400) (RE)	26.00/ea.
PR288FD	1966 Vacuum Modulator Line - FS - 4bbl (TH400) (RE)	26.00/ea.
PR288FE	1967 Vacuum Modulator Line - FS - 2bbl (TH400) (RE).....	26.00/ea.
PR288FF	1967 Vacuum Modulator Line - FS - 4bbl (TH400) (RE).....	26.00/ea.
PR288FG	1968 Vacuum Modulator Line - FS - 2bbl (TH400) (RE).....	26.00/ea.
PR288FH	1968 Vacuum Modulator Line - FS - 4bbl (TH400) (RE).....	26.00/ea.
PR288JA	1969-70 Vacuum Modulator Line - FS - 2bbl (TH400) (RE).....	26.00/ea.
PR288JD	1969-70 Vacuum Modulator Line - FS - 4bbl (TH400) (RE).....	26.00/ea.
PR288JF	1971 Vacuum Modulator Line - FS - 4bbl (TH400) (RE).....	26.00/ea.
PR288JJ	1969-72 Vacuum Modulator Lines - GP - 2bbl (TH400) (RE).....	26.00/ea.
PR288JN	1969 Vacuum Modulator Lines - GP - 4bbl (TH400) (RE).....	26.00/ea.
PR288JR	1970-72 Vacuum Modulator Lines - GP - 4bbl (TH400) (RE).....	26.00/ea.
PR288JV	1973-77 Vacuum Modulator Lines - GP - 4bbl (TH400) (RE).....	Disc.

All vacuum modulator lines are made from steel.

OEM TRANSMISSION FILTER KITS

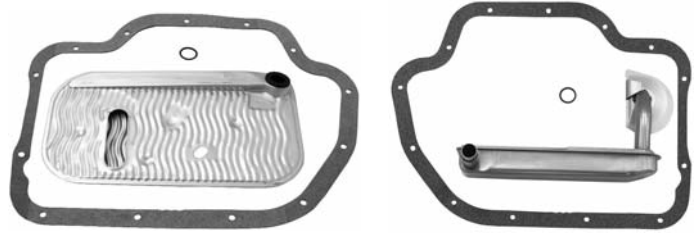

PR289PC

PR289PR

PR289PB	1969-77 Transmission Filter Kit - All V8 w/TH350 (GM)	\$12.00/kit
PR289PC	1967-74 Transmission Filter Kit - All V8 w/TH400 (GM)	12.00/kit
PR289PR	1965-Early 67 Transmission Filter Kit - All V8 w/TH400 (RE)	35.00/ea.

TRANSMISSION PANS & BOLTS



PR289PF	1969-77 Transmission Oil Pan - TH350 (GM)	43.00/ea.
PR289PG	1967-74 Transmission Oil Pan - TH400 Second Design (GM).....	85.00/ea.

Note: Second design pan has only two dimples; the first design has three.

PR289QB	1965-74 Transmission Oil Pan Bolt Kit - TH400 (RP)	6.00/kit
PR289QC	1969-77 Transmission Oil Pan Bolt Kit - TH350 (RP)	6.00/kit

AUTOMATIC TRANSMISSION DIPSTICKS, TUBES & SEALS



PR289RJ

PR289RJ	1968-73 Transmission Dipstick, AT - TH350, All (GM-RP).....	12.00/ea.
PR289RJ	1970-73 Transmission Dipstick, AT - TH400, GP (GM-RP)	12.00/ea.
PR289RJ	1971-73 Transmission Dipstick, AT - TH400, FS (GM-RP).....	12.00/ea.
PR289RL	1974-77 Transmission Dipstick, AT -All (GM-RP)	12.00/ea.
PR289SL	1974-77 Transmission Dipstick Tube, AT - All (GM-RP)	Disc.
PR289SX	1965-77 Transmission Dipstick Tube Seal, AT (GM-RP)	2.50/ea.

PR289SX seals the dipstick tube to the transmission case.



PR289TB

PR289TB	Universal TH400 Dipstick, Tube and Seal (AP)....	49.00/ea.
----------------	--	-----------

This universal dipstick and tube must be used together to provide an accurate fluid level reading.

TRANS, CLUTCH, BRAKE



- PR289VF** 1965-74 Tailshaft Output Seal -TH400 (RP)..... \$10.00/ea.
PR289VJ 1969-77 Tailshaft Output Seal -TH350(RP)..... 5.00/ea.

UNIVERSAL SPEEDOMETER CABLES

- PR294** 1955-69 Speedometer Cable w/Casing, Universal - All (RP) Inquire

PR294 is a universal cable with a steel casing which was common on early applications. It is 70" long with a screw-on fitting on the speedometer head end.

- PR295** 1955-72 Speedometer Cable w/o Casing, Universal - All (GM) \$29.00/ea.

This universal cable is 70" long. Instructions are included for cutting and installation.

SPEEDOMETER CABLE GROMMET



PR295J

- PR295D** 1955-58 Speedometer Cable Grommet (RE)..... 4.00/ea.
PR295J Speedometer Cable Grommet (RE)..... 5.50/ea.

This grommet fits into 1 1/2" firewall hole.



PR295P

- PR295P** 1963-75 Speedometer Gear Housing, All MT (GM) 15.00/ea.
PR297C 1969-72 Speedometer Gear Housing, All Muncie MT (GM) 15.00/ea.

COLUMN SHIFT COMPONENTS



PR332H

- PR332DA** 1968-77 Column Shift Lever Knob - All AT (GM) Disc.
PR332H 1969-77 GP & 71-75 FS Column Shift Pivot Bushing - AT (GM).. 2.50/ea.
PR332K 1967-77 Column Shift Control Rod to Shift Level Swivel - All AT (GM) 10.50/ea.

SHIFTER PLATE



PR345

- PR345** 1969-72 Shifter Plate w/Nut - GP (APE) 25.00/ea.

These are aluminum reproductions of the GM shifter plate that adapts the factory Hurst 4-speed shifter to your Muncie transmission.

Comments: Good. Some grinding may be required for proper fit.

- PR345AD** 1964-69 Muncie Shift Mount Nut (RE) 8.00/ea.
PR348 1964-72 Hurst Shifter Dust Cover (RE) 9.00/ea.

SPEEDOMETER CABLES WITH CASINGS				
YEAR	3SP	4SP	TH350	TH400
55-56	PR290H	----	----	----
57	PR290E	----	----	----
58-59	N/A	----	----	----
60-62	N/A	PR290D	----	----
63-64	N/A	----	----	----
65-66	PR290J	PR290E	----	N/A
67-68	PR290C	N/A	----	PR290C
69 GP	PR290G	PR290F *1 PR290K *2 PR290L *3	PR290A	PR290F
69 FS	----	----	PR290A	PR290A
70 GP	PR290B	PR290K *2 PR290L *3	PR290A	PR290F
70 FS	----	----	PR290A	PR290A
71 GP	PR290B	PR290M	----	PR290F
71-72 FS	----	----	PR290A	PR290A
72-75 GP	----	----	----	PR290F
73-75 FS	----	----	----	PR290K *4
73-76	----	----	----	PR290J *5
73-76 FS	----	----	----	PR290A
76-77 GP	----	----	----	PR290D

- = NOT APPLICABLE
 N/A = NOT AVAILABLE
 *1 = FIRST DESIGN (ONE PIECE)
 *2 = SECOND DESIGN (TWO PC. UPPER)
 *3 = SECOND DESIGN (TWO PC. LOWER)
 *4 = W/CRUISE CONTROL (UPPER)
 *5 = W/CRUISE CONTROL (LOWER)

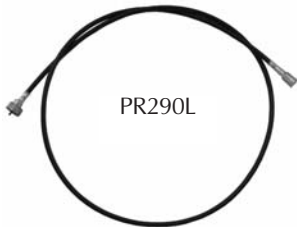

PR290L

- PPR290A** Speedometer Cable (GM)..... Inquire
PR290B Speedometer Cable -76 1/2" (GM) 44.00/ea.
PR290C Speedometer Cable - 57" (GM) 52.00/ea.
PR290D Speedometer Cable - 57" (GM) 52.00/ea.
PR290E Speedometer Cable - 79" (GM) 59.00/ea.
PR290F Speedometer Cable (GM)..... Inquire
PR290G Speedometer Cable (GM)..... 44.00/ea.
PR290H Speedometer Cable - 73" (GM) 55.00/ea.
PR290J Speedometer Cable - 65" (GM) 39.00/ea.
PR290K Speedometer Cable - 45" (GM) 52.00/ea.
PR290L Speedometer Cable - 69" (GM) 39.00/ea.
PR290M Speedometer Cable - 76 1/2" (GM)..... 44.00/ea.

TRANS, CLUTCH, BRAKE

LINKAGE KITS & COMPONENTS



PR420

PR420 1964-66 Hurst Pit Pack (AP) \$11.00/set

Each kit contains enough shift rod bushings and spring clips to refurbish sloppy linkage.

Note: Some year shift linkages did not use bushings; PR420 cannot be used on these shifters.

PR420G 1964-77 Manual Transmission Shifter Rod Clip (RP) \$1.50/ea.
PR420G are the same clips used in the Pit Pack pictured above.



PR421B

PR421B 1967-72 OEM Hurst MT Shifter Lever Retainer (RP) 5.50/ea.



PR421C

PR421C 1967-72 OEM Hurst Shifter Lever Insulator (RP) 12.00/ea.



PR421M

PR421M 1969-72 Hurst Shifter Linkage Kit
4SPD. GP Only (RP) 179.00/ea.



PR421MC

PR421MC 1969 OEM Type Shifter Linkage Kit
4SPD. GP Only (RP) 229.00/ea.

PR421N 1970-72 OEM Type Shifter Linkage Kit
4SPD. GP Only (RE) 229.00/ea.

PR421P 1969-72 Trans. Linkage Lever Set, 3PC
4SPD. GP Only (RE) 39.00/ea.

BACKLOCK COMPONENTS



PR228S

PR228M 1969-72 Back Lock Equalizer Shaft Pivot
Bushing - GP (GM) 3.00/ea.

PR228N 1969-72 Back Lock Tension Spring - GP (RE) 4.00/ea.

PR228P 1969-72 Back Lock Rod to Lever Swivel
- GP (GM) 10.00/ea.

PR228S 1969-72 Reverse Lock-Out Rod w/ Swivel,
4 Spd. - GP (RE) 79.00/ea.

PR228R 1969-72 Backlock Hardware Kit - GP (RE) 8.00/ea.

PR228SA 1969-72 Back Lock Dust Shield -GP (RE) 13.00/ea.

HURST SHIFTER REBUILD SERVICE

Hurst Performance can refurbish your Hurst OEM or after-market shifter and make it function like new again. All worn parts are replaced to allow smooth positive shifts. This complete factory rebuild service is available directly from Hurst Performance. For more information contact:



Hurst Performance
Shifter Rebuild Service
9142 Independence Avenue
Chatsworth, CA 91311
Tech Support (818)483-1366
Fax (818)882-6694
www.hurst-shifters.com

Note: Please do not send shifters to Ames Performance Engineering.

TRANSMISSION REBUILD KITS



PR340L

PR340H 1961-64 Borg Warner T10, 4-Speed Rebuild
Kit (AP) \$149.00/kit

PR340J 1963-65 Muncie 4-Speed Rebuild Kit (AP) 189.00/kit

PR340L 1966-74 Muncie 4-Speed Rebuild Kit (AP) 195.00/kit

All rebuild kits come complete with synchro rings, bearings, countershaft, strut keys, springs, gaskets, seals and all necessary small parts (i.e. needle bearings, snap rings, and thrust washers). Each kit carries a one-year warranty.

Identification Note: T10 4-speeds have 9 side cover bolts and Muncie 4-speeds have 7.



PR340M

PR340M 1963-74 Muncie 4-Speed Gasket Set (AP) 24.00/set

PR340MD 1963-70 Tailshaft Seal - All Muncie MT (RP) 5.00/ea.

PR340MG 1971-74 Tailshaft Seal - All Muncie MT (RP) 11.00/ea.

PR340MR Magnetic Transmission Plug, MT (AP) .. 10.00/ea.



PR340MR



PR340ML

PR340ML 1961-77 Transmission Gear Oil, All MT
(23 oz.) (GM) 15.00/ea.

1963-74 Muncie 4spd. refill requires 40oz

MUNCIE TRANSMISSION COMPONENTS

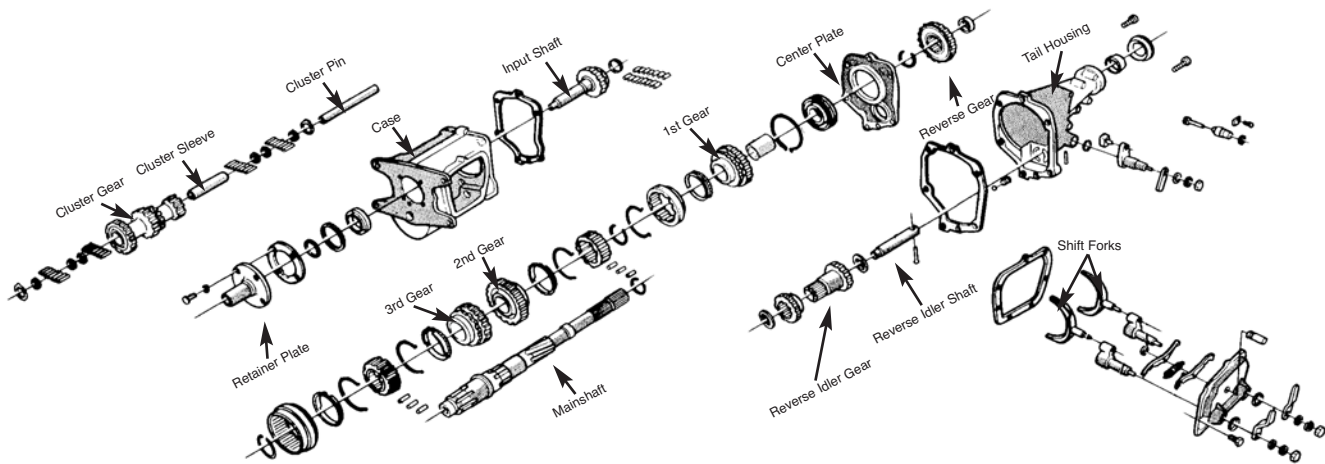

CASE

- PR340NA** 1963-65 Super Case w/7/8" Cluster Pin dia. (RP) . \$389.00/ea.
- PR340NB** 1966-74 Super Case w/1" Cluster Pin dia. (RP)..... 389.00/ea.

The Super Case is a direct replacement to original with the following upgrades; Heavily reinforced mounting ears, .165" thicker front bearing, cluster-shaft front plug (prevents seepage), and new alloy-aluminum construction.

Note 1: Front bearing and plugs are included.
 Note 2: Cases do not have OEM markings.

CENTER PLATE

- PR340ND** 1963-74 Center Plate, All (RP)..... 95.00/ea.

TAILSHAFT HOUSING AND RELATED

- PR340NF** 1969-70 Tailshaft Housing, All w/27 Spline
Mainshaft - GP Only (RE) 269.00/ea.
- PR340NH** 1971-74 Tailshaft Housing, All w/32 Spline
Mainshaft - GP Only (RE) 279.00/ea.

Note: Tailshaft housings do not have OEM markings.

- PR340NK** 1963-70 Tailshaft Bushing, All w/27 Spline
Mainshaft (RE)..... 4.00/ea.
- PR340NM** 1971-74 Tailshaft Bushing, All w/32 Spline
Mainshaft (RE)..... 8.00/ea.
- PR340NP** 1963-70 Tailshaft Rear Seal, All w/27 Spline
Mainshaft (RE)..... 5.00/ea.
- PR340NS** 1971-74 Tailshaft Rear Seal, All w/32 Spline
Mainshaft (RE)..... 7.50/ea.

CLUSTER GEAR AND RELATED

- PR340PA** 1963-65 Cluster Gear, All M20 w/7/8" Pin dia. (RE) 269.00/ea.
- PR340PC** 1963-65 Cluster Gear, All M21 w/7/8" Pin dia. (RE) 269.00/ea.
- PR340PF** 1966-74 Cluster Gear, All M20 w/1" Pin dia. (RE) 269.00/ea.
- PR340PH** 1966-74 Cluster Gear, All M21 w/1" Pin dia. (RE) 269.00/ea.
- PR340PJ** 1971-74 Cluster Gear, All M22 (RE)..... 269.00/ea.

Note: Before ordering cluster gears, be sure to check your cluster gear pin diameter. With transmission swaps being common, the pin diameter may not match the year car you're ordering for.

- PR340PL** 1963-65 Cluster Pin, 7/8" (RE)..... 49.00/ea.
- PR340PN** 1966-74 Cluster Pin, 1" (RE)..... 49.00/ea.
- PR340PP** 1963-65 Cluster Pin Spacer Tube (RE)..... Inquire
- PR340PR** 1966-74 Cluster Pin Spacer Tube (RE)..... 9.00/ea.

FIRST GEAR COMPONENTS

- PR340PT** 1963-74 First Gear - All Exc. M22 (RE)..... 125.00/ea.
- PR340RA** 1971-74 First Gear - M22 (RE)..... 169.00/ea.
- PR340RC** 1963-74 First Gear Bushing - All (RE) 45.00/ea.

SECOND GEAR COMPONENTS

- PR340RF** 1963-74 Second Gear, All Exc. M22 (RE)..... \$119.00/ea.
- PR340RH** 1971-74 Second Gear, M22 (RE) 159.00/ea.

THIRD GEAR COMPONENTS

- PR340SA** 1963-74 Third Gear, All Exc. M22 (RE)..... 115.00/ea.
- PR340SC** 1971-74 Third Gear, M22 (RE) 139.00/ea.

INPUT SHAFT AND RELATED

- PR340SF** 1963-65 Input Shaft, All M20 (RE)..... 225.00/ea.
- PR340SJ** 1963-70 Input Shaft, All M21 (RE)..... 225.00/ea.
- PR340SM** 1966-70 Input Shaft, All M20 (RE)..... 225.00/ea.
- PR340SP** 1971-74 Input Shaft, All M20 (RE)..... 225.00/ea.
- PR340SS** 1971-74 Input Shaft, All M21 (RE)..... 225.00/ea.
- PR340SV** 1971-74 Input Shaft, All M22 (RE)..... 245.00/ea.
- PR340SZ** 1963-74 Input Shaft Bearing Nut, All (RE) 8.50/ea.
- PR340TA** 1963-74 Input Bearing Retainer Plate, All (RE)..... 36.00/ea.

Note: Fourth gear is incorporated with the input shaft.

REVERSE GEAR COMPONENTS

- PR340TC** 1963-74 Reverse Gear, All (RE)..... 85.00/ea.
- PR340TG** 1963-74 Reverse Idler Gear, Rear, All (RE)..... 115.00/ea.
- PR340TK** 1963-74 Reverse Idler Gear, Front, All
Exc. M22 (RE) 55.00/ea.
- PR340TN** 1971-74 Reverse Idler Gear, Front, M22 (RE)..... 78.00/ea.
- PR340TR** 1963-74 Reverse Idler Shaft, All (RE)..... 28.00/ea.

SYNCHRONIZER ASSEMBLIES

- PR340TV** 1963-65 First-Second Gear Synchronizer
Assembly, All (RE) 129.00/asm.
- PR341AA** 1966-74 First-Second Gear Synchronizer
Assembly, All (RE)..... 129.00/asm.
- PR341AC** 1963-65 Third-Fourth Gear Synchronizer
Assembly, All (RE)..... 129.00/asm.
- PR341AF** 1966-74 Third-Fourth Gear Synchronizer
Assembly, All (RE)..... 129.00/asm.

MAINSHAFTS

- PR341AK** 1969-70 Mainshaft, All 27 Spline - GP Only (RE) 235.00/ea.
- PR341AP** 1971-74 Mainshaft, All 32 Spline - GP Only (RE). 245.00/ea.

SHIFTER FORKS AND SEALS

- PR341AT** 1963-74 Shifter Fork, All (RE) 40.00/ea.
- PR341AW** 1963-74 Shifter Fork Seal, All (RE)..... 2.00/ea.

Not all Muncie transmission components are in stock and may be drop-shipped directly from the manufacturer.

TRANNS, CLUTCH, BRAKE

FLYWHEEL & FLEXPATES



PR428HD

- PR428HC** 1965-75 MT Heavy Duty Steel Flywheel - All Pontiac V8 (RP) \$199.00/ea.
- PR428HD** 1965-75 MT Heavy Duty "Hayes" Steel Flywheel - All Pontiac V8 (AP) 379.00/ea.

PR428HC-PR428HD is a 30lb. flywheel strongly recommended for high performance applications. They will accept 10" or 11" clutch plates. You must use the PR429HJ bolt set with these flywheels.

Add \$12.00 oversize fee to standard shipping for flywheels.



PR428HF

- PR428HDD** 1967-75 Heavy Duty Flexplate, All V8 w/ Hydramatic Transmission (RP) 69.00/ea.
- PR428HF** 1967-75 Automatic Flex Plate, All V8 w/ Hydramatic Transmission (RP) 59.00/ea.
- PR428HG** 1965-77 Flexplate to Crank Heavy Duty Bolt Kit, All AT Pontiac V8 (RP)..... 16.00/kit
- PR428HH** 1965-77 Torque Converter to Flexplate Bolt Kit (RP) 3.00/kit



PR429HJ

- PR429HJ** 1964-77 Flywheel to Crank Shaft Bolt Kit - All MT Pontiac V8 (RP) 13.50/kit



PR390GD

- PR390GD** 1964-77 Pressure Plate to Flywheel Bolt Kit - All MT Pontiac V8 (RP) 3.50/kit

**TAKE A
Kid Car
TO A Show**

www.TakeAKidToACarShow.com

OEM CLUTCH KITS & COMPONENTS

These new clutch kits come complete with clutch disc, pressure plate, throwout bearing, and alignment tool. Pilot bearing is sold separately. See PR390BB and PR390BC. Although kits include a throwout bearing, it is recommended you order PR390BA for 1965-77 cars as it is a much better quality bearing.

Before ordering please check original clutch and confirm disc size and spline count to application listing above. Beware of low-cost low-quality kits on the market.

Add \$10.00 oversize fee to standard shipping for clutch kits.



PR390AC

- PR390AA** 1961-63 Clutch Kit, 421 - 389, 3/4 spd w/ 10 spline -10 1/2" Disc (AP) \$223.00/kit
- PR390AC** 1964 Clutch Kit, 421 - 389, 3/4 spd w/ 10 spline -10 3/8" Disc (AP) 186.00/kit
- PR390AE** 1965-66 Clutch Kit, 421 - 389, 3/4 spd w/ 10 spline -11" Disc (AP)..... 189.00/kit
- PR390AG** 1967-69 Clutch Kit, 400, 3/4 spd w/ 10 spline -10 3/8" Disc (AP) Disc.
- PR390AE** 1967-70 Clutch Kit, 400, HD, w/ 10 spline - 11" Disc (AP)..... 189.00/kit
- PR390AJ** 1970-72 Clutch Kit, 400, 3 spd. w/ 10 spline - 10 3/8" Disc (AP) 185.00/kit
- PR390AL** 1971-72 Clutch Kit, 400, 4 spd. w/ 26 spline - 10 1/2" Disc (AP) 179.00/kit
- PR390AE** 1969 Clutch Kit, 428, 4 spd. w/ 10 spline - 11" Disc (AP)..... 189.00/kit
- PR390AE** 1970-74 Clutch Kit, 455, 3 spd. w/ 10 spline - 11" Disc (AP)..... 189.00/kit
- PR390AN** 1970-72 Clutch Kit, 455, 4 spd. w/ 26 spline - 11" Disc (AP)..... 179.00/kit



PR390BA



PR390BB

- PR390BA** 1965-77 Throwout Bearing (RP) 35.00/ea.
- PR390BB** 1957-77 Pilot Bearing, Ball Bearing Type (RP) 27.00/ea.
- PR390BC** 1957-77 Pilot Bushing, Bronze (RP) 5.00/ea.



PR390BJ

- PR390BJ** Clutch Alignment Tool - 10-spline (AP) 4.50/ea.
- PR390BL** Clutch Alignment Tool - 26-spline (AP) 4.50/ea.

TRANS, CLUTCH, BRAKE

BELL HOUSING & COMPONENTS



PR430

- PR430** 1965-77 Flywheel Cover, MT - All (GM) \$34.00/ea.
PR435 1965-77 Automatic Transmission Converter Cover - All (GM)..... 39.00/ea.

Note: PR435 is a plastic replacement for the original steel cover.



PR435JP



PR435JR

- PR435JP** 1965-77 Flywheel Cover to Bell Housing Hardware Kit, MT - All Pontiac V8(RE) . 3.00/kit
PR435JR 1965-77 Converter Cover to Trans Hardware Kit, AT -All Pontiac V8 (RE) 3.00/kit



PR425

- PR425** 1965-77 Aluminum Bell Housing (RE) 189.00/ea.

Note: The hole for the clutch fork boot may need to be opened slightly with a dremel tool.

Quality: Very Good.

Add \$5.00 oversize fee to standard shipping for PR425



PR360

- PR360** 1965-77 Transmission Bell Housing Plastic Plug Kit (RE) 4.00/kit



PR390GL

- PR390GH** 1964-77 Bell Housing to Engine Block Bolt Kit - All MT Pontiac V8 (RP) 6.50/kit
PR390GL 1964-77 Transmission to Bell Housing Bolt Kit - All MT Pontiac V8 (RP) 4.00/kit
PR390GR 1964-77 Automatic Transmission to Engine Block Bolt Kit - All AT Pontiac V8 (RP)... 6.50/kit

Note: PR390GD - PR390GR are replacement bolt kits that will not have the same bolt markings as original

CLUTCH PEDAL & LINKAGE COMPONENTS

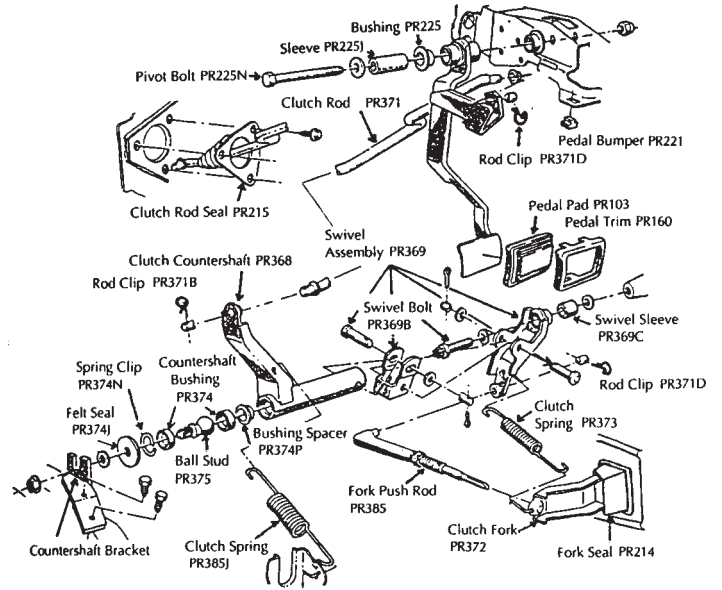

TYPICAL 1969-72 GP LINKAGE

- PR385K** 1969-72 Clutch Lingage Kit - GP (RE)..... \$259.00/kit
PR355B 1969-72 Linkage Arm Bolt Kit, 9Pc. (RE) 15.00/kit
PR368 1969-72 Clutch Countershaft (L-Shaped) w/Ball-Stud, Bushings and Clip- GP (APE)..... 40.00/ea.
PR369 1969-72 Clutch Countershaft Swivel Assembly - GP (RE)..... 45.00/ea.
PR369B 1969-72 Clutch Countershaft Swivel to Engine Bolt - GP (GM) 3.00/ea.
 Note: This is the correct 12-point bolt used to attach the swivel assembly to the engine.
PR369C 1969-72 Clutch Countershaft Swivel to Engine Bolt Sleeve - GP (AP) 4.50/ea.



PR209

- PR209** 1955-57 Accelerator Rod Boot (APE) 8.50/ea.
PR214 1965-72 Clutch Fork Boot - All (GM) 15.00/ea.



PR214



PR215

- PR215** 1969-72 Clutch Rod Seal - GP (RE) 12.00/ea.
PR215G 1969-72 Clutch Rod Seal Retainer - GP (RE)..... 16.00/ea.



PR215G



PR225

- PR221** 1967 Clutch Pedal Bumper (GM) 3.00/ea.
PR221 1969-72 Clutch Pedal Bumper - GP (GM) 3.00/ea.
PR222 1970-72 Clutch Pedal Bumper- (RE)..... 3.00/ea.

TRANS, CLUTCH, BRAKE



PR224C 1969-72 Clutch and Brake Pedal Assembly - GP (RE) Inquire
 These assemblies do not include pedal pads or push rods.

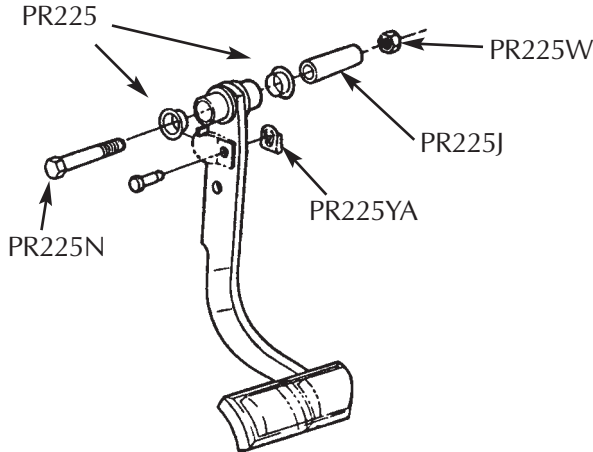

PR225 1961-77 Clutch and Brake Pedal Assembly Pivot Bushings, AT or MT (GM) \$3.50/ea.
 Usually worn, these bushings will restore your sloppy AT or MT clutch and brake pedals.

Note: Requires 2 per pedal.
PR225J 1958-77 Clutch and Brake Pedal Shaft Sleeve (7/16" ID x2 3/8" long), Cut to Length (RE) 5.00/ea.
PR225N 1969-77 Brake Pedal Pivot Bolt, All AT - GP (RP) 2.50/ea.
PR225P 1969-72 Clutch and Brake Pedal Pivot Bolt - All MT - GP (RP) 2.50/ea.
PR225W 1969-72 Clutch and Brake Pedal Pivot Bolt Lock Nut - GP (RP) 1.50/ea.
PR225YA 1969-72 Brake Clevis to Pedal Pin Retainer - GP (GM) 2.00/ea.
PR225YA 1967-72 Brake Clevis to Pedal Pin Retainer - FS (GM) 2.00/ea.



PR371 1969-72 Clutch Rod - GP (RE) 29.00/ea.
PR371B 1963-64 Clutch Rod To Pedal Nylon Bushing - FS (RE) 3.00/ea.
PR371B 1969-72 Clutch Rod To Pedal Nylon Bushing - GP (RE) 3.00/ea.
PR371D 1965-72 Clutch Rod Clip - All (AP) 1.50/ea.



PR372A 1965-72 Clutch Fork - All (RP) 21.00/ea.
 Note: PR372A is an inexpensive alternative to GM's replacement. Quality is considered to be very good.
PR372 1965-72 Clutch Fork - All (GM-RP) 65.00/ea.
 Note: PR372 Does not look like original but functions fine.



PR372CM 1965-72 Clutch Fork Ball Stud - All MT Pontiac V8 (GM) \$12.00/ea.

PR373 1965-72 Clutch Fork Push Rod Center Rattle Spring - All (RE) 11.00/ea.
PR374 1963-72 Clutch Countershaft Bushing - All (GM) 2.50/ea.

These are the nylon bushings located at the frame end of the clutch countershaft. They often wear, causing sloppy clutch linkage (2 required).

PR374J 1963-72 Clutch Countershaft Seal (GM) 4.00/ea.

This is the felt seal located at the frame bracket end of the Z-bar.

PR374N 1963-72 Clutch Countershaft Spring Clip (GM) .. 2.00/ea.

This is the spring clip that retains the countershaft bushing in the clutch countershaft.



PR373AS 1965-70 Engine Side Z Bar Bracket, FS (RE) 69.00/ea.
PR373AS 1965-70 Engine Side Z Bar Bracket w/ Ball Stud, FS (RE) 87.00/ea.
PR374P 1969-72 Clutch Countershaft Bushing Spacer - GP (RE) 7.00/ea.
PR375 1963-72 Clutch Countershaft to Frame Ball Stud - All (GM) 11.00/ea.
PR381 1965-72 Clutch Fork Push Rod Swivel (Original-Style) - All (RE) Disc.



PR381A 1965-72 OEM Clutch Fork Push Rod (RE) 20.00/ea.
 PR381A is for those applications where original equipment is a must.



PR385 1965-72 Clutch Fork Push Rod - All (GM) 25.00/ea.
 Note: PR385 is a rugged replacement push rod used by GM for heavy duty clutch applications. It is sold as a three-piece set and is stronger than the original-style rod.



PR385KD 1969-72 Clutch Spring (2-Piece) - GP (RE) 19.00/pr.
PR385KD 1961-62 Clutch Over-Center Spring (RE) 26.00/ea.

This hard-to-find spring is a necessity on 61-62 cars to aid in depressing the clutch.

TRANSMISSION CROSSMEMBER & COMPONENTS



PR282

PR282 1969-72 Transmission Crossmember With Boxed Frame - GP (RE-RP) \$169.00/ea.

Note: Crossmember does not have boxed plate on underside but will fit and function fine.

Add \$12.00 oversize fee to standard additional shipping for PR282 .

PR284 1961-70 Transmission Rear Crossmember Insulators, AT or MT - FS (APE) 21.00/pr.



PR285 1969-72 Transmission Rear Crossmember Insulators, AT or MT - GP (GM) 39.00/pr.

This is an exact match for the crossmember insulators. For a less expensive alternative to PR285, please inquire.

Comments: Excellent.

PR284A 1961-64 Transmission Crossmember To Frame Insulator Brackets, (RE) 34.00/pr.

PR284B 1965-70 Transmission Crossmember To Frame Insulator Brackets, (RE) 34.00/pr.

PR285AB 1964-72 Transmission Crossmember Insulator Brackets (RE) 29.00/pr.

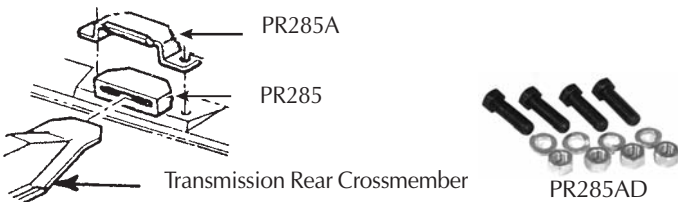

PR285A 1969-72 Transmission Crossmember Support Retainer - GP (RE) 29.00/pr.

Note: PR285A is the metal bracket that holds the rubber crossmember insulator in place on the frame rail.

PR285AD 1969-72 Crossmember Insulator Bracket to Frame Bolt Kit - GP (RE) 3.50/kit

One kit per car.

TRANSMISSION MOUNTS & HARDWARE



PR279G

PR279G 1959-60 Transmission to Crossmember Mount (RE) 38.00/ea.



PR279H

PR279H 1961-64 Transmission to Crossmember Mount, AT (AP) 38.00/ea.



PR279J

PR279J 1961-64 Transmission to Crossmember Mount, MT (Requires 2) (AP)..... \$11.00/ea.



PR279K

PR279K 1965-70 Transmission to Crossmember Mount (AP) 39.00/ea.

Note: See PR280M for replacement universal mount.



PR280

PR280 1969-72 Transmission to Crossmember Mount, AT - GP (AP) 17.00/ea.

PR280CA 1969-72 Transmission Mount to Transmission Bolt Kit - GP (RE) 2.50/kit

PR280CB 1969-72 Transmission Mount to Crossmember Bolt Kit - GP (RE) 2.50/kit

PR280D 1971-72 Transmission to Crossmember Mount - FS (AP)..... 18.00/ea.

PR280J 1973-76 Transmission to Crossmember Mount - FS (AP)..... 10.00/ea.

PR280J 1973-77 Transmission to Crossmember Mount - GP exc. '74 GP w/R.T.S. (AP) .. 10.00/ea.

PR280D 1974 Transmission to Crossmember Mount - GP w/R.T.S. (AP)..... 18.00/ea.



PR280D



PR280M

PR280M 1965-70 Urethane Transmission Mount, - AT or MT FS (AP)..... 26.00/ea.

PR280M 1969-77 Urethane Transmission Mount, - AT or MT GP (AP)..... 26.00/ea.

Note: PR280M is thicker than originals at 1 7/8". Originals were 1 3/8"

MASTER CYLINDER CAPS, BOOTS & DIAPHRAGMS



PR198X

PR198X 1955-57 Master Cylinder Dust Boot - Moraine - PB (RE)..... 28.00/ea.

TRANS, CLUTCH, BRAKE

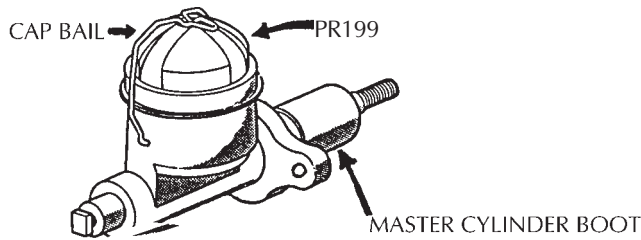

PR199 1964-66 Master Cylinder Cap (APE)..... \$16.00/ea.
 Manufactured exactly like original, this cap even has the correct instructions stamped on top. It is yellow cad-plated.



PR199A

PR199A 1964-66 Master Cylinder Cap Diaphragm (RE)... 9.00/ea.



PR199D

PR199D 1967-70 Master Cylinder Cap w/o Power Brakes (APE) 18.00/ea.
PR199E 1967-70 Master Cylinder Cap Diaphragm w/o Power Brakes (RE)..... 7.00/ea.

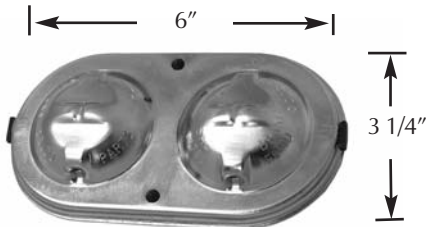

PR199G

PR199G 1969 Master Cylinder Cap w/Moraine Disc Brakes (RE)..... 19.00/ea.



PR199H

PR199H 1969 Master Cylinder Cap Diaphragm w/Moraine Disc Brakes (RE)..... 8.00/ea.



PR199J

PR199J 1970 Master Cylinder Cap w/Moraine Disc Brakes - GP (GM) \$17.00/ea.
PR199K 1970 Master Cylinder Cap Diaphragm w/Moraine Disc Brakes - GP (GM) 17.00/ea.
PR199G 1970 Master Cylinder Cap w/Moraine Disc Brakes - FS (GM)..... 19.00/ea.
PR199H 1970 Master Cylinder Cap Diaphragm w/Moraine Disc Brakes - FS (GM) 8.00/ea.



PR199M

PR199M 1971-75 Master Cylinder Cap w/Bendix Brakes - FS (GM) Disc.
PR199N 1971-75 Master Cylinder Cap Diaphragm w/Bendix Brakes - FS (GM) 18.50/ea.
PR199J 1971-75 Master Cylinder Cap w/Moraine Disc Brakes - All (GM)..... 17.00/ea.

Note: See photo above.

PR199K 1971-75 Master Cylinder Cap Diaphragm w/Moraine Disc Brakes - All (GM)..... 17.00/ea.
PR199M 1973-75 Master Cylinder Cap w/Bendix Brakes - GP (GM) Disc.

Note: See photo above.

PR199N 1973-75 Master Cylinder Cap Diaphragm w/Bendix Brakes - GP (GM)..... 18.50/ea.
PR199J 1976-77 Master Cylinder Cap - All (GM)..... 17.00/ea.

Note: See photo above.

PR199K 1976-77 Master Cylinder Cap Diaphragm - All (GM) 17.00/ea.

Since many different master cylinders were used during these years please refer to photos to identify your cap correctly.

CHROME MASTER CYLINDER CAPS



PR199LA

PR199LA 1967-70 Chrome Master Cylinder Cap w/Bail - All Exc. Disc Brakes (AP)..... 12.00/ea.
 See picture of PR199D for dimensions. Use diaphragm # PR199E.

PR199LC 1969 Chrome Master Cylinder Cap w/Bails - All w/Power Disc Brakes (AP)..... 12.00/ea.

PR199LC is the oval cap with twin bails (See PR199G). Use diaphragm # PR199H.

PR199LB 1970-77 Chrome Master Cylinder Cap w/Bail - All w/Power Disc Brakes (AP)..... 12.00/ea.

PR199LB is the rectangular cap with a single bail (See PR199J). Use diaphragm # PR199K.

MASTER CYLINDER CAP BAILS



PR199T

PR199R	1967-70	Master Cylinder Cap Bail - All exc. Power Brakes (GM)	Disc.
PR199S	1969	Master Cylinder Cap Bail w/Moraine Disc Brakes (2 required) (GM)	Disc.
PR199T	1970	Master Cylinder Cap Bail w/Moraine Disc Brakes - GP (GM)	Disc.
PR199T	1971-77	Master Cylinder Cap Bail - All w/Moraine Disc Brakes (GM)	Disc.

MASTER CYLINDER REBUILD KITS



PR201BH

PR204

WITHOUT POWER BRAKES

PR201BA	1955-57	Master Cylinder Rebuild Kit (AP)	\$27.00/ea.
PR201BC	1958	Master Cylinder Rebuild Kit (AP)	27.00/ea.
PR201BF	1959-66	Master Cylinder Rebuild Kit (AP)	Inquire
PR201BH	1967-70	Master Cylinder Rebuild Kit (AP)	45.00/ea.
PR204	1964-66	Master Cylinder Rod Boot - All exc. Power Brakes (RP)	5.00/ea.

WITH POWER DRUM BRAKES

PR201DA	1959-62	Master Cylinder Rebuild Kit w/Moraine (AP)	\$15.00/ea.
PR201DF	1963-65	Master Cylinder Rebuild Kit w/Moraine (AP)	Inquire
PR201DH	1964-65	Master Cylinder Rebuild Kit w/Bendix (AP)	Inquire
PR201DK	1966	Master Cylinder Rebuild Kit (AP)	30.00/ea.
PR201BH	1967-70	Master Cylinder Rebuild Kit w/ Moraine (AP)	45.00/ea.
PR201DM	1967-70	Master Cylinder Rebuild Kit w/ Bendix (AP)	39.00/ea.
PR201DP	1969	Master Cylinder Rebuild Kit - All GP w/ Moraine Cylinder, Exc. Disc Brakes (RP)	29.00/ea.

WITH POWER DISC BRAKES

PR201FA	1967-68	Master Cylinder Rebuild Kit (AP)	50.00/ea.
PR201FA	1969	Master Cylinder Rebuild Kit w/Bendix FS (AP)	50.00/ea.
PR201FB	1969	Master Cylinder Rebuild Kit - All GP with Disc Brakes Exc. 9 1/2"x2" Rear Drum (RP)	29.00/ea.
PR201FC	1969-77	Master Cylinder Rebuild Kit w/Moraine (AP)	29.00/ea.
PR201FD	1969-77	Master Cylinder Rebuild Kit - All GP with Disc Brakes "Bendix Cylinder" Exc. 11"x2" Rear Drum (RP)	29.00/ea.
PR201FF	1971-72	Master Cylinder Rebuild Kit w/Bendix FS (AP)	39.00/ea.
PR201FH	1973-76	Master Cylinder Rebuild Kit w/Bendix FS (AP)	39.00/ea.

Using these kits allows you to refurbish your original master cylinder. Many times rebuilding your original is preferable to purchasing incorrect replacements.

Note: To protect your master cylinder from rust use our cast-iron spray gray paint on page 159.

MASTER CYLINDERS (ALL EXC. '69-77 GP)



PR202BC	1958	Master Cylinder, All w/ MB (RP)	\$92.00/ea.
PR202BC	1959-60	Master Cylinder, All w/ PB and Bendix Booster (RP)	92.00/ea.
PR202BE	1959-60	Master Cylinder, All w/ PB and Moraine Booster (RP)	92.00/ea.
PR202BD	1961	Moraine Master Cylinder, All w/ PB (RP)	92.00/ea.
PR202BM	1961	Bendix Master Cylinder, All w/ PB (RP)	92.00/ea.
PR202BM	1962	Master Cylinder, All w/ PB and 4 Mounting Bolts (RP)	92.00/ea.
PR202BR	1962	Master Cylinder, All w/ PB and 2 Mounting Bolts - New (RP)	69.00/ea.
PR202BW	1962-66	Master Cylinder, All w/ MB - New (RP)	69.00/ea.
PR202BZ	1963-65	Master Cylinder, All w/ PB - New (RP)	69.00/ea.
PR202CB	1966	Master Cylinder, All w/ PB - Reman (RP)	45.00/ea.

PR202CB requires a refundable \$12.00 core charge. Core must be rebuildable and returned in original box.

PR202CF	1967-70	Bendix Master Cylinder - All FS exc. Disc Brakes (RP)	72.00/ea.
PR202CH	1967-70	Moraine Master Cylinder - All FS exc. Disc Brakes (RP)	124.00/ea.
PR202CK	1967-70	Bendix Master Cylinder - All FS w/Power Disc Brakes (RP)	Disc.
PR202CM	1970-72	Moraine Master Cylinder - All FS w/Power Disc Brakes (RP)	69.00/ea.
PR202CL	1970-77	Correct Master Cylinder - All FS w/Power Disc Brakes (RE)	79.00/ea.
PR202CP	1971-72	Bendix Master Cylinder - All FS w/Power Disc Brakes (RP)	72.00/ea.
PR202CM	1973-77	Master Cylinder - All FS w/Power Disc Brakes (RP)	69.00/ea.

MASTER CYLINDERS (1969-77 GRAND PRIX)



PR203A	1969	Bendix Master Cylinder - All GP w/ 11" x 2" Rr Drum, exc. Disc Brakes - 1-1/8" Bore(RP)	72.00/ea.
PR203D	1969	Moraine Master Cylinder - All GP w/ 11" x 2" Rr Drum, exc. Disc Brakes - 1" Bore (RP)	124.00/ea.
PR203G	1969	Master Cylinder - All GP w/ 9 1/2" x 2" Rr Drum, exc. Disc Brakes (RP)	69.00/ea.
PR203H	1969-77	Correct Master Cylinder w/Bleeder Screws All GP w/Power Disc	79.00/ea.
PR203J	1969-77	Master Cylinder - All GP w/ Disc Brakes, exc. 1969 GP w/ 11" x 2" Rr Drum (RP)	69.00/ea.

Note: PR202BC-PR203J are new master cylinders, not remanufactured unless otherwise indicated.



PR207LL

PR207LL Brake Fluid Delco Supreme 11 16oz (GM)..... \$9.00/ea
Recommended for all vehicles requiring DOT 3 brake fluid.



PR207LM

PR207LM Brakes Parts Cleaner 18oz (GM) 8.00/ea.
Spray Can - formulated to remove oil, grease, brake fluid, dirt and contaminants from brake components.

 Aerosol cans and any fluids cannot be shipped by air or outside the Continental United States.

BRAKE BOOSTER COMPONENTS



PR199XA

PR199XA 1969-72 Power Brake Booster to Firewall Dust Seal (RE) 10.00/ea.

This is the hard white plastic shield at the back of the booster that seats to the firewall keeping dust and debris out. This seal is commonly cracked or missing.



PR200

PR200 1964-77 Power Brake Booster Vacuum Check Valve w/Grommet (GM-RP) 11.00/ea.

Note: This valve regulates and maintains vacuum in the brake booster.

Comments: May not have the same markings as your original.

PR200B 1964-77 Power Brake Booster Vacuum Check Valve Grommet (GM) 9.00/ea.

PR200C 1963-77 Power Brake Vacuum Hose (RP) 3.00/ft.



PR200B



PR668

PR668 1969-70 Brake Booster Clip, All GP w/PB (RE)... 9.50/ea

This clip secures the brake lines to the drivers side of the brake booster bracket. Correct black plating.

PR203L 1963-77 Master Cylinder to Brake Booster Nuts (RE) 2.00/pr.



PR203L



WK



EA



PB

PR200KA 1969-72 Power Brake Booster Tag "WK" (RE)..... 6.00/ea.

PR200KB 1969-72 Power Brake Booster Tag "EA" (RE) 6.00/ea.

PR200KC 1969-72 Power Brake Booster Tag "PB" (RE) 6.00/ea.

PROPORTIONING VALVES & BRACKETS



PR200DB

PR200DB 1969 Disc Brake Proportioning Valve and Bracket - GP (RE) \$89.00/ea.



PR200DD

PR200DD 1967-70 Disc Brake Proportioning Valve Bracket - FS (RE) 23.00/ea.

PR200DG 1969-70 Disc Brake Proportioning Valve Bracket - GP (RE)..... 29.00/ea.

PR200DD and PR200DG secure the proportioning valve to the brake booster.



PR200DJ

PR200DJ 1970 Rear Axle Brake Line Distribution Block (RE) 63.00/ea



PR200DL

PR200DL 1970 Disc Brake Rear Proportioning Valve Bracket - GP (RE)..... 29.00/ea.

This bracket secures the rear brake proportioning valve to the frame crossmember located just before the rear end.

PR200DP 1969-71 Disc Brake Distribution Valve Bracket - GP (RE)..... 31.00/ea.

This bracket secures the distribution valve to the frame on the driver's side below the master cylinder.



PR200DP

REPLACEMENT POWER BRAKE BOOSTERS



PR200JL

PR200JJ 1963-66 Power Brake Booster (RP) Inquire

PR200JK 1967-68 Power Brake Booster - All exc. Disc Brakes (RP) Disc.

PR200JL 1969-72 Power Brake Booster - GP exc. Disc Brakes (RP) 109.00/ea.

PR200JN 1969-72 Power Brake Booster - GP w/ Disc Brakes (RP)..... 109.00/ea.

These boosters are replacements that do not have the same stampings or plating as originals. The PR199XA dust seal will need to be ordered separately as it is not included with PR200JL-PR200JN.

PR200JL & PR200JR requires a \$20.00 refundable core charge. Core must be rebuildable and returned in original box.

Power brake boosters continue on next page.

Power brake boosters continued.

**ORIGINAL STYLE
BRAKE BOOSTERS**

- PR200JP** 1963-66 Original Style Power Brake Booster (RE) Inquire
PR200JR 1969-72 Original Style Power Brake Booster
 - GP (RE)..... \$179.00/ea.

PR200JR has the original type stamping with the correct gold-cad plating.

- PR200LD** 1969-72 Original Style Power Brake Booster
 - GP (RE) 149.00/ea.

PR200LD does not have the original type stamping with the correct gold-cad plating.

Quality: Excellent.

ELECTRIC VACUUM PUMP



- PR200YS** 1955-77 Electric Vacuum Pump Kit (AP) 256.00/kit
 Designed for engines that do not produce enough vacuum needed to supply brake boosters. complete with hardware and instructions.

PARKING BRAKE CABLES

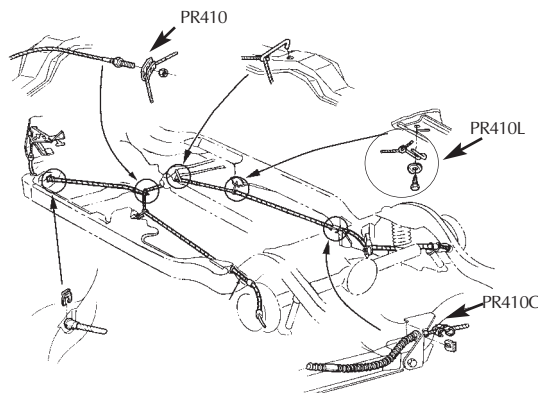

KITS

- PR393BF** 1961-62 Parking Brake Cable Kit - Catalina/GP (RP) 190.00/set
PR393BK 1961-62 Parking Brake Cable Kit - All Bonneville and Starchief (RP)..... 190.00/set
PR393BW 1963-64 Parking Brake Cable Kit - All Except Bonneville and Starchief (RP)..... 209.00/set

Cable kits include all hardware and cables needed for your complete parking brake set-up.

FRONT

- PR393AB** 1955-56 Front Parking Brake Cable - All Starchief exc. Wagon (RP) 65.00/ea.
PR393AP 1958 Front Parking Brake Cable - All (RP) 65.00/ea.
PR393BD 1961-62 Front Parking Brake Cable - All (RP) 70.00/ea.
PR393BN 1963-64 Front Parking Brake Cable - All exc. Bonneville (RP) 72.00/ea.
PR393BP 1963-64 Parking Brake Cable - Bonneville (RP) . 69.00ea.
PR395 1965-67 Front Parking Brake Cable - GP (RP)..... 31.00/ea.
PR395M 1969-72 Front Parking Brake Cable - GP (RP)..... 72.00/ea.
PR396 1965-70 Front Parking Brake Cable - Bonneville (RP) 72.00/ea.
PR396AA 1965-70 Front Parking Brake Cable - All exc. Bonneville (RP) 69.00/ea.
PR405 1973-76 Front Parking Brake Cable - All exc. GP (AP) 37.00/ea.
PR407 1973-77 Front Parking Brake Cable - GP (AP)..... 31.00/ea.

CENTER

- PR395A** 1965-67 Center Parking Brake Cable - GP (RP)... \$19.00/ea.
PR396A 1965-70 Center Parking Brake Cable - All exc. GP (RE)..... 26.00/ea.
PR402 1969-72 Center Parking Brake Cable - GP (GM) . 33.00/ea.
PR403 1971-72 Center Parking Brake Cable - FS (GM) .. 29.00/ea.
PR405A 1973-76 Center Parking Brake Cable - All exc. GP (AP) 24.00/ea.
PR407A 1973-75 Center Parking Brake Cable w/o Catalytic Converter - GP (AP) 26.00/ea.
PR407B 1975-77 Center Parking Brake Cable w/Catalytic Converter - GP (GM) Disc.

REAR

- PR393AF** 1955-56 Rear Parking Brake Cable - All Starchief exc. Wagon (RP) 105.00/ea.
PR393AJ 1957 Rear Parking Brake Cable - All Starchief exc. Wagon (RP) 105.00/ea.
PR393AT 1958 Rear Parking Brake Cable - All Starchief and Superchief exc. Wagon (RP) 105.00/ea.
PR393BA 1959-60 Rear Parking Brake Cable - All Catalina (RP)..... 105.00/ea.
PR393BG 1961-62 Rear Parking Brake Cable - All Bonneville and Starchief (RP)..... 62.00/ea.

Note: 2 required

- PR393BGC** 1961-62 Rear Parking Brake Cable - All Catalina and 62 GP (RP) 62.00/ea.
PR393BR 1963-64 Rear Parking Brake Cable - All exc. Bonneville & Starchief (RP) 62.00/ea.
PR393BS 1963-64 Rear Parking Brake Cable - Bonneville & Starchief (RP) 69.00/ea.

Note: 2 required.

- PR395B** 1965-67 Rear Parking Brake Cable, RH or LH - GP (GM)..... 28.00/ea.
PR396B 1965-70 Rear Parking Brake Cable, RH or LH - All exc. GP (RP)..... 41.00/ea.
PR400 1969-72 Rear Parking Brake Cable, RH or LH - GP (GM) 28.00/ea.
PR404 1971-72 Rear Parking Brake Cable, RH or LH, w/11" Brakes -FS (AP) 36.00/ea.
PR405B 1973-76 Rear Parking Brake Cable, RH or LH - All exc. GP (AP)..... 36.00/ea.
PR405B 1973-77 Rear Parking Brake Cable, RH or LH - GP (AP)..... 36.00/ea.

TRANS, CLUTCH, BRAKE

OWN OTHER PONTIACS?

Call or visit www.amesperf.com for your Free:



**1967-1981
Firebird
Trans Am
Formula
Catalog**

or

**1964-1977
Pontiac
GTO
Lemans
Tempest
Catalog**



PARKING BRAKE COMPONENTS



PR410

PR410 1961-77 Parking Brake Cable Equalizer (GM) \$6.00/ea.



PR410C

PR410C 1961-77 Parking Brake Cable Connector
(2 Required) (GM) 2.00/ea.



PR410CB

PR410CB 1961-77 Parking Brake Cable Connector, Correct
Style (2 Required) (RE) 3.00/ea.



PR410D

PR410D 1955-77 Front Parking Brake Cable Return
Spring Retainer (RP)..... 1.50/ea.



PR410F

PR410F 1961-77 Parking Brake Cable Clip, Front or
Rear (RE)..... 1.50/ea.



PR410L

PR410L 1964 Front of Rear Brake Cable Guide
and Hardware (RE)..... 6.00/kit

This is the hard-to-find often missing brake cable guide that the rear cable goes through.



PR410T

PR410T 1969-72 Parking Brake Cable Guide - GP (APE) . 5.50/ea.

PR410T 1973-76 Parking Brake Cable Guide - FS (APE) .. 5.50/ea.

Usually worn or missing, these cable guides are necessary for proper parking brake operation. Requires 2 per car.

Note: Beware of the S-shaped guide currently available from GM. Because of its large diameter, you need to alter your floor brace to install properly.



PR415J

PR415J 1969-72 Parking Brake Release Handle - GP
(GM-RP) 8.00/ea.

Although not an exact replacement, this handle functions fine. The print and contours of the handle differ from the original design.



PR409B

PR409B 1969-72 Parking Brake Pedal Assembly - GP (RE) 89.00/ea.

BRAKE LINE CLIPS



PR669

PR669 Steel Double-Line Clip w/Rivet, Red (RE) ... \$6.00/ea.



PR678S

PR678S Steel Line Clip, Double Line
Fits 1/4" and 3/8" Lines (Silver) (RE)..... 2.00/ea.



PR678T

PR678T Steel Line Clip, Fits 1/4" and 5/16"
Lines (Black) (RE)..... 2.00/ea.



PR679

PR679 Steel Line Clip, Fits 5/16" and 5/16"
Lines (Black) (AP) 2.00/ea.



PR679A

PR679A Steel Line Clip, Fits 1/4" and 3/8"
Lines (Black) (AP) 2.00/ea.



PR679AC

PR679AC Push-In 3/16" Brake-Line Clip, Black (RE) 2.00/ea.



PR679AD

PR679AD Push-In 1/4" Brake-Line Clip, Black (RE) 2.00/ea.



PR679B - PR679E

PR679B Steel Line Clip, Fits Single 3/16" Line,
Silver (3/16" Bolt Hole) (AP) 2.00/ea.

PR679C Steel Line Clip, Fits Single 1/4" Line,
Silver (1/4" Bolt Hole) (AP) 2.00/ea.

PR679D Steel Line Clip, Fits Single 5/16" Line,
Silver (3/16" Bolt Hole) (AP) 2.00/ea.

PR679E Steel Line Clip, Fits Single 3/8" Line,
Silver (3/16" Bolt Hole) (AP) 2.00/ea.

PR679F Steel Line Clip w/ Tab, Fits Single
1/4" Line, Blue (5/32" Bolt Hole) (AP) 4.00/ea.

PR679G Steel Line Clip w/ Tab, Fits Single
3/8" Line, Blue (5/16" Bolt Hole) (AP) 2.00/ea.

PR679H Steel Line Clip w/ Tab, Fits Single
3/16" Line, Yellow Zinc (5/32" Bolt
Hole) (AP) 3.00/ea.



- | | | | |
|--|--------|---|------------|
| | PR679J | Steel Line Clip, Double Line, Fits 3/8" and 1/4" Lines, Silver (5/16" Bolt Hole) (AP)..... | \$4.00/ea. |
| | PR679K | Steel Line Clip, Double Line, Fits 3/16" and 1/4" Lines, Silver (5/16" Bolt Hole) (AP)..... | 4.00/ea. |



- | | | | |
|--|--------|---|----------|
| | PR679L | Steel Line Clip, Fits 5/8" Single Line, Silver (5/32" Bolt Hole) (AP) | 2.00/ea. |
| | PR679M | Steel Line Clip w/ Tab, Fits 3/8" Single Line, Blue (5/32" Bolt Hole) (AP)..... | 3.00/ea. |



- | | | | |
|--|--------|---|-----------|
| | PR681 | 1955-57 Brake Line Clip Set 16Pc. (RP)..... | 13.00/set |
| | PR681A | 1958-60 Brake Line Clip Set 16Pc. (RE)..... | 13.00/set |
| | PR681B | 1961-64 Brake Line Clip Set 10Pc. (RE)..... | 29.50/set |
| | PR681C | 1965 Brake Line Clip Set 10Pc. (RE)..... | 25.50/set |
| | PR681D | 1966-67 Brake Line Clip Set 11Pc. (RE)..... | 29.50/set |
| | PR681E | 1968-69 Brake Line Clip Set 14Pc. (RE)..... | 32.00/set |
| | PR681F | 1970 Brake Line Clip Set 17Pc. (RE)..... | 27.00/set |
| | PR681G | 1971-76 Brake Line Clip Set 34Pc. (RE)..... | 48.00/set |

BRAKE LINE & SHIELDING



- | | | | |
|--|--------|---|------------|
| | PR695 | 1955-77 1/4" Brake Line Tubing (25 ft roll) (AP)... | 20.00/roll |
| | PR696 | 1955-77 3/16" Brake Line Tubing (25 ft roll) (AP)..... | 24.00/roll |
| | PR697J | 1955-77 3/16" Stainless Steel Brake line Tubing Armor (4ft section) (AP)..... | 15.00/ea. |
| | PR697K | 1955-77 1/4" Stainless Steel Brake line Tubing Armor (4ft section) (AP)..... | 15.00/ea. |

PRE-BENT FRONT BRAKE LINES

These lines are considered the best in the industry. Stainless steel lines are made from high-quality 304 stainless.

Other years are becoming available. Please inquire if you do not see your application listed.

Add \$8.00 oversize fee to standard shipping for front brake lines.

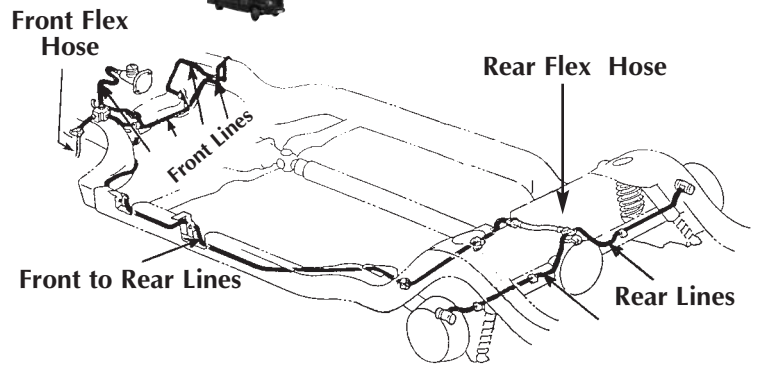

- | | | | |
|---------|---------|---|-------------|
| PR703A | 1958 | Front Brake Lines, Standard Drum 4pc. -Steel (RE)..... | \$68.00/set |
| PR703AS | 1958 | Front Brake Lines, Standard Drum 4pc. -Stainless Steel (RE) | 88.00/set |
| PR704A | 1959-60 | Front Brake Lines, Standard Drum 4pc. -Steel (RE)..... | 68.00/set |
| PR704AS | 1959-60 | Front Brake Lines, Standard Drum 4pc. -Stainless Steel (RE) | 88.00/set |
| PR704B | 1959-60 | Front Brake Lines, Power Drum 4pc. -Steel (RE)..... | 68.00/set |
| PR704BS | 1959-60 | Front Brake Lines, Power Drum 4pc. -Stainless Steel (RE) | 88.00/set |
| PR705A | 1961 | Front Brake Lines, Standard Drum 3pc. -Steel (RE)..... | 68.00/set |
| PR705AS | 1961 | Front Brake Lines, Standard Drum 3pc. -Stainless Steel (RE) | 88.00/set |
| PR705D | 1961 | Front Brake Lines, Power Drum 3pc. -Steel (RE)..... | 68.00/set |
| PR705DS | 1961 | Front Brake Lines, Power Drum 3pc. -Stainless Steel (RE) | 88.00/set |
| PR705N | 1962-64 | Front Brake Lines, Standard Drum 3pc. -Steel (RE)..... | 68.00/set |
| PR705NS | 1962-64 | Front Brake Lines, Standard Drum 3pc. -Stainless Steel (RE) | 88.00/set |
| PR705P | 1963-64 | Front Brake Lines, Power Drum 3pc. -Steel (RE)..... | 68.00/ea. |
| PR705PS | 1963-64 | Front Brake Lines, Power Drum 3pc. -Stainless Steel (RE) | 88.00/ea. |
| PR705S | 1965 | Front Brake Lines, Standard Drum 3pc. -Steel (RE)..... | 68.00/set |
| PR705SS | 1965 | Front Brake Lines, Standard Drum 3pc. -Stainless Steel (RE) | 88.00/set |
| PR705W | 1965 | Front Brake Lines, Power Drum 3pc. -Steel (RE)..... | 68.00/set |
| PR705WS | 1965 | Front Brake Lines, Power Drum 3pc. -Stainless Steel (RE) | 88.00/set |
| PR706D | 1966 | Front Brake Lines, Standard Drum 3pc. -Steel (RE)..... | 68.00/set |
| PR706DS | 1966 | Front Brake Lines, Standard Drum 3pc. -Stainless Steel (RE) | 88.00/set |
| PR706H | 1966 | Front Brake Lines, Power Drum 3pc. -Steel (RE)..... | 68.00/set |
| PR706HS | 1966 | Front Brake Lines, Power Drum 3pc. -Stainless Steel (RE) | 88.00/set |
| PR706L | 1967-68 | Front Brake Lines, Standard Drum 4pc. -Steel (RE)..... | 68.00/set |
| PR706LS | 1967-68 | Front Brake Lines, Standard Drum 4pc. -Stainless Steel (RE) | 88.00/set |

PR706P	1967-68	Front Brake Lines, Power Drum 4pc. -Steel (RE).....	\$68.00/set
PR706PS	1967-68	Front Brake Lines, Power Drum 4pc. -Stainless Steel (RE)	88.00/set
PR706T	1967-68	Front Brake Lines, Power Disc 5pc. -Steel (RE).....	68.00/set
PR706TS	1967-68	Front Brake Lines, Power Disc 5pc. -Stainless Steel (RE).....	88.00/set
PR707	1969	Front Brake Lines, Power Drum 4pc. - GP -Steel (RE)	68.00/set
PR707S	1969	Front Brake Lines, Power Drum 4pc. - GP -Stainless Steel (RE).....	88.00/set
PR707A	1969	Front Brake Lines, Power Disc 5pc. - GP -Steel (RE)	68.00/set
PR707AS	1969	Front Brake Lines, Power Disc 5pc. - GP -Stainless Steel (RE).....	88.00/set
PR707B	1969	Front Brake Lines, Power Drum 4pc. - FS -Steel (RE).....	68.00/set
PR707BS	1969	Front Brake Lines, Power Drum 4pc. - FS -Stainless Steel (RE).....	88.00/set
PR707G	1969	Front Brake Lines, Power Disc 5pc. - FS -Steel (RE).....	68.00/set
PR707GS	1969	Front Brake Lines, Power Disc 5pc. - FS -Stainless Steel (RE).....	88.00/set
PR707J	1970	Front Brake Lines, Power Drum 5pc. - FS -Steel (RE).....	68.00/set
PR707JS	1970	Front Brake Lines, Power Drum 5pc. - FS -Stainless Steel (RE).....	88.00/set
PR707N	1970	Front Brake Lines, Power Disc 5pc. - FS -Steel (RE).....	68.00/set
PR707NS	1970	Front Brake Lines, Power Disc 5pc. - FS -Stainless Steel (RE).....	88.00/set
PR707P	1970	Front Brake Lines, Power Drum 4pc. - GP -Steel (RE)	68.00/set
PR707PS	1970	Front Brake Lines, Power Drum 4pc. - GP -Stainless Steel (RE).....	88.00/set
PR707T	1970	Front Brake Lines, Power Disc 6pc. - GP -Steel (RE)	68.00/set
PR707TS	1970	Front Brake Lines, Power Disc 6pc. - GP -Stainless Steel (RE).....	88.00/set
PR708B	1971-72	Front Brake Lines, Power Disc 4pc. - GP -Steel (RE)	68.00/ea.
PR708C	1971-72	Front Brake Lines, Power Disc 4pc. - GP -Stainless Steel (RE).....	88.00/ea.

FRONT CALIPER LINES

PR710R	1967-68	Front Caliper Lines, Power Disc 2pc. -Steel (RE).....	Inquire
PR710RS	1967-68	Front Caliper Lines, Power Disc 2pc. -Stainless Steel (RE)	Inquire

PR710R and PR710RS are the lines that run from the inner half to the outer half of the 4 piston calipers.

PRE-BENT FRONT TO REAR BRAKE LINES

Other years are becoming available. Please inquire if you do not see your application listed.

PR719B	1958	Front to Rear Brake Line, Bonneville Standard Drum -Steel (RE)	68.00/ea.
PR719BS	1958	Front to Rear Brake Line, Bonneville Standard Drum -Stainless Steel (RE).....	88.00/ea.
PR720A	1959-60	Front to Rear Brake Line, Catalina -Steel (RE).....	68.00/ea.
PR720AA	1959-60	Front to Rear Brake Line, Catalina -Stainless Steel (RE)	88.00/ea.
PR720AB	1959-60	Front to Rear Brake Line, Bonneville & Star Chief -Steel (RE).....	68.00/ea.
PR720AC	1959-60	Front to Rear Brake Line, Bonneville & Star Chief - Stainless Steel (RE)	88.00/ea.
PR720B	1961-62	Front to Rear Brake Line, Catalina & GP - Steel (RE)	68.00/ea.

PR720BS	1961-62	Front to Rear Brake Line, Catalina & GP - Stainless Steel (RE).....	\$88.00/ea.
PR720F	1961-62	Front to Rear Brake Line, Bonneville - Steel (RE)	68.00/ea.
PR720FS	1961-62	Front to Rear Brake Line, Bonneville - Stainless Steel (RE).....	88.00/ea.
PR720L	1963-64	Front to Rear Brake Line, Catalina - Steel (RE)	68.00/ea.
PR720M	1963-64	Front to Rear Brake Line, Catalina - Stainless Steel (RE).....	88.00/ea.
PR720N	1963-64	Front to Rear Brake Line, Bonneville & Star Chief - Steel (RE)	68.00/ea.
PR720P	1963-64	Front to Rear Brake Line, Bonneville & Star Chief - Stainless Steel (RE)	88.00/ea.
PR721A	1965	Front to Rear Brake Line, Catalina & GP - Steel (RE)	68.00/ea.
PR721AB	1965	Front to Rear Brake Line, Catalina & GP - Stainless Steel (RE).....	88.00/ea.
PR721B	1965	Front to Rear Brake Line, Bonneville - Steel (RE)	68.00/ea.
PR721BS	1965	Front to Rear Brake Line, Bonneville - Stainless Steel (RE).....	88.00/ea.
PR721J	1966	Front to Rear Brake Line, Catalina & GP - Steel (RE)	68.00/ea.
PR721JS	1966	Front to Rear Brake Line, Catalina & GP - Stainless Steel (RE).....	88.00/ea.
PR721L	1966	Front to Rear Brake Line, Bonneville - Steel (RE)	68.00/ea.
PR721LS	1966	Front to Rear Brake Line, Bonneville - Stainless Steel (RE).....	88.00/ea.
PR722B	1967-68	Front to Rear Brake Line, Catalina & GP - Steel (RE)	68.00/ea.
PR722BS	1967-68	Front to Rear Brake Line, Catalina & GP - Stainless Steel (RE).....	88.00/ea.
PR722D	1967-68	Front to Rear Brake Line, Bonneville - Steel (RE)	68.00/ea.
PR722DS	1967-68	Front to Rear Brake Line, Bonneville - Stainless Steel (RE).....	88.00/ea.
PR722G	1969-70	Front to Rear Brake Line, Catalina - Steel (RE)	Inquire
PR722GS	1969-70	Front to Rear Brake Line, Catalina - Stainless Steel (RE).....	Inquire
PR722F	1969-70	Front to Rear Brake Line, Bonneville - Steel (RE)	Inquire
PR722FS	1969-70	Front to Rear Brake Line, Bonneville - Stainless Steel (RE).....	Inquire
PR723B	1969	Front to Rear Brake Line, GP -Steel (RE)	68.00/ea.
PR723BS	1969	Front to Rear Brake Line, GP -Stainless Steel (RE).....	88.00/ea.
PR723C	1970	Front to Rear Brake Line, Power Disc - 2pc. - GP - Steel (RE)	68.00/ea.
PR723CS	1970	Front to Rear Brake Line, Power Disc - 2pc. - GP - Stainless Steel (RE) ...	88.00/ea.
PR723F	1971-72	Front to Rear Brake Line, GP - Steel (RE).....	68.00/ea.
PR723FS	1971-72	Front to Rear Brake Line, GP - Stainless Steel (RE)	88.00/ea.
PR723G	1973-77	Front To Rear Brake Line, Power Disc - GP - Steel (RE).....	68.00/ea.
PR723GS	1973-77	Front To Rear Brake Line, Power Disc - GP - Stainless Steel (RE) ...	88.00/ea.

Add \$30.00 oversize fee to standard shipping for "Front to Rear" lines.



PRE-BENT BRAKE LINES - REAR

Other years are becoming available. Please inquire if you do not see your application listed.

PR730A	1955	Rear Brake Lines- Steel (RE).....	36.00/set
PR730AS	1955	Rear Brake Lines- Stainless Steel (RE) ...	47.00/set
PR730C	1956	Rear Brake Lines- Steel (RE).....	36.00/set

PR730CS	1956	Rear Brake Lines- Stainless Steel (RE)	\$47.00/set
PR730D	1957	Rear Brake Lines- Steel (RE).....	36.00/set
PR730DS	1957	Rear Brake Lines- Stainless Steel (RE)	47.00/set
PR730E	1958	Rear Brake Lines- Steel (RE).....	36.00/set
PR730ES	1958	Rear Brake Lines- Stainless Steel (RE)	47.00/set
PR730G	1959	Rear Brake Lines- Steel (RE).....	36.00/set
PR730GS	1959	Rear Brake Lines- Stainless Steel (RE)	47.00/set
PR730H	1960	Rear Brake Lines- Steel (RE).....	36.00/set
PR730HS	1960	Rear Brake Lines- Stainless Steel (RE)	47.00/set
PR731A	1961	Rear Brake Lines- Steel (RE).....	36.00/set
PR731AS	1961	Rear Brake Lines- Stainless Steel (RE)	47.00/set
PR731H	1962-64	Rear Brake Lines- Steel (RE).....	36.00/set
PR731HS	1962-64	Rear Brake Lines- Stainless Steel (RE)	47.00/set
PR731L	1965	Rear Brake Lines- Steel (RE).....	36.00/set
PR731LS	1965	Rear Brake Lines- Stainless Steel (RE)	47.00/set
PR731R	1966	Rear Brake Lines- Steel (RE).....	36.00/set
PR731RS	1966	Rear Brake Lines- Stainless Steel (RE)	47.00/set
PR732B	1967-68	Rear Brake Lines- Steel (RE).....	36.00/set
PR732BS	1967-68	Rear Brake Lines- Stainless Steel (RE)	47.00/set
PR733B	1969	Rear Brake Lines, GP - Steel (RE)	36.00/set
PR733BS	1969	Rear Brake Lines, GP - Stainless Steel (RE)	47.00/set
PR733C	1970-72	Rear Brake Lines, GP - Steel (RE)	36.00/set
PR733CS	1970-72	Rear Brake Lines, GP - Stainless Steel (RE)	47.00/set
PR733G	1973-77	Rear Brake Line Set, GP - Steel (RE)	36.00/ea.
PR733GS	1973-77	Rear Brake Line Set, GP -Stainless Steel (RE).....	47.00/ea.

COMPLETE PRE-BENT BRAKE LINE SETS

Other years are becoming available. Please inquire if you do not see your application listed.

Add \$30.00 oversize fee to standard shipping for complete brake line kits.



PR735B	1955	Complete Brake Line Set, Standard Drum, 6pc.-Chieftain - Steel (RE)	155.00/set
PR735BS	1955	Complete Brake Line Set, Standard Drum, 6pc. - Chieftain - Stainless Steel (RE)	187.00/set
PR735C	1955	Complete Brake Line Set, Power Drum, 6pc. - Chieftain -Steel (RE)	155.00/set
PR735CS	1955	Complete Brake Line Set, Power Drum, 6pc. - Chieftain - Stainless Steel (RE)	187.00/set
PR735D	1955	Complete Brake Line Set, Standard Drum, 6pc. - Star Chief - Steel (RE).....	155.00/set
PR735DS	1955	Complete Brake Line Set, Standard Drum, 6pc. - Star Chief - Stainless Steel (RE)	187.00/set
PR735E	1955	Complete Brake Line Set, Power Drum, 6pc. - Star Chief - Steel (RE).....	155.00/set
PR735ES	1955	Complete Brake Line Set, Power Drum, 6pc. - Star Chief - Stainless Steel (RE)	187.00/set
PR736B	1956	Complete Brake Line Set, Standard Drum, 6pc. - Chieftain - Steel (RE).....	155.00/set
PR736BS	1956	Complete Brake Line Set, Standard Drum, 6pc. - Chieftain - Stainless Steel (RE)	187.00/set
PR736C	1956	Complete Brake Line Set, Power Drum, 6pc. - Chieftain - Steel (RE).....	155.00/set
PR736CS	1956	Complete Brake Line Set, Power Drum, 6pc. - Chieftain - Stainless Steel (RE)	187.00/set
PR736D	1956	Complete Brake Line Set, Standard Drum, 6pc. - Star Chief - Steel (RE).....	155.00/set
PR736DS	1956	Complete Brake Line Set, Standard Drum, 6pc. - Star Chief - Stainless Steel (RE)	187.00/set

PR736E	1956	Complete Brake Line Set, Power Drum, 6pc. - Star Chief - Steel (RE)	155.00/set
PR736ES	1956	Complete Brake Line Set, Power Drum, 6pc. - Star Chief - Stainless Steel (RE)	\$187.00/set
PR737B	1957	Complete Brake Line Set, Standard Drum, 6pc. - Chieftain - Steel (RE).....	155.00/set
PR737BS	1957	Complete Brake Line Set, Standard Drum, 6pc. - Chieftain - Stainless Steel (RE)	187.00/set
PR737C	1957	Complete Brake Line Set, Power Drum, 6pc. - Chieftain - Steel (RE).....	155.00/set
PR737CS	1957	Complete Brake Line Set, Power Drum, 6pc. - Chieftain - Stainless Steel (RE)	187.00/set
PR737D	1957	Complete Brake Line Set, Standard Drum, 6pc. - Star Chief - Steel (RE)	155.00/set
PR737DS	1957	Complete Brake Line Set, Standard Drum, 6pc. - Star Chief - Stainless Steel (RE)	187.00/set
PR737E	1957	Complete Brake Line Set, Power Drum, 6pc. - Star Chief - Steel (RE).....	155.00/set
PR737ES	1957	Complete Brake Line Set, Power Drum, 6pc. - Star Chief - Stainless Steel (RE)	187.00/set
PR738B	1958	Complete Brake Line Set, Standard Drum, 7pc. - All - Steel (RE)	155.00/set
PR738BS	1958	Complete Brake Line Set, Standard Drum, 7pc. - All - Stainless Steel (RE)	187.00/set
PR739B	1959-60	Complete Brake Line Set, Standard Drum, 7pc. - Bonneville - Steel (RE)	155.00/set
PR739BS	1959-60	Complete Brake Line Set, Standard Drum, 7pc. - Bonneville - Stainless Steel (RE) ..	187.00/set
PR739C	1959-60	Complete Brake Line Set, Standard Drum, 7pc. - Catalina - Steel (RE).....	155.00/set
PR739CS	1959-60	Complete Brake Line Set, Standard Drum, 7pc. - Catalina - Stainless Steel (RE)	187.00/set
PR739D	1959-60	Complete Brake Line Set, Power Drum, 7pc. - Bonneville - Steel (RE)	155.00/set
PR739DS	1959-60	Complete Brake Line Set, Power Drum, 7pc. - Bonneville - Stainless Steel (RE) ..	187.00/set
PR739E	1959-60	Complete Brake Line Set, Power Drum, 7pc. - Catalina - Steel (RE).....	155.00/set
PR739ES	1959-60	Complete Brake Line Set, Power Drum, 7pc. - Catalina - Stainless Steel (RE)	187.00/set
PR740J	1961	Complete Brake Line Set, Standard Drum, 7pc. - Catalina - Steel (RE).....	155.00/set
PR740JS	1961	Complete Brake Line Set, Standard Drum, 7pc. - Catalina - Stainless Steel (RE)	187.00/set
PR740M	1961	Complete Brake Line Set, Power Drum, 7pc. - Catalina - Steel (RE).....	155.00/set
PR740MS	1961	Complete Brake Line Set, Power Drum, 7pc. - Catalina - Stainless Steel (RE)	187.00/set
PR740S	1962-64	Complete Brake Line Set, Standard Drum, 7pc. - Cat/GP - Steel (RE).....	155.00/set
PR740SS	1962-64	Complete Brake Line Set, Standard Drum, 7pc. - Cat/GP - Stainless Steel (RE).....	187.00/set
PR740V	1962-64	Complete Brake Line Set, Power Drum, 7pc. - Cat/GP - Steel (RE).....	155.00/set
PR740VS	1962-64	Complete Brake Line Set, Power Drum, 7pc. - Cat/GP - Stainless Steel (RE)	187.00/set
PR740X	1962-64	Complete Brake Line Set, Standard Drum, 7pc. - Bonneville -Steel (RE)	155.00/set
PR740XS	1962-64	Complete Brake Line Set, Standard Drum, 7pc. - Bonneville -Stainless Steel (RE) ...	187.00/set
PR740Z	1962-64	Complete Brake Line Set, Power Drum, 7pc. - Bonneville -Steel (RE).....	155.00/set
PR740ZS	1962-64	Complete Brake Line Set, Power Drum, 7pc. - Bonneville -Stainless Steel (RE) ...	187.00/set
PR741A	1965-66	Complete Brake Line Set, Standard Drum, 7pc. - Cat/GP -Steel (RE)	145.00/ea.
PR741AS	1965-66	Complete Brake Line Set, Standard Drum, 7Pc. - Cat/GP -Stainless Steel (RE)	175.00/ea.
PR741B	1965-66	Complete Brake Line Set,Power Drum, 7Pc. - Cat/GP -Steel (RE)	145.00/ea.
PR741BS	1965-66	Complete Brake Line Set, Power Drum, 7Pc. - Cat/GP - Stainless Steel (RE)	175.00/ea.

PR741D	1965-66	Complete Brake Line Set, Standard Drum, 7Pc. - Bonneville- Steel (RE).....	145.00/ea.
PR741DS	1965-66	Complete Brake Line Set, Standard Drum, 7Pc. - Bonneville-Stainless Steel (RE)	\$175.00/ea.
PR741E	1965-66	Complete Brake Line Set, Power Drum, 7Pc. - Bonneville- Steel (RE).....	145.00/ea.
PR741ES	1965-66	Complete Brake Line Set, Power Drum, 7Pc. - Bonneville -Stainless Steel (RE) ...	175.00/ea.
PR742D	1967-68	Complete Brake Line Set, Standard Drum, 7pc. - Cat/GP - Steel (RE).....	155.00/set
PR742DS	1967-68	Complete Brake Line Set, Standard Drum, 7pc. - Cat/GP - Stainless Steel (RE)	187.00/set
PR742J	1967-68	Complete Brake Line Set, Power Drum, 7pc. - Cat/GP - Steel (RE).....	155.00/set
PR742JS	1967-68	Complete Brake Line Set, Power Drum 7pc. - Cat/GP - Stainless Steel (RE).....	187.00/set
PR742L	1967-68	Complete Brake Line Set, Power Disc, 8pc. - Cat/GP - Steel (RE).....	155.00/set
PR742LS	1967-68	Complete Brake Line Set, Power Disc, 8pc. - Cat/GP - Stainless Steel (RE)	187.00/set
PR743J	1969	Complete Brake Line Set, Power Drum, 7pc. - GP - Steel (RE).....	155.00/set
PR743JS	1969	Complete Brake Line Set, Power Drum, 7pc. - GP - Stainless Steel (RE)	187.00/set
PR743L	1969	Complete Brake Line Set, Power Disc, 8pc. - GP - Steel (RE).....	155.00/set
PR743LS	1969	Complete Brake Line Set, Power Disc, 8pc. - GP - Stainless Steel (RE)	187.00/set
PR744J	1970	Complete Brake Line Set, Power Drum, 8pc. - GP - Steel (RE).....	155.00/set
PR744JS	1970	Complete Brake Line Set, Power Drum, 8pc. - GP - Stainless Steel (RE)	187.00/set
PR744L	1970	Complete Brake Line Set, Power Disc, 9pc. - GP - Steel (RE).....	155.00/set
PR744LS	1970	Complete Brake Line Set, Power Disc, 9pc. - GP - Stainless Steel (RE)	187.00/set
PR745J	1971-72	Complete Brake Line Set, Power Disc, 9pc. - GP - Steel (RE).....	155.00/set
PR745JS	1971-72	Complete Brake Line Set, Power Disc, 9pc. - GP - Stainless Steel (RE)	187.00/set
PR746J	1973-77	Complete Brake Line Set, Power Disc, 7pc. - GP - Steel (RE).....	155.00/set
PR746JS	1973-77	Complete Brake Line Set, Power Disc, 7pc. - GP - Stainless Steel (RE)	187.00/set

Note: Brake lines require pre-payment and are drop-shipped directly from the manufacturer. Please allow 2-3 weeks for delivery.

Comment: All fittings, flares, armor, etc. are excellent. Sets do not include rubber flex hoses or clips.

FLEX HOSES U.S. CARS

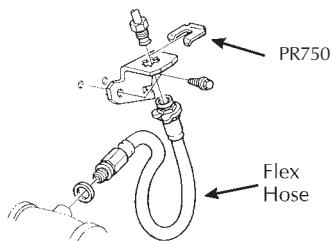

PR750	1960-72	Flex Hose Retaining Clip, Front or Rear (RE).....	1.50/ea.
PR750J	1960	Front Flex Hose, Drum Brakes (2 required) (RE)	25.00/ea.
PR750L	1961-64	Front Flex Hose, Drum Brakes (2 required) (RE)	25.00/ea.
PR750N	1965	Front Flex Hose, Drum Brakes (2 required) (RE)	25.00/ea.
PR750R	1966-68	Front Flex Hose, Drum Brakes (2 required) (RE)	20.00/ea.

PR750T	1967-68	Front Flex Hose, Disc Brakes (2 required) (RE)	\$33.00/ea.
PR750W	1969-70	Front Flex Hose, Drum Brakes - FS (2 required) (RE)	33.00/ea.
PR750Y	1969-70	Front Flex Hose, Disc Brakes - FS (2 required) (RE)	25.00/ea.
PR751B	1969-70	Front Flex Hose, Drum Brakes - GP (2 required) (RE)	25.00/ea.
PR751D	1969-71	Front Flex Hose, Disc Brakes - GP (2 required) (RE)	25.00/ea.
PR751F	1972	Front Flex Hose, Disc Brakes - GP (2 required) (RE)	30.00/ea.
PR753J	1960	Rear Flex Hose (RE)	25.00/ea.
PR753L	1961-64	Rear Flex Hose (RE)	25.00/ea.
PR753N	1965	Rear Flex Hose (RE)	Inquire
PR753R	1966-68	Rear Flex Hose (RE)	Inquire
PR754B	1969-70	Rear Flex Hose - GP (RE).....	25.00/ea.

FLEX HOSES CANADIAN CARS

PR758	1960-68	Canadian Front Flex Hose, Drum Brakes (2 required) (RE)	25.00/ea.
PR758D	1960-63	Canadian Rear Flex Hose (RE).....	25.00/ea.
PR758F	1964	Canadian Rear Flex Hose (RE).....	25.00/ea.
PR758H	1965	Canadian Rear Flex Hose (RE).....	36.00/ea.
PR758K	1966	Canadian Rear Flex Hose (RE).....	36.00/ea.
PR758M	1967-68	Canadian Rear Flex Hose (RE).....	36.00/ea.

JUNCTION BLOCKS & BRACKETS



PR780

PR775A	1969	Brake Distribution Block w/ Bracket - GP (RE)	99.00/ea.
PR775AC	1970	Brake Distribution Block w/ Bracket - GP (RE)	99.00/ea.
PR780	1969-72	Rear Brake Hose Bracket - GP (RE)	29.00/ea.

BRAKE HARDWARE KITS & ADJUSTERS (FULL SIZE)



PR470B
FRONT

PR470B	1955-62	Front Drum Brake Hold Down Kit - All FS (RP)	8.00/kit
PR470D	1965-70	Front Drum Hardware Kit - All FS (RP)	13.00/kit
REAR			
PR470F	1955-57	Rear Brake Hold Down Kit - All FS (RP)	7.50/kit
PR470G	1958	Rear Brake Hold Down Kit - All FS (RP)	8.00/kit
PR470H	1959-62	Rear Brake Hold Down Kit - All FS (RP)	41.00/kit
PR470J	1965-70	Rear Brake Hardware Kit - All FS (RP) ...	16.00/kit
PR470K	1971-75	Rear Brake Hardware Kit - All FS (RP) ...	13.00/kit
PR470L	1976-77	Rear Brake Hardware Kit - All FS w/ 11" x 2" Rear Brake (RP)	13.00/kit



PR472H
REAR

PR472D	1963-70	Rear Brake Adjuster Kit, LH - All FS (RP)	Disc.
PR472E	1963-70	Rear Brake Adjuster Kit, RH - All FS (RP)	Disc.
PR472F	1971-76	Rear Brake Adjuster Kit, LH - All FS w/ 11" x 2" Rear Brake (RP)	\$21.00/kit
PR472G	1971-76	Rear Brake Adjuster Kit, RH - All FS w/ 11" x 2" Rear Brake (RP)	21.00/kit
PR472H	1977	Rear Brake Adjuster Kit, LH - All FS w/ 11" x 2" Rear Brake (RP)	16.00/kit
PR472J	1977	Rear Brake Adjuster Kit, RH - All FS w/ 11" x 2" Rear Brake (RP)	16.00/kit



PR476K
REAR

PR476J	1969-75	Rear Brake Adjuster Kit, LH - GP (RP)	\$16.00/kit
PR476K	1969-75	Rear Brake Adjuster Kit, RH - GP (RP)	16.00/kit
PR476L	1976	Rear Brake Adjuster Kit, LH - GP (RP)	21.00/kit
PR476M	1976	Rear Brake Adjuster Kit, RH - GP (RP)	21.00/kit
PR476N	1977	Rear Brake Adjuster Kit, LH - GP (RP)	16.00/kit
PR476P	1977	Rear Brake Adjuster Kit, RH - GP (RP)	16.00/kit
PR476TN	1969-75	Drum Brake Shoe Guide - GP (RE)	2.00/ea.



PR473D

FRONT

PR473B	1955-62	Front Brake Adjuster, LH or RH - All FS (RP)	11.00/ea.
PR473C	1963-70	Front Brake Adjuster, LH - All FS (RP)	14.00/ea.
PR473D	1963-70	Front Brake Adjuster, RH - All FS (RP)	14.00/ea.

REAR

PR473J	1955-62	Rear Brake Adjuster, LH or RH - All FS (RP)	11.00/ea.
PR473L	1963-70	Rear Brake Adjuster, LH - All FS (RP)	14.00/ea.
PR473M	1963-70	Rear Brake Adjuster, RH - All FS (RP)	14.00/ea.
PR473N	1971-76	Rear Brake Adjuster, LH - All FS w/ 11" x 2" Rear Brake (RP)	11.00/ea.
PR473P	1971-76	Rear Brake Adjuster, RH - All FS w/ 11" x 2" Rear Brake (RP)	11.00/ea.
PR473S	1977	Rear Brake Adjuster, LH - All FS w/ 11" x 2" Rear Brake (RP)	14.00/ea.
PR473T	1977	Rear Brake Adjuster, RH - All FS w/ 11" x 2" Rear Brake (RP)	14.00/ea.



PR477P

FRONT

PR477B	1969-70	Front Brake Adjuster, LH - GP (RP)	11.00/ea.
PR477C	1969-70	Front Brake Adjuster, RH - GP (RP)	11.00/ea.

REAR

PR477J	1969-72	Rear Brake Adjuster, LH - GP (RP)	11.00/ea.
Note: Also fits 1973-75 GP with 9 1/2" x 2" Rear Brakes.			
PR477K	1969-72	Rear Brake Adjuster, RH - GP (RP)	11.00/ea.
Note: Also fits 1973-75 GP with 9 1/2" x 2" Rear Brakes.			
PR477L	1973-76	Rear Brake Adjuster, LH - GP w/ 11" x 2" Rear Brakes (RP)	11.00/ea.
PR477M	1973-76	Rear Brake Adjuster, RH - GP w/ 11" x 2" Rear Brakes (RP)	11.00/ea.
PR477N	1977	Rear Brake Adjuster, LH - GP (RP)	14.00/ea.
PR477P	1977	Rear Brake Adjuster, RH - GP (RP)	14.00/ea.
PR478	1955-77	Brake Adjusting Plug (AP)	.75/ea.

BRAKE DRUMS & SHOES (FULL SIZE)



PR448
FRONT

PR447T	1955-58	Front Brake Drum (RE)	115.00/ea.
PR447W	1959-64	Front Brake Drum, w/ Cooling Fins, Exc. 8-Lug 11x 2 1/2" (RE)	99.00/ea.
PR448	1965-70	Front Brake Drum- All FS w/ 11x 2 1/2" Exc. Heavy Duty & 8-Lug (RP)	109.00/ea.

Note: Full Cast Iron Drum.

PR448J	1955-58	Front Brake Shoes - All w/ Heavy Duty Chassis 12" x 2 1/4" Exc. 1958 Bonneville (RP)	33.00/set
PR448K	1958	Front Brake Shoes - All Bonneville w/ Heavy Duty Chassis 12" x 2 1/2" (RP)	29.00/set



PR475B

FRONT

PR475B	1969-70	Front Drum Brake Hardware Kit - GP (RP)	14.00/kit
PR475C	1969-75	Rear Brake Hardware Kit - GP exc. 1969 w/ 11" x 2" Rear Drum (RP)	14.00/kit
PR475D	1976	Rear Brake Hardware Kit - GP (RP)	13.00/kit
PR475E	1977	Rear Brake Hardware Kit - GP (RP)	13.00/kit

REAR

BRAKE HARDWARE KITS & ADJUSTERS (1969-77 GRAND PRIX)



PR448L

- PR448L 1959-64 Front Brake Shoes - All FS w/ 11x 2 1/2" (RP) \$50.00/set
- PR448M 1965-70 Front Brake Shoes - All FS w/11x 2 1/2" (RP) 50.00/set

REAR

- PR448T 1955-57 Rear Brake Drum (RE)..... 110.00/ea.
- PR448V 1958 Rear Brake Drum (RE)..... Inquire
- PR448W 1959-Early 64 Rear Brake Drum - All w/11x 2 1/2" Exc. 8-Lug (RE)..... 115.00/ea.
- PR449B Late1964-70 Rear Brake Drum - All FS w/ 11x 2 1/2" (RP) 103.00/ea.
- PR449C 1971-77 Rear Brake Drum - All FS w/ 11" x 2" Rear Brake (RP) 51.00/ea.
- PR449J 1955-58 Rear Brake Shoes - All exc. Heavy Duty (RP) 46.00/set

Add \$7.00 oversize fee to standard shipping for each brake drum or rotor.



- PR449K 1955-58 Rear Brake Shoes - All Heavy Duty w/11x 1 3/4" exc. Bonneville (RP) 46.00/set
- PR449L 1959-64 Rear Brake Shoes - All (RP)..... 46.00/set
- PR449M 1965-70 Rear Brake Shoes - All FS (RP) 46.00/set
- PR449N 1971-76 Rear Brake Shoes - All FS w/ 11" x 2" Rear Brake (RP) 27.00/set
- PR449P 1977 Rear Brake Shoes - All FS w/ 11" x 2" Rear Brake (RP) 24.00/set

BRAKE DRUMS & SHOES (1969-77 GRAND PRIX)

FRONT

- PR450A 1969-70 Front Brake Drum, LH or RH - All GP w/ 2 3/4" Hub Hole, Exc. 1969 w/ 11" x 2" Rear Drum (RP) 130.00/ea.
- PR450B 1969-70 Front Brake Shoes - All GP, Exc. 1969 w/ 11" x 2" Rear Drum (RP) 35.00/set

REAR

- PR450J 1969-72 Rear Brake Drum, LH or RH - GP, Exc. 1969 w/ 11" x 2" Rear Drum (RP) .. 69.00/ea.
- PR450K 1973-75 Rear Brake Drum, LH or RH- GP (RP) ... 48.00/ea.
- PR450L 1976-77 Rear Brake Drum, LH or RH- GP (RP) ... 48.00/ea.
- PR450P 1969-75 Rear Brake Shoes - GP, Exc. 1969 w/ 11" x 2" Rear Drum (RP) 32.00/set
- PR450S 1976 Rear Brake Shoes - GP (RP) 27.00/set
- PR450T 1977 Rear Brake Shoes - GP (RP) 24.00/set

Add \$7.00 oversize fee to standard shipping for each brake drum.



BRAKE ROTORS & PADS (FULL SIZE)



PR445J

PR445S

- PR445J 1971-76 Disc Brake Rotor, LH or RH- All FS (RP) 72.00/ea.
- PR445L 1977 Disc Brake Rotor, LH or RH- All FS w/ 11" x 2" Rear Drum (RP) 82.00/ea.
- PR445N 1977 Disc Brake Rotor, LH or RH - All FS w/ 9 1/2" x 2" Rear Drum (RP)..... 72.00/ea.

- PR445S 1967-68 Disc Brake Pads - 4 pcs. (RP)..... \$26.00/set
- PR445T 1969-77 Disc Brake Pads - All FS, 4 pcs. (RP) 29.00/set
- PR445TC 1969-77 Ceramic Disc Brake Pads-All FS,4 pcs.(RP) 45.00/set

BRAKE ROTORS & PADS (1969-77 GRAND PRIX)

- PR446D 1969-72 Disc Brake Rotor, LH or RH- All GP exc. 1969 11" x 2" Rear Drum (RP) 72.00/ea.
- PR446F 1973-77 Disc Brake Rotor, LH or RH- All GP (RP) 79.00/ea.
- PR446H 1969-75 Disc Brake Pads - All GP exc. 1969 11" x 2" Rear Drum, 4 pcs. (RP) 29.00/set
- PR446J 1976-77 Disc Brake Pads - All GP w/ Power Disc, 4 pcs. (RP)..... 20.00/set

Add \$7.00 oversize fee to standard shipping for each brake rotor.



BACKING PLATES & GASKETS



PR440B

- PR440B 1969-72 Front Disc Backing Plate - GP (RE)..... 69.00/pr.
- PR440L 1971-76 Front Disc Brake Backing Plate, LH - FS (GM) 20.00/ea.
- PR440R 1971-76 Front Disc Brake Backing Plate, RH - FS (GM) 20.00/ea.
- PR440L 1973-77 Front Disc Brake Backing Plate, LH - GP (GM) 20.00/ea.
- PR440R 1973-77 Front Disc Brake Backing Plate, RH - GP (GM) 20.00/ea.



PR441CL

- PR441CL 1970-77 Rear Drum Brake Backing Plate, LH - GP w/ 9 1/2" Brakes (RE)..... 49.00/ea.
- PR441CR 1970-77 Rear Drum Brake Backing Plate, RH - GP w/ 9 1/2" Brakes (RE)..... 49.00/ea.



PR442J

PR442JK

PR220

- PR442J 1959-64 Rear Brake Backing Plate to Axle Housing Gasket - FS (RE) 6.50/pr.
- PR442JK 1959-64 Rear Wheel Bearing Retainer to Brake Backing Plate Gasket - FS (RE)..... 6.50/pr.
- PR442JT 1969-72 Axle Flange Gasket - GP (RP) 2.50/ea.

Note: Sold individually; two required per axle.

- PR220 1955-77 Brake Adjusting Plug (AP)75/ea.

WHEEL CYLINDERS (FULL SIZE)



PR460E



PR461C

FRONT

PR460A	1955-57 Front Wheel Cylinder, LH - All FS (RP)..	\$47.00/ea.
PR460B	1955-57 Front Wheel Cylinder, RH - All FS (RP) .	47.00/ea.
PR460C	1958 Front Wheel Cylinder, LH - All FS (RP)..	41.00/ea.
PR460D	1958 Front Wheel Cylinder, RH - All FS (RP) .	41.00/ea.
PR460E	1959-64 Front Wheel Cylinder, LH - All FS (RP)..	41.00/ea.
PR460F	1959-64 Front Wheel Cylinder, RH - All FS (RP) .	41.00/ea.
PR460G	1965-Early '67 Front Wheel Cylinder, LH - All FS (RP)..	32.00/ea.
PR460H	1965-Early '67 Front Wheel Cylinder, RH - All FS (RP) .	32.00/ea.

Note: Early 1967 models used a wheel cylinder with a 1 3/16" bore.

PR460J	Late 1967-70 Front Wheel Cylinder, LH - All FS (RP)..	32.00/ea.
PR460K	Late 1967-70 Front Wheel Cylinder, RH - All FS (RP) .	32.00/ea.

Note: Late 1967 models used a wheel cylinder with a 1 1/8" bore.

REAR

PR461A	1955-57 Rear Wheel Cylinder, LH - All FS (RP)...	19.00/ea.
PR461B	1955-57 Rear Wheel Cylinder, RH - All FS (RP) ..	19.00/ea.
PR461C	1958-64 Rear Wheel Cylinder, LH - All FS (RP)...	29.00/ea.
PR461D	1958-64 Rear Wheel Cylinder, RH - All FS (RP) ..	29.00/ea.
PR461E	1965-77 Rear Wheel Cylinder, LH or RH - All FS w/ 11" x 2" Rear Brakes exc.1976 (RP)	22.00/ea.
PR461F	1976 Rear Wheel Cylinder, LH or RH - All FS w/ 11" x 2" Rear Brakes (RP)	30.00/ea.
PR466R	1969-74 Wheel Cylinder Push Rod Pin,-GP (RE)	4.00/ea.

WHEEL CYLINDERS (1969-77 GRAND PRIX)



PR462E



PR462J

FRONT

PR462C	1969-70 Front Wheel Cylinder, LH - GP (exc. 11" x 2" Rear Drum) (RP)	40.00/ea.
PR462D	1969-70 Front Wheel Cylinder, RH - GP (exc. 11" x 2" Rear Drum) (RP)	39.00/ea.
PR462E	1969 Front Wheel Cylinder, LH - GP (exc. 9 1/2" x 2" Rear Drum) (RP).....	32.00/ea.
PR462F	1969 Front Wheel Cylinder, RH - GP (exc. 9 1/2" x 2" Rear Drum) (RP).....	32.00/ea.

REAR

PR462J	1969 Rear Wheel Cylinder, LH or RH - GP (exc. 9 1/2" x 2" Rear Drum) (RP)	22.00/ea.
PR462K	1969-75 Rear Wheel Cylinder, LH or RH - GP (exc. 1969 11" x 2" Rear Drum)(RP)	28.00/ea.
PR462L	1976-77 Rear Wheel Cylinder, LH or RH - GP (RP).....	22.00/ea.



PR462PB

PR462PB	1965-77 Wheel Cylinder Bolts (4-Pieces) (RE)	4.50/set
----------------	---	----------

WHEEL CYLINDER OVERHAUL KIT (FULL SIZE)



PR465D

FRONT

PR465B	1955-57 Front Wheel Cylinder Overhaul Kit, LH or RH - All FS (RP).....	\$11.00/kit
PR465C	1958 Front Wheel Cylinder Overhaul Kit, LH or RH - All FS (RP).....	11.00/kit
PR465D	1959-64 Front Wheel Cylinder Overhaul Kit, LH or RH - All FS (RP).....	11.00/kit
PR465E	1965-Early '67 Front Wheel Cylinder Overhaul Kit, LH or RH - All FS (RP).....	13.00/kit

Note: Early 1967 models use a cylinder with a 1 3/16" bore. Please measure originals before ordering.

PR465F	Late 1967-70 Front Wheel Cylinder Overhaul Kit, LH or RH - All FS (RP).....	13.00/kit
---------------	---	-----------

Note: Late 1967 models use a cylinder with a 1 1/8" bore. Please measure originals before ordering.

REAR

PR465J	1955-57 Rear Wheel Cylinder Overhaul Kit, LH or RH - All FS (RP).....	11.00/kit
PR465K	1958-64 Rear Wheel Cylinder Overhaul Kit, LH or RH - All FS (RP).....	11.00/kit
PR465L	1965-75 Rear Wheel Cylinder Overhaul Kit, LH or RH - All FS w/ 11" x 2" Rear Brakes (RP)	11.00/kit

Note: Also fits 1977 with 11" x 2" rear brakes.

PR465M	1976 Rear Wheel Cylinder Overhaul Kit, LH or RH - All FS w/ 11" x 2" Rear Brakes (RP)	11.00/kit
---------------	---	-----------

WHEEL CYLINDER OVERHAUL KITS (1969-77 GRAND PRIX)



PR466B

FRONT

PR466B	1969-70 Front Wheel Cylinder Overhaul Kit - GP (RP).....	11.00/kit
---------------	---	-----------

REAR

PR466C	1969 Rear Wheel Cylinder Overhaul Kit - GP Exc. 9 1/2" x 2" Rear Drum (RP)....	11.00/kit
PR466D	1969-75 Rear Wheel Cylinder Overhaul Kit - GP Exc. 1969 w/11" x 2" Rear Drum (RP)	11.00/kit
PR466E	1976-77 Rear Wheel Cylinder Overhaul Kit - GP (RP).....	11.00/kit

DISC BRAKE SPINDLE COMPONENTS



PR438



PR439K



PR439M

PR438 1969-72 Disc Brake Spindle, LH or RH - GP (RE) \$112.00/ea.

PR439K 1969-72 Spindle Bolt, w/Disc Brakes, LH or RH - GP (RE)..... 6.50/ea.

PR439M 1967-72 Steering Arm to Spindle Lock Nut (RE).. 1.00/ea.

Helps secure the caliper bracket and backing plate to the spindle. Two required per spindle.



PR456B



PR456BA

PR456B 1969-77 Disc Brake Caliper Banjo Bolt (RE)..... \$5.00/ea.

PR456BA 1969-77 Copper Brake Hose Washer (RE)..... 1.00/ea.

CALIPER MOUNTING BRACKETS



PR457K

PR457K 1969-72 Caliper Mounting Brackets- GP (RE)..... 79.00/pr.

CALIPERS, KITS & PISTONS (FULL SIZE)

Note: Some calipers require a refundable core charge. Please inquire when ordering.



PR453J



PR452C

PR452A 1967-68 Four Piston Caliper, LH (RP)..... Inquire

PR452B 1967-68 Four Piston Caliper, RH (RP)..... Inquire

PR452C 1969-70 Brake Caliper, LH - All FS (RP)..... 36.00/ea.

PR452D 1969-70 Brake Caliper, RH - All FS (RP)..... 36.00/ea.

PR452E 1971-76 Brake Caliper, LH - All FS (RP)..... 36.00/ea.

PR452F 1971-76 Brake Caliper, RH - All FS (RP)..... 36.00/ea.

PR452G 1977 Brake Caliper, LH - All FS (RP)..... 36.00/ea.

PR452H 1977 Brake Caliper, RH - All FS (RP)..... 36.00/ea.

Note: PR452C - PR452H are remanufactured calipers.

PR453B 1967-68 Caliper Overhaul Kit - All FS (RP)..... 28.00/ea.

PR453D 1969-77 Caliper Overhaul Kit - All FS (RP)..... 15.00/ea.

Note: 1 kit per caliper.

PR453J 1967-68 Brake Caliper Piston - All FS (RP)..... 19.00/ea.

PR453K 1969-77 Brake Caliper Piston - All FS (RP)..... Disc.

CALIPERS, KITS & PISTONS (1969-77 GRAND PRIX)

PR454A 1969-72 Disc Brake Caliper, LH - All GP (RP).... 36.00/ea.

PR454B 1969-72 Disc Brake Caliper, RH - All GP (RP).... 36.00/ea.

Note: PR454A -PR454F are remanufactured calipers.

PR454A and PR454B require a \$25.00 core charge.

PR454C 1973-76 Disc Brake Caliper, LH - All GP (RP)..... 29.00/ea.

PR454D 1973-76 Disc Brake Caliper, RH - All GP (RP).... 29.00/ea.

PR454E 1977 Disc Brake Caliper, LH - All GP (RP)..... 29.00/ea.

PR454F 1977 Disc Brake Caliper, RH - All GP (RP).... 29.00/ea.

PR454C through PR454F require a \$10.00 core charge.

PR455A 1969-77 Caliper Overhaul Kit - All GP, Exc. 1969 11" x 2" Rear Drum (RP)..... 16.00/kit

PR455B 1969-77 Caliper Overhaul Kit - All GP, Exc. 1969 9 1/2" x 2" Rear Drum (RP)..... 28.00/kit

Note: 1 kit per caliper.

PR455J 1969-77 Caliper Piston - All GP, Exc. 1969 11" x 2" Rear Drum (RP)..... Disc.

SPEED BLEEDERS

Bleeding your brakes has never been easier. Revolutionary Russell speed bleeder replaces the original bleeder screw in your wheel cylinder or caliper with a spring-loaded one way ball and check valve design. The unique stainless steel check ball opens to allow fluid and air out, then closes automatically between pumps preventing air from re-entering. Brake bleeding is now a one-person job with the speed bleeder.



PR463A 1955-64 Brake Speed Bleeder - All w/Front & Rear Drums (AP)..... 13.00/pr.

PR463B 1969-77 Front Brake Speed Bleeder - All w/Front Disc (AP)..... 13.00/pr.

PR463C 1965-77 Brake Speed Bleeder - All w/Front & Rear Drums (AP)..... 13.00/pr.

DISC BRAKE SPINDLE KIT



PR207C

PR207C 1959-64 Disc Brake Spindle Kit (AP)..... 469.00/kit

PR207D 1965-66 Disc Brake Spindle Kit (AP)..... 469.00/kit

PR207E 1967-68 Disc Brake Spindle Kit (AP)..... 469.00/kit

This kit allows you to use existing drum brake spindles and convert to front disc brakes. In addition to this kit you will need to supply a proportioning valve, master cylinder, booster and hard lines.

Add \$20.00 oversize fee to standard shipping for spindle kits.



SSBC

PERFORMANCE BRAKE SYSTEMS

- PR438BB** 1969 -72 "Short Stop" Power Disc Brake Rotor and Pad Kit (AP) \$295.00/kit
 PR438BB Notes: Slotted, plated and vented rotors to prevent warpage and corrosion. High Performance pads. Fits original spindles, calipers and wheels. This is a direct bolt in.
- PR438FA** 1973-77 "Short Stop" Power Disc Brake Rotor and Pad Kit (AP) 229.00/kit
 PR438FA Notes: Slotted, plated and vented rotors to prevent warpage and corrosion. High Performance pads. Fits original spindles, calipers and wheels. This is a direct bolt in.
- PR438FB** 1973-77 "Quick Change" Clear Billet Caliper and Pad Upgrade Kit 495.00/kit
 PR438FB Notes: Must use minimum 15" wheel. Honey combs and Snowflake rims will not work. Includes clear anodized, loaded 2-piston calipers with high performance pads.
- PR438FBC** 1973-77 "Quick Change" Colored Billet Caliper and Pad Upgrade Kit 620.00/kit
 PR438FBC Notes: Must use minimum 15" wheel. Honey combs and Snowflake rims will not work. Includes color powder coated, loaded, 2-piston calipers with high performance pads. Colors: Black, blue, red, yellow, silver and orange. For polished calipers add \$50.00 to the kit.

Add \$20.00 oversize fee to standard shipping for "Short Stop & Quick Change" kits.

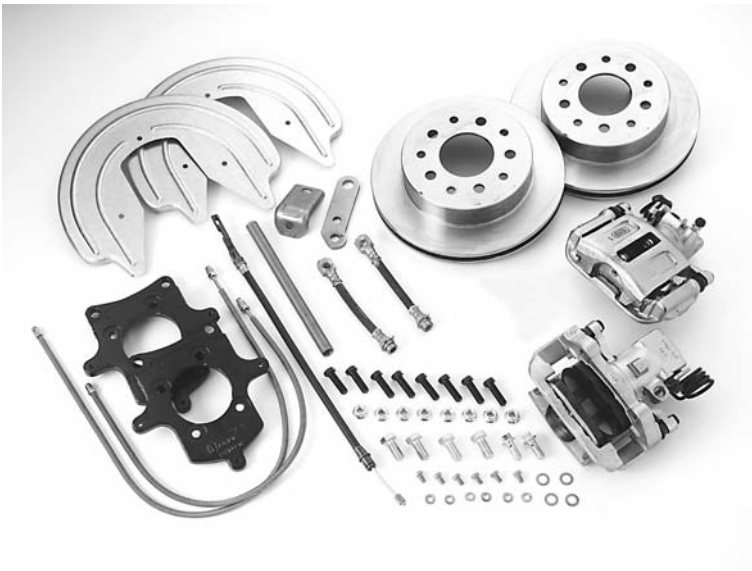

REAR DISC CONVERSION KITS

- PR438KB** 1973-77 Rear Disc Brake Conversion Kit, Cast Iron Calipers, Non Staggered (AP) \$795.00/kit
- PR438KBC** 1973-77 Rear Disc Brake Conversion Kit, Colored Cast Iron Calipers, Non Staggered (AP) 920.00/kit
 PR438KB Notes: Can be used with minimum 14" X 7" wheels. Not for use with staggered shock or "C" clip 10 and 12 bolt rear ends. Will not work with "C" clip eliminators. Comes with loaded single piston calipers with built in parking brake. 10.5" rotors. For slotted and plated rotors, add \$33.00 per rotor. For drilled, slotted and plated rotors, add \$66.00 per rotor.
- FR223AC Notes: Colors available; Black, blue, red, yellow, silver and orange.
- PR438RB** 1973-77 Rear Disc Brake Conversion Kit, Clear Anodized Calipers (AP) 1195.00/kit
- PR438RBC** 1973-77 Rear Disc Brake Conversion Kit, Colored Aluminum Calipers (AP) 1420.00/kit
 PR438RB Notes: Not for use with staggered shock or "C" clip 10 and 12 bolt rear ends. Will not work with "C" clip eliminators. Comes with loaded billet aluminum single piston calipers with built in parking brake. 11.25" rotors. For drilled rotors, add \$66.00.
- PR438RBC Notes: Caliper colors available; Black, blue, red, yellow, silver and orange. Polished aluminum add \$50.00.

Add \$50.00 oversize fee to standard shipping for disc conversions



TRANS, CLUTCH, BRAKE

GREASE CAPS



PR602

PR600	1955-61 Front Hub Grease Cap (AP)	Inquire
PR602	1962-70 Front Hub Grease Cap - All (GM)	\$13.50/ea.
PR602	1971-72 Front Hub Grease Cap - GP (GM)	13.50/ea.
PR604	1971-76 Front Hub Grease Cap - FS (AP)	7.00/ea.
PR604	1973-77 Front Hub Grease Cap - GP (AP)	7.00/ea.
PR604N	1962-77 Front Spindle Nut & Washer Kit, All (GM)	5.00/ea.

WHEEL BEARINGS & SEALS (1955-1976 FS)



PR612H



PR627

PR612	1955-57 Front Inner Wheel Bearing (RP)	Inquire
PR612D	1958-61 Front Inner Wheel Bearing (RP)	Inquire
PR612H	1962-68 Front Inner Wheel Bearing (RP)	9.00/ea.
PR612M	1969-76 Front Inner Wheel Bearing - FS (RP)	14.00/ea.
PR616	1955-61 Front Outer Wheel Bearing (RP)	49.00/ea.
PR616H	1962-70 Front Outer Wheel Bearing - FS (RP)	10.00/ea.
PR616M	1971-76 Front Outer Wheel Bearing - FS (RP)	13.00/ea.
PR618	1955-57 Front Wheel Seal (RP)	Inquire
PR618D	1958-61 Front Wheel Seal (RP)	Inquire
PR618H	1962-68 Front Wheel Seal (RP)	11.00/ea.
PR618M	1969-70 Front Wheel Seal - FS (RP)	Disc.
PR618R	1971-76 Front Wheel Seal - FS (RP)	4.00/ea.
PR620	1955 Rear Wheel Bearing (RP)	49.00/ea.
PR620D	1956-58 Rear Wheel Bearing (RP)	Inquire
PR620H	1959-64 Rear Wheel Bearing (RP)	49.00/ea.
PR620M	1965-70 Rear Wheel Bearing - FS (RP)	109.00/ea.
PR620R	1971-76 Rear Wheel Bearing - FS w/ B or O Code Axle (RP)	39.00/ea.
PR620T	1971-76 Rear Wheel Bearing - FS w/ G, K, M or P Code Axle (RP)	19.00/ea.
PR622	1955 Rear Wheel Seal (RP)	18.00/ea.
PR622D	1956-58 Rear Wheel Seal (RP)	Inquire
PR622H	1959-64 Rear Wheel Seal (RP)	18.00/ea.
PR622M	1965-70 Rear Wheel Seal, FS (RP)	25.00/ea.
PR622R	1971-76 Rear Wheel Seal - FS w/ B or O Code Axle (RP)	29.00/ea.
PR622T	1971-76 Rear Wheel Seal - FS w/ G, K, M or P Code Axle (RP)	10.00/ea.

WHEEL BEARINGS & SEALS (1969-72 GRAND PRIX)

PR625	1969-77 Front Inner Wheel Bearing w/ Race - GP (RP)	9.00/ea.
PR626	1969-77 Front Outer Wheel Bearing w/ Race - GP (RP)	9.00/ea.
PR627	1969-72 Front Wheel Seal - GP w/ Drum Brakes (RP)	13.00/ea.
PR628	1969-72 Front Wheel Seal - GP w/ Disc Brakes (RP)	3.00/ea.
PR629	1973-77 Front Wheel Seal - GP w/ Disc Brakes (RP)	3.00/ea.

PR630	1969-70 First Design Rear Wheel Bearing - GP w/ 10-Bolt Rear (RP)	\$35.00/ea.
--------------	--	-------------

Note: PR630 replaces 1970 first design rear bearing. Please refer to dimensions below for your application.

OD 2.747" ID 1.375"

PR631	1970 Second Design-1972 Rear Wheel Bearing - GP w/ 10-Bolt Rear (RP)	32.00/ea.
--------------	---	-----------

Note: PR631 replaces 1970 second design rear bearing. Please refer to dimensions below for your application.

OD 2.558" ID 1.375"

PR632	1970-72 Rear Wheel Bearing - GP w/ 12-Bolt Rear (RP)	19.00/ea.
--------------	---	-----------

PR633	1973-77 Rear Wheel Bearing - GP (RP)	17.00/ea.
--------------	--	-----------

PR634	1969-70 First Design Rear Wheel Seal - GP w/ 10-Bolt Rear (RP)	17.00/ea.
--------------	---	-----------

Note: PR634 replaces 1970 first design wheel seal. Please check original bearing dimension before ordering.

PR635	1970-72 Rear Wheel Seal With .490" Width - GP w/ 10-Bolt Rear (RP)	10.00/ea.
--------------	---	-----------

Note: PR635 replaces 1970-72 wheel seal with a width of .490". Please check original width before ordering.

PR636	1970-72 Rear Wheel Seal w/ .375" Width - GP w/ 10-Bolt Rear (RP)	11.00/ea.
--------------	---	-----------

Note: PR636 replaces 1970-72 wheel seal with a width of .375". Please check original width before ordering.

PR637	1970-72 Rear Wheel Seal - GP w/ 12-Bolt Rear (RP)	5.00/ea.
--------------	---	----------

PR638	1973-77 Rear Wheel Seal - GP (RP)	5.00/ea.
--------------	---	----------

UNIVERSAL JOINTS



PR567	1955 U-Joint, Rear Axle End w/ Bolts (AP)	49.00/ea.
--------------	---	-----------

PR569	1956-77 U-Joint - All (AP)	18.00/ea.
--------------	----------------------------------	-----------

The above universal joints are genuine Spicer.

POSI-TRACTION CARRIERS



PR479

PR479	1969-72 8.2" 10-Bolt Posi-Traction Carrier- GP(RP)	589.00/ea.
--------------	--	------------

PR479 is a heavy-duty clutch-style Auburn unit. It is the carrier only and does not include the installation kit (see kit PR482B). For use with 3.36:1 to 4.33:1 gears.

PR479A	1973-77 8.5" 10-Bolt Posi-Traction Carrier (RP) ..	599.00/ea.
---------------	--	------------

PR479A is a heavy-duty clutch-style Auburn unit. It is the carrier only and does not include the installation kit (see kit PR482B). For use with 3.23:1 to 4.33:1 gears.

PR479B	1973-77 12-Bolt Posi-Traction Carrier (RP)	549.00/ea.
---------------	--	------------

PR479B is a heavy-duty clutch-style Auburn unit. It is the carrier only and does not include the installation kit (see kit PR482B). For use with 3.07:1 to 3.73:1 gears.

RING & PINION KITS



- PR480C** 1969-72 10 Bolt Ring & Pinion Kit 3.36:1(AP) \$319.00/kit
- PR480F** 1969-72 10 Bolt Ring & Pinion Kit 3.55:1(AP) 319.00/kit
- PR480K** 1969-72 10 Bolt Ring & Pinion Kit 3.73:1(AP) 319.00/kit
- PR480N** 1969-72 10 Bolt Ring & Pinion Kit 3.90:1(AP) 319.00/kit

These "Yukon™" high-performance ring and pinion kits are made from 8620 steel for long life. 1 year warranty.

REAR END BEARING KITS & GASKETS



PR482B

- PR482** 1957-64 8.4", 10-Bolt Ring Gear Bearing Kit (AP) 147.00/kit
- PR482B** 1969-72 8.2", 10-Bolt Ring Gear Bearing Kit (AP) 119.00/kit
- PR482D** 1970-72 12-Bolt Ring Gear Bearing Kit (AP)..... 125.00/kit
- PR482G** 1971-76 8.5", 10-Bolt Ring Gear Bearing Kit
- FS (AP)..... 124.00/kit
- PR482G** 1973-77 8.5", 10-Bolt Ring Gear Bearing Kit
- GP (AP)..... 124.00/kit

Note: We are unable to supply bearing kits for the FS 10-bolt rears that have 12-bolt ring gears.

DIFFERENTIAL CARRIER WASHERS & NUTS



PR520

- PR520** 1955-64 Copper Differential Carrier Washers & Nuts (RE) 15.00/set

REAR END COMPONENTS



PR525CC

- PR525CC** 1969-72 10 Bolt Rear Chrome Cover w/Gasket- GP (RE)..... 39.00/ea.



PR525CS

- PR525CS** 1969-72 10 Bolt Bare Steel Rear End Cover - GP (RE)39.00/ea.
- PR525CSK** 1969-72 10 Bolt Bare Steel Rear End Cover w/Bolts & Gasket- GP (RE) 47.00/ea.

- PR525D** 1970-72 12 Bolt Bare Steel Rear End Cover - GP (RE) \$42.00/ea.
- PR525DS** 1970-72 12 Bolt Bare Steel Rear End Cover w/Bolts & Gasket- GP (RE) 53.00/ea.

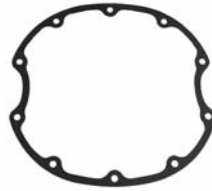

PR525

- PR524C** 1957-64 Rear End Gasket - FS (RP)..... 16.00/ea.

- PR524D** 1965-70 Rear End Gasket - FS (RP)..... Inquire

- PR525** 1969-72 10 Bolt Rear End Cover Gasket - GP (RP) 6.00/ea.

- PR525A** 1970-72 12 Bolt Rear End Cover Gasket - GP (RP) 5.00/ea.

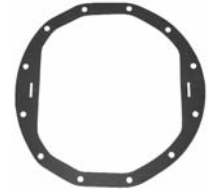

PR525A



PR526

- PR526** 1965-72 10-Bolt Rear End Cover Bolt Kit (RP)..... 5.00/kit

- PR527** 1970-72 12-Bolt Rear End Cover Bolt Kit-GP (RP) 6.00/kit



- PR489J** 1960-66 Safe-T-Track Differential Axle Tag (RE) .. 10.00/ea.
- PR490** Limited Slip Rear Axle Tag (RE)..... 5.50/ea.
- PR491** 1970-72 Limited Slip Rear Axle Tag, All 455ci w/ 12 Bolt Rear - GP (RP) 10.00/ea.

- PR489J** 1960-66 Safe-T-Track Differential Axle Tag (RE) .. 10.00/ea.

- PR490** Limited Slip Rear Axle Tag (RE)..... 5.50/ea.

- PR491** 1970-72 Limited Slip Rear Axle Tag, All 455ci w/ 12 Bolt Rear - GP (RP) 10.00/ea.



PR491J

- PR491J** 1963-77 Rear Axle Vent Tube (RP) 5.00/ea.



PR500

- PR500** Limited Slip Rear Axle Lubricant, 23 oz. (GM)..... 14.00/ea.



PR502

- PR502** Limited Slip Rear Axle Additive, 4 oz. (GM)..... 11.00/ea.

This General Motors additive enhances the operation of your positraction unit and prolongs clutch life.

PR500 must be used in conjunction with PR502 for limited slip rear axles.

It normally takes (4) PR500 and (1) PR502 to fill a rear end.

S U S P E N S I O N

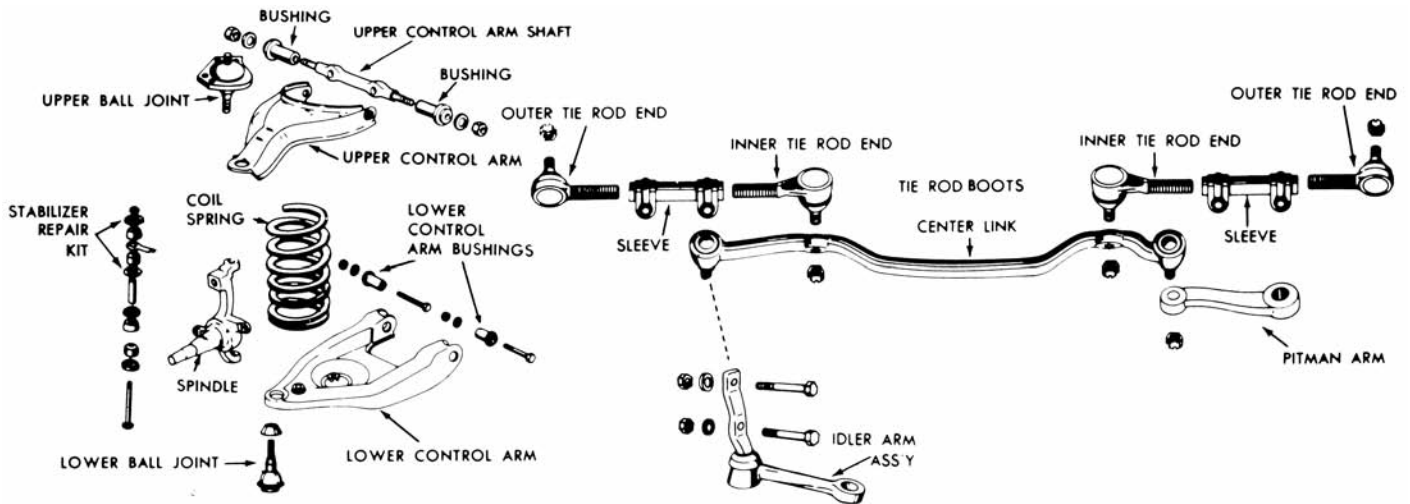

FRONT SUSPENSION



PS102

PS105L

PS100J	1955	King Pin Set (AP)	\$109.00/set
PS100K	1956-57	King Pin Set (AP)	97.00/set
PS100W	1955-57	Lower Ball Joint (AP)	125.00/ea.
PS101	1958-64	Lower Ball Joint (AP)	70.00/ea.
PS101AA	1958-64	Lower Ball Joint Boot - FS (RE)	7.00/ea.
PS102	1966-70	Lower Ball Joint - FS (AP)	75.00/ea.

Note: PS102 also fits 1965 models if they do not have flanged edges on the lower control arm or a plate welded over the ball joint.

PS102AA	1966-70	Lower Ball Joint Boot - FS (RE)	6.00/ea.
PS103	1971-76	Lower Ball Joint - FS (AP)	39.00/ea.
PS104	1969-72	Lower Ball Joint - GP (AP)	33.00/ea.
PS104D	1973-77	Lower Ball Joint - GP (AP)	33.00/ea.
PS104DE	1969-77	"Original-Style" Lower Ball Joint Boot - FS (RE)	3.50/ea.
PS104J	1955-57	Upper Ball Joint (AP)	135.00/ea.
PS104K	1958	Upper Ball Joint (AP)	129.00/ea.
PS104L	1959-63	Upper Ball Joint, LH (AP)	109.00/ea.
PS104M	1959-63	Upper Ball Joint, RH (AP)	105.00/ea.
PS104LM	1959-70	Upper Ball Joint Boot - FS (RP)	7.00/ea.
PS105J	1964-70	Upper Ball Joint, Pair (NORS)	Disc.
PS105L	1964-70	Upper Ball Joint, LH - FS (AP)	75.00/ea.
PS105R	1964-70	Upper Ball Joint, RH - FS (AP)	75.00/ea.
PS106	1971-76	Upper Ball Joint - FS (AP)	33.00/ea.
PS107	1969-72	Upper Ball Joint - GP (AP)	27.00/ea.
PS107D	1973-77	Upper Ball Joint - GP (AP)	33.00/ea.



PS107TH

PS107TA	1955-57	Upper Control Arm Shaft w/Bushings (AP)	125.00/ea.
PS107TC	1958-62	Upper Control Arm Shaft w/Bushings (AP)	155.00/ea.
PS107TF	1963-64	Upper Control Arm Shaft w/Bushings (AP)	Inquire
PS107TH	1965-70	Upper Control Arm Shaft w/Bushings - FS (AP)	79.00/ea.

PS107TK	1969-72	Upper Control Arm Shaft w/Bushings - GP (AP)	\$79.00/ea.
PS108	1971-73	Upper Control Arm Shaft - FS (AP)	49.00/ea.
PS109	1974-76	Upper Control Arm Shaft - FS (AP)	65.00/ea.
PS108	1973	Upper Control Arm Shaft - GP (AP)	49.00/ea.
PS109	1974-77	Upper Control Arm Shaft - GP (AP)	65.00/ea.



PS112SL

PS116SJ

PS112L	1961	Inner Tie Rod, LH (AP)	69.00/ea.
PS112R	1961	Inner Tie Rod, RH (AP)	69.00/ea.
PS112SL	1962-63	Inner Tie Rod, LH (AP)	115.00/ea.
PS112SR	1962-63	Inner Tie Rod, RH (AP)	115.00/ea.
PS112TL	1964	Inner Tie Rod, LH (AP)	115.00/ea.
PS112TR	1964	Inner Tie Rod, RH (AP)	115.00/ea.
PS112L	1965-68	Inner Tie Rod, LH (AP)	69.00/ea.
PS112R	1965-68	Inner Tie Rod, RH (AP)	69.00/ea.
PS112LA	1961-76	Inner Tie Rod Boot (RE)	3.50/ea.
PS113L	1969-70	Inner Tie Rod, LH - FS (AP)	109.00/ea.
PS113R	1969-70	Inner Tie Rod, RH - FS (AP)	109.00/ea.
PS114	1971-76	Inner Tie Rod - FS (AP)	25.00/ea.
PS115	1969-70	Inner Tie Rod - GP (AP)	25.00/ea.
PS115A	1969-77	Inner or Outer Tie Rod Boot - GP (RE)	3.50/ea.
PS116	1971-72	Inner Tie Rod - GP (AP)	60.00/ea.
PS116A	1973-77	Inner Tie Rod - GP (AP)	25.00/ea.
PS116SA	1955-58	Outer Tie Rod (AP)	45.00/ea.
PS116SB	1955-58	Outer Tie Rod Boot - FS (RE)	3.50/ea.
PS116SF	1959-60	Outer Tie Rod, LH (AP)	85.00/ea.
PS116SG	1959-60	Outer Tie Rod, RH (AP)	85.00/ea.
PS116SJ	1961-63	Outer Tie Rod (AP)	55.00/ea.
PS116SJB	1962-64	Inner or Outer Tie Rod Boot - FS (RP)	3.50/ea.
PS116SK	1964	Outer Tie Rod (AP)	95.00/ea.
PS117	1965-70	Outer Tie Rod End - FS (AP)	85.00/ea.
PS117AA	1966-70	Outer Tie Rod Boot - FS (RE)	3.50/ea.
PS118	1971-76	Outer Tie Rod End - FS (AP)	21.00/ea.
PS119	1969-70	Outer Tie Rod End - GP (AP)	59.00/ea.
PS120	1971-72	Outer Tie Rod End - GP (AP)	64.00/ea.
PS120A	1973-77	Outer Tie Rod - GP (AP)	23.00/ea.

S U S P E N S I O N / S T E E R I N G

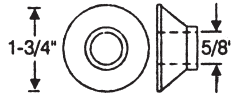

PS120SA

- PS120SA 1955-63 Tie Rod End Dust Boot (RE) \$5.50/ea.
- PS121 1963-70 Center Link - FS (AP)..... 150.00/ea.
- PS123 1969-72 Center Link - GP (AP) 90.00/ea.
- PS123A 1973-76 Center Link - FS (AP)..... 89.00/ea.
- PS123B 1973-77 Center Link - GP (AP) 109.00/ea.



PS123PF

- PS123PA 1955-62 Idler Arm Bracket (AP) 99.00/ea.
- PS123PD 1955-60 Idler Arm (AP) 129.00/ea.
- PS123PF 1961-62 Idler Arm (AP) 109.00/ea.

Note: PS123PD and PS123PF do not include the idler arm bracket.
See PS123PA.

- PS124 1963-70 Steering Idler Arm - FS (AP) 129.00/ea.
- PS125 1971-72 Steering Idler Arm - FS (AP) 32.00/ea.
- PS126 1969-72 Steering Idler Arm - GP (AP)..... 39.00/ea.
- PS126A 1973-74 Steering Idler Arm - All (AP) 39.00/ea.
- PS126B 1975-76 Steering Idler Arm - FS (AP) 39.00/ea.
- PS126C 1975-77 Steering Idler Arm - GP (AP)..... 33.00/ea.
- PS130 1955-76 Tie Rod Adjusting Sleeve - FS (AP)..... 15.00/ea.
- PS130A 1969-70 Tie Rod Adjusting Sleeve - GP (AP)..... 13.00/ea.
- PS130 1971-77 Tie Rod Adjusting Sleeve - GP (AP)..... 15.00/ea.

URETHANE BALL JOINT & TIE ROD BOOTS



PS219

- PS219 1969-77 Urethane Ball Joint Boots, Set of 4 -GP (AP) 8.00/set
- PS219D 1955-77 Urethane Tie Rod Boots, Pair (AP) 5.00/pr.

Requires 2 pairs per car.

RUBBER BUMPERS



PS133

PS136

PS137

PS139

- PS132R 1955-56 Rear Axle to Frame Bumper (Mounts on Spring) (RE) \$41.00/pr
 - PS132T 1958-60 Rear Axle Bumpers, Pair (Double Stud Mount) (RE)..... 20.00/pr.
 - PS133 1965-72 Rear Axle to Frame Bumper - All (RE) ... 6.00/ea.
 - PS133D 1973-76 Rear Axle to Frame Bumper - FS (RE) ... 6.00/ea.
 - PS133F 1965-72 Correct "Ribbed" Rear Axle to Frame Bumper - FS (RE)..... 19.00/ea.
 - PS133G 1973-77 Correct "Ribbed" Rear Axle to Frame Bumper - GP (RE) 19.00/ea. NEW
 - PS133H 1973-77 Rear Axle to Frame Bumper - GP (GM). Disc.
 - PS136 1969-77 Pinion Bumper - GP (GM) 24.00/ea.
 - PS137 1957-70 Upper Control Arm Bumper - FS (GM) . 11.00/ea.
 - PS137 1969-72 Upper Control Arm Bumper - GP (GM) 11.00/ea.
 - PS137A 1957-70 Upper Control Arm Bumper - FS (RE) .. 7.00/ea.
 - PS137A 1969-72 Upper Control Arm Bumper - GP (RE) .. 7.00/ea.
- PS137A is a good alternative to the expensive GM piece.
- PS137D 1973-77 Upper Control Arm Bumper - GP (GM) 4.50/ea.
 - PS137X 1955-57 Lower Control Arm Bumpers (RE) 48.00/pr.
 - PS138 1961-70 Lower Control Arm Bumper - FS (RE).... 12.00/ea.
 - PS139 1969-72 Lower Control Arm Bumper - GP (GM) 10.00/ea.
 - PS139A 1969-72 Lower Control Arm Bumper - GP (RE) .. 7.50/ea.
 - PS140 1971-72 Lower Control Arm Bumper - FS (GM) . 11.00/ea.

FRONT CONTROL ARMS & COMPONENTS



PS160AB

- PS160AA 1970-72 Upper Control Arm, LH - GP (RE)..... 119.00/ea.
- PS160AB 1970-72 Upper Control Arm, RH - GP (RE) 119.00/ea.



PS160FB

- PS160FA 1970-72 Lower Control Arm, LH - GP (RE) 149.00/ea.
- PS160FB 1970-72 Lower Control Arm, RH - GP (RE)..... 149.00/ea.

SUSPENSION/STEERING

Ames Performance
Pontiac Nationals

DON'T MISS THE 2011 Ames Performance TRI-POWER PONTIAC NATIONALS!

THE WORLD'S LARGEST ALL-PONTIAC SHOW AND RACE EVENT

August 2011 - Summit Motorsports Park - Norwalk, OH

For more information contact: Super Duty Promotions
P.O. Box 714 - Norwalk, OH 44857
(419)663-7383

For highlights from past years and information on the 2011 upcoming event, go to:
www.amesperf.com



PS161B

PS161B 1965-76 Upper-A-Frame Shaft Lock Nut Set FS 4PC (AP)..... \$6.00/ea.

PS161D 1965-76 Upper-A-Frame Shaft Lock Nut Set GP 4PC (AP) 6.00/ea.



PS170

PS170 1969-72 Upper A-frame to Frame Bolt Kit- GP (RP) 17.00/kit
Consists of 4 bolts, 4 washers and 4 nuts to attach the front upper A-frame shaft to the frame rail.



PS179

PS179 1965-70 Upper Control Arm Shaft Bushings -FS, Pair (RP) 22.00/pr.

PS180 1969-72 Upper Control Arm Shaft Bushings -GP, Pair (RP) 12.50/pr.

PS181 1971-72 Upper Control Arm Shaft Bushings -FS, Pair (RP) 12.50/pr.



PS182

PS181D 1962-64 Lower Control Arm Bushing Kit (RE)..... Disc.

PS182 1965-70 Lower Control Arm Bushing Kit (RP)..... 32.00/pr.
w/ Oval Rear Bushing- FS (RP) 24.00/pr.

PS182 1969-72 Lower Control Arm Bushing Kit, w/ Oval Rear Bushing- GP (RP) 24.00/pr.

PS179 and PS182 are only available as kits. One kit does one A-frame.

PS184 1971-72 Lower Control Arm Bushing, Front - FS (GM) 17.00/ea.

PS185 1971-72 Lower Control Arm Bushing, Rear (GM) 19.00/ea.



PS185S

PS185S 1969-72 Front Lower A-frame Bolt - GP (RP) 7.00/ea.

PS185T 1969-72 Front Lower A-frame Nut - GP (GM)..... 2.00/ea.



PS185T

These original bolts and nuts (PS185S & PS185T) will ensure the correct markings and contours for your restoration.

URETHANE FRONT CONTROL ARM BUSHINGS



PS220

PS220 1969-72 Front Control Arm Bushings, 8 pcs.-GP(AP) \$60.00/set

Note: Bushings come with outer metal shell, except oval. **Your original oval steel sleeve must be used.**

PS221 1971-73 Front Control Arm Bushings, 8 pcs.-FS(AP) 75.00/set

PS221 1973 Front Control Arm Bushings, 8 pcs.-GP(AP) 75.00/set

PS223 1974-76 Front Control Arm Bushings, 8 pcs.-FS(AP) 75.00/set

PS223 1974-77 Front Control Arm Bushings, 8 pcs.-GP(AP) 75.00/set

Note: Sets contain bushings for 2 upper and 2 lower control arms.

ALIGNMENT SHIMS



PS181F

PS181F 1955-77 1/8" Caster and Camber Shims (AP)25/ea.

PS181H 1955-77 1/16" Caster and Camber Shims (AP)25/ea.

PS181FR 1955-77 Original Style 1/8" Caster and Camber Shims (AP) 2.00/ea.

PS181HR 1955-77 Original Style 1/16" Caster and Camber Shims (AP) 2.00/ea.



PS181FR

POWER STEERING BOX



PS510

PS510 1962-76 Quick Ratio Steering Box - w/Casting #5687962 (RP) 189.00/ea.

PS510A 1962-76 Quick Ratio Steering Box - w/Casting #6 or 76 (RP) 189.00/ea.

Check original casting number prior to ordering. These 2 steering boxes are not interchangeable.

This remanufactured steering box is lock-to-lock 3 turns vs. the originals at 4 turns. Some 1969-72's were equipped with quick ratio boxes originally.

Note 1: PS541 steering coupler must be used in conjunction with these steering boxes for 62-66 applications.

PS510 & PS510A have a \$75.00 refundable core charge. Add \$8.00 oversize fee to standard shipping for power steering boxes.



PS510C 1969-76 Quick Ratio Power Steering Box, 2 1/2 Turn
- GP Only (AP) \$259.00/ea.

PS510C is rebuilt using late-model Chevy Iroc internals resulting in 2 1/2 turns lock-to-lock.

Note: PS541 steering coupler must be used in conjunction with PS510C on 1964-66 applications.

PS510J 1977 Quick Ratio Power Steering Box, 3 Turn
- GP (AP)..... 189.00/ea.

PS510J is 3 turns lock to lock vs. the originals at 4 turns.

Core Note: PS510C and PS510J require a \$75.00 refundable core charge. Cores must be the same style as the new steering box.

Add \$8.00 oversize fee to standard shipping for steering boxes.



MANUAL STEERING BOX

PS510G 1964-69 Manual Steering Box - All (RP) 189.00/ea.

Restore your car's steering to like new with a Saginaw remanufactured unit.

Note 1: You must use the PS539X Steering coupler with the PS510G Box

PS510N 1970-74 Quick Ratio Manual Steering
Box - All (RE)..... 189.00/ea.

PS510N is 6.5 turns lock to lock and approx: 24:1 Ratio, Course Spline.

Core Note: PS510G and PS510N require a \$75.00 refundable core charge. Cores must be the same style as the new steering box.

Add \$8.00 oversize fee to standard shipping for steering boxes.



BOLTS- STEERING BOX



PS515



PS516

PS515 1962-77 Steering Box Bolt (GM) 3.50/ea.

PS516 1962-77 Steering Box Bolt Washer (GM-RP) 2.50/ea.

This washer is a GM replacement. Dimensions are correct; the shape is octagonal instead of round like originals.

POWER STEERING HOSES



PS528F

PS528F 1961-70 Power Steering Return Hose Kit(RP) 16.00/ea.



PS530

PS530 1964-70 Power Steering Hose - All, exc. '69-70 GP (AP) 49.00/ea.

PS532 1969-70 Power Steering Hose - GP (AP) 33.00/ea.

PS534 1971-72 Power Steering Hose - All (AP) 29.00/ea.

PS536 1973-76 Power Steering Hose - All (AP) 33.00/ea.

These after-product hoses do not have the same configuration as originals.

POWER STEERING PUMPS



PS538F

PS538L 1964 Remanufactured Power Steering
Pump w/Reservoir - All w/ V8 (RP)..... \$69.00/ea.

PS538F 1965-66 Remanufactured Power Steering
Pump w/Reservoir, All w/ V8 (RP)..... 69.00/ea.

PS538J 1967-70 Remanufactured Power Steering
Pump w/Reservoir, All w/V8 (RP)..... 69.00/ea.

PS538V 1971-72 Remanufactured Power Steering
Pump w/Reservoir - All V8 (RP) 75.00/ea.

These pumps may not be an identical match to original but work well. You must reuse your original pulley and cap. Paint is not to show quality standards.

Core Note: PS538L through PS538V require a \$50.00 refundable core charge. Cores must be the same style as the new power steering pump.

PS539AA 1964-66 Remanufactured Power Steering
Pump w/o Reservoir - All w/V8 (RP)..... 65.00/ea.

PS539AB 1967-74 Remanufactured Power Steering
Pump w/o Reservoir - All w/V8 (RP)..... 65.00/ea.

PS539AC 1975-77 Remanufactured Power Steering
Pump w/o Reservoir - All V8 (RP)..... 65.00/ea.

PS539AA through PS539AC are remanufactured pumps which do not include the reservoir. Your car's original reservoir must be used.

Core Note: PS539AA through PS539AC require a \$15.00 refundable core charge. Cores must be the same style as the new power steering pump.

POWER STEERING PULLEYS



PS539C

PS539C 1967-69 Power Steering Pulley - All Exc. AC (RE) 69.00/ea.

PS539CA 1967-70 Power Steering Pump Pulley- All w/AC (RE)69.00/ea.

POWER STEERING PUMP CAPS



PS359P

PS539P 1959-63 Power Steering Pump Cap (GM) 16.00/ea.

PS539R 1971-77 Power Steering Pump Cap (GM-RP)..... 11.00/ea.

PS539P & PS539R are GM replacement caps. They may not look like originals.

STEERING COUPLERS



PS539Y



PS545



- | | | |
|---------------|---|-------------|
| PS539X | 1964-66 Steering Column Coupling, w/ Standard Steering (GM) | \$39.00/ea. |
| PS539Y | 1967-69 Steering Column Coupling, w/ Standard Steering (GM) | 109.00/ea. |
| PS540 | 1970-77 Steering Column Coupling, w/ Standard Steering, All (RE)..... | 39.00/ea. |
| PS540J | 1964-66 Steering Column Coupling, w/ Power Steering (RE)..... | 39.00/ea. |
| PS541 | 1967-76 Steering Column Coupling, All w/ Power Steering (GM) | 72.00/ea. |

These are the flange assembly couplings that connect the steering box to the steering column. There are many after-product versions on the market that are less expensive 2-piece designs. We feel that with this product, safety is a major concern. Therefore, factory GM couplings are always our first choice.

- | | | |
|--------------|--|-----------|
| PS545 | 1969-77 Steering Column Lower Bearing Adaptor (RE) | 10.00/ea. |
|--------------|--|-----------|

REAR CONTROL ARMS, BUSHINGS & HARDWARE



PS186

- | | | |
|---------------|---|------------|
| PS186 | 1969-72 Rear Lower Control Arm w/Rubber Bushings, Boxed, Pair - GP (RE)..... | 199.00/pr. |
| PS186 | 1969-70 Rear Lower Control Arm w/Rubber Bushings, Boxed, Pair - FS (RE)..... | 199.00/pr. |
| PS186C | 1969-72 Rear Lower Control Arm w/ Urethane Bushings, Boxed, Pair - GP (RE)..... | 219.00/pr. |
| PS186C | 1969-70 Rear Lower Control Arm w/ Urethane Bushings, Boxed, Pair - FS (RE)..... | 219.00/pr. |



PS186CB

- | | | |
|----------------|---|-----------|
| PS186CB | 1969-72 Rear Lower Control Arm Inserts, Pair -GP (AP)..... | 30.00/pr. |
| PS186CB | 1969-70 Rear Lower Control Arm Inserts, Pair - FS (AP)..... | 30.00/pr. |

These inserts convert non-boxed lower control arms to boxed and allow the use of a rear sway bar. These will need to be welded in place and holes will need to be drilled for sway bar bolts.



PS186H

- | | | |
|----------------|--|-------------|
| PS186G | 1965-66 Rear Upper Control Arm w/Rubber Bushing (RE) | \$89.00/ea. |
| PS186GB | 1965-66 Rear Upper Control Arm w/ Urethane Bushing (RE) | 99.00/ea. |
| PS186H | 1969-72 Rear Upper Control Arm w/Rubber Bushing - GP (RE) | 82.00/ea. |
| PS186HB | 1969-72 Rear Upper Control Arm w/ Urethane Bushing - GP (RE) | 92.00/ea. |



PS187

- | | | |
|---------------|--|-----------|
| PS186R | 1961-64 Rear Control Arm Rubber Bushing (Upper or Lower) (NOS) | Disc. |
| PS187 | 1965-70 Rear Lower Control Arm Rubber Bushing, FS (AP)..... | 17.00/ea. |
| PS187 | 1969-72 Rear Lower Control Arm Rubber Bushing - GP (AP)..... | 17.00/ea. |
| PS187 | 1965-70 Rear Upper Control Arm Rubber Bushing - FS (AP)..... | 17.00/ea. |
| PS187 | 1969-72 Rear Upper Control Arm Rubber Bushing - GP exc. 12-Bolt Rear Axle (AP) | 17.00/ea. |



PS190



PS190B

- | | | |
|---------------|--|----------|
| PS190 | 1965-72 Rear Control Arm Bolt (RE) | 7.00/ea. |
| PS190B | 1965-72 Rear Control Arm Nut (RE)..... | 2.00/ea. |

URETHANE CONTROL ARM BUSHINGS

- | | | |
|--------------|---|-----------|
| PS267 | 1965-70 Urethane Rear Axle Control Arm Bushings - FS (AP) | 12.00/ea. |
| PS267 | 1969-77 Urethane Rear Axle Control Arm Bushing - GP (AP)..... | 12.00/ea. |
| PS268 | 1965-70 Urethane Rear Axle Control Arm Bushing Set, 8 Pcs. - FS (AP)..... | 92.00/set |
| PS268 | 1969-77 Urethane Rear Axle Control Arm Bushing Set, 8 Pcs. - GP (AP)..... | 92.00/set |

STABILIZER BARS, RUBBER BUSHINGS & BRACKETS

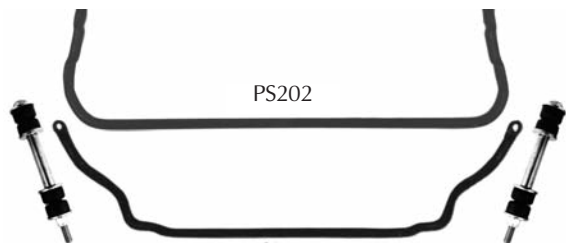

PS202

- | | | |
|---------------|---|------------|
| PS201 | 1973-77 Front Stabilizer Bar (1.25" dia.)- GP (RE) | 99.00/ea. |
| PS202 | 1969-72 Rear Stabilizer Bar (.875" dia.)- GP (GM) | 135.00/ea. |
| PS202F | 1969-72 Heavy Duty Rear Stabilizer Bar (1" dia.) - GP (AP)..... | 129.00/ea. |

PS202F includes bolts and shims.

PS202-PS202F must be used with boxed control arms.

Add \$12.00 oversize fee to standard shipping for stabilizer bars.

For sway bar kits see PS250-PS261K.





PS203

PS203 1969-72 Rear Anti-Sway Bar Shims - GP (RE) \$2.50/ea.

Note: Use as required.

PS203J 1969-72 Rear Anti-Sway Bar Mounting and Shim Kit - GP (RE)..... 15.00/kit

This kit includes: 4 bolts, nuts, washers and 2 shims to mount the rear sway bar to your existing boxed lower control arms.

PS205 1959-64 Front Stabilizer Bar End Link Kit - FS (AP) 28.00/pr.

PS206 1965-70 Front Stabilizer Bar End Link Kit - FS (AP) 19.00/pr.

PS207 1971-76 Front Stabilizer Bar End Link Kit - FS (AP) 17.00/pr.

PS207 1973-77 Front Stabilizer Bar End Link Kit - GP (AP) 17.00/pr.

PS208 1969-72 Front Stabilizer Bar End Link Kit - GP (RE) 18.00/pr.



PS210

PS208T 1955-57 Front Stabilizer Bar to Frame Bushing w/ 3/4" Bar (RE) 32.00/pr.

PS210 Front Stabilizer Bar to Frame Bushing w/ 7/8" Bar (RP) 5.00/ea.

PS211 Front Stabilizer Bar to Frame Bushing w/ 1" Bar (RP) 5.50/ea.

PS212 Front Stabilizer Bar to Frame Bushing w/ 1 1/8" Bar (GM) 6.00/ea.

PS213 Front Stabilizer Bar to Frame Bushing w/ 1 1/4" Bar (GM) 8.00/ea.

To determine correct stabilizer bar diameter measure circumference and divide by 3.14.



PS216

PS216 Front Stabilizer Bar to Frame Bushing Bracket - All exc. 1 1/4" Bar (GM) 10.00/pr.

Note: PS216 will not work with urethane bushings.

PS217 Front Stabilizer Bar to Frame Bushing Bracket w/ 1 1/4" Bar (GM) 23.00/pr.

URETHANE FRONT STABILIZER BUSHINGS



PS230

PS230 Stabilizer Bar to Frame Bushings & Brackets w/3/4" Bar (AP)..... 18.00/set

PS230J Stabilizer Bar to Frame Bushings & Brackets w/ 13/16" Bar (AP)..... 18.00/set

PS231 Stabilizer Bar to Frame Bushings & Brackets w/ 7/8" Bar (AP) 18.00/set

PS231J Stabilizer Bar to Frame Bushings & Brackets w/ 11/16" Bar (AP) 18.00/set

PS232 Stabilizer Bar to Frame Bushings & Brackets w/15/16" Bar (AP)..... \$18.00/set

PS233 Stabilizer Bar to Frame Bushings & Brackets w/1" Bar (AP)..... 18.00/set

PS234 Stabilizer Bar to Frame Bushings & Brackets w/1 1/8" Bar (AP)..... 18.00/set

PS235 Stabilizer Bar to Frame Bushings & Brackets w/1 1/4" Bar (AP)..... 18.00/set

Note: PS230 through PS235 consist of 2 bushings and 2 brackets which mount the stabilizer bar to the frame.

PS245 1965-70 Front Stabilizer End Link Kit - FS (AP).... 18.00/set

PS246 1971-76 Front Stabilizer End Link Kit - FS (AP).... 18.00/set

PS247 1969-72 Front Stabilizer End Link Kit - GP (AP).... 18.00/set

PS246 1973-77 Front Stabilizer End Link Kit - GP (AP).... 18.00/set

FRONT STABILIZER BAR KITS

PS250 1961-64 1 1/8" Front Stabilizer Bar Kit (AP) Disc.

PS250D 1965-70 1 1/8" Front Stabilizer Bar Kit - FS (AP).. 219.00/kit

PS250J 1971-76 1 1/8" Front Stabilizer Bar Kit - FS exc. SW (AP) 179.00/kit

PS250-PS250J are after-product kits which do not mount like originals.



PS252

PS252 1969-72 1 1/4" Front Stabilizer Bar Kit - GP (RE-AP)..... Disc.

PS253 1973-77 1 1/4" Front Stabilizer Bar Kit - GP (RE-AP)..... 129.00/kit

PS252 and PS253 include: 1-reproduction front bar, 2-urethane frame bushings w/brackets, and 2-urethane end links w/bushings.

Comments: These kits have the largest diameter bar that we recommend for street use.

Add \$12.00 oversize fee to standard shipping for sway bar kits.



REAR ANTI-SWAY BAR KITS

PS258D 1961-64 1" Rear Anti-Sway Bar Kit (AP) 269.00/kit

PS258J 1965-76 1" Rear Anti-Sway Bar Kit - FS exc. '71-76 SW (AP)..... Disc.

PS258N 1969-77 1" Rear Anti-Sway Bar - GP (AP)..... 199.00/kit

PS258D-PS258N are after-product kits which may not mount like originals.



PS260

PS260 1969-72 Rear Anti-Sway Bar Kit w/ Rubber Control Arm Bushings - GP (GM-RE) 299.00/kit

PS260K 1969-72 Rear Anti-Sway Bar Kit w/ Urethane Control Arm Bushings - GP (GM-RP) ... 289.00/kit

PS260 and PS260K include two boxed lower control arms (complete w/bushings), the 7/8" anti-sway bar plus necessary hardware to bolt bar to control arms.

Add \$12.00 oversize fee to standard shipping for rear anti-sway bar kits.



Rear anti-sway bars continue on next page.

Rear anti-sway bars continued.



PS261

- PS261** 1969-72 1" Dia. Heavy Duty Rear Sway Bar Kit w/ **Rubber** Control Arm Bushings - GP (AP)..... \$285.00/kit
- PS261K** 1969-72 1" Dia. Heavy Duty Rear Sway Bar Kit w/ **Urethane** Control Arm Bushings -GP (AP) 299.00/kit

These kits are the easiest and most inexpensive way to make your GP handle. They include two boxed lower control arms (complete w/bushings), the 7/8" or 1" dia. treated anti-sway bar plus necessary hardware to bolt bar to control arms.

Add \$12.00 oversize fee to standard shipping for PS261 & PS261K kits.



REAR REINFORCEMENT BRACES



PS262N

- PS262N** 1969-72 Rear Reinforcement Braces - GP (RE).... 65.00/ea.

By 1969 GM realized that the heavy acceleration loads placed on the GP rear ends were causing stress fractures in the rear control arm bracket and frame areas. These GM service part braces were designed to strengthen these weaknesses and are recommended for all applications.

Comments: A very close reproduction of the factory part.

TRACTION BARS



PS276

- PS275** 1961-64 Adjustable Traction Bar Kit (AP)..... Inquire
- PS276** 1969-72 Adjustable Traction Bar Kit - GP (AP) ... Inquire

These traction bar kits are designed to reduce wheel hop and wheel spin, which will greatly improve acceleration. They are adjustable to fine tune to your application.

Note: These bars do not have provisions for mounting a rear sway bar.

SHOCK ABSORBERS & COMPONENTS

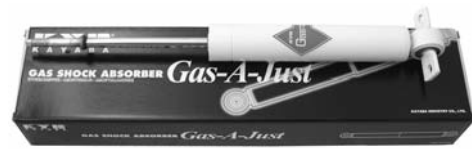

 Gas shocks cannot be shipped by air or outside the Continental United States.

For superior road handling at a reasonable price KYB Gas-a-just shocks are simply the best. 280 p.s.i. of N2 gas give these shocks extremely quick rebound action keeping tires firmly on the road without any shock fade generally associated with hydraulic shocks.

Comments: Finest quality shocks for the price. Limited Lifetime Warranty.

- PS280** 1958-62 Front Gas Shocks, Exc. AS (AP) \$99.00/pr.

Note: For PS280 applications, mounting holes may need to be elongated on bottom of shock.

- PS281** 1963-70 Front Gas Shocks - FS (AP) 99.00/pr.
- PS282** 1971-76 Front Gas Shocks - FS (AP) 99.00/pr.
- PS283** 1969-77 Front Gas Shocks - GP (AP) 99.00/pr.
- PS284** 1958-62 Rear Gas Shocks, Exc. AS (AP) 99.00/pr.

Note: PS284 will not work on cars equipped with shocks that have studs on both ends. We cannot supply a shock for this application.

- PS285** 1963-70 Rear Gas Shocks, Exc. SW or HD Susp. - FS (AP)..... 99.00/pr.
- PS286** 1969-70 Rear Gas Shocks w/HD Susp. or SW - FS (AP)..... 99.00/pr.
- PS287** 1971-76 Rear Gas Shocks Exc. SW or HD Susp. - FS (AP)..... 99.00/pr.
- PS289** 1969-77 Rear Gas Shocks - GP (AP) 99.00/pr.

Shock absorber components continue on next page.

DON'T BACKORDERS MAKE YOU HOPPING MAD?



Needless backorders are aggravating, costly, and time-consuming. Each year we've become more efficient reaching an unbelievably low backorder rate. Last year 94.9% of all invoices were shipped without backorders and 98.7% of all items ordered were shipped without backorders.

If you want your parts NOW (and we mean ALL your parts) or have questions, call:

(800) 421-2637 (AMES).

SUSPENSION/STEERING

Shock absorber components continued.



PS289T

PS289T Shock Paint (Gray) 11 oz. Aerosol (AP). \$6.50/ea.
This is the correct gray paint used on original Delco shocks.



Paint cannot be shipped by air or outside the continental United States.



PS290

PS290 1955-77 Urethane Front Shock Absorber Upper Grommets, 4 Pcs. (AP) 5.00/set
This kit contains enough to do two shocks.

PS291 1958-77 Urethane Rear Shock Absorber Lower Grommets, w/Original-style Shocks, 2 Pcs. (AP) 4.00/pr.
This kit contains enough to do two shocks.

PS292 1958-77 Urethane Rear Shock Absorber Lower Grommets, w/KYB Gas Shocks, 2 Pcs. (AP) 4.00/pr.
This kit contains enough to do two shocks.



PS295J

PS295 1964-77 Front Lower Control Arm Shock Nuts (RP) Disc.
These are the nuts that push on the lower control arm.

PS295J 1964-77 Front Shock Mounting Kit (RP) 14.00/set
This kit contains four shock nuts and four bolts to replace your originals.

FRONT COIL SPRINGS

YEAR	MODEL & BODY STYLE	w/o AC		w/AC	
		REG	HD	REG	HD
1955-57	ALL	PS298		PS299	
1958	ALL exc. SW	PS300		PS304	
1959-60	ALL	PS304		PS308	
1961	ALL	PS300		PS308	
1962-63	ALL	PS304		PS308	
1964	ALL	PS304		PS308	
1965	Catalina Conv.	PS320		PS312	PS308
1965	Catalina HT	PS320		PS312	PS324
1965	Star Chief, Bonneville, Grand Prix	PS300	PS308	PS312	PS324
1966	Catalina 2 Dr.	PS320	PS308	PS312	PS308
1966	Catalina 2 Dr. HT	PS320	PS308	PS312	PS324
1966	Catalina Conv.	PS300	PS308	PS312	PS308
1966	2+2 ALL	PS304	PS308	PS324	PS324
1966	Star Chief, Bonneville 2 Dr. HT	PS328	PS308	PS312	PS324
1966	Bonneville Conv.	PS300	PS308	PS304	PS324
1966	Grand Prix	PS300	PS308	PS312	PS308
1967	Catalina 2 Dr.	PS300	PS308	PS312	PS324
1967	Catalina 2 Dr. HT	PS320	PS308	PS312	PS324
1967	Catalina Conv.	PS320	PS308	PS312	PS324
1967	Executive & Bonneville 2 Dr. HT	PS300	PS308	PS312	PS324
1967	Bonneville Conv.	PS300	PS308	PS304	PS324
1967	Grand Prix	PS320	PS324	PS312	PS324
1968	Catalina 2 Dr.	PS328	PS308	PS304	PS324
1968	ALL exc. Catalina 2 Dr.	PS328	PS308	PS332	PS324
1969	ALL exc. Bonneville & GP	PS312	PS308	PS332	PS324
1968	Bonneville HT & Conv.	PS312	PS308		PS324
1969-71	Grand Prix		PS310		PS336
1970	ALL exc. Grand Prix	PS312	PS308	PS332	PS324
1971	ALL exc. Grand Prix	PS316	PS308		PS344
1972	Catalina Conv.		PS348		PS348
1972	Grand Prix		PS348	PS336	
1973	ALL exc. GP	PS316	PS340	PS344	PS340
1974	ALL exc. GP	PS344	PS340	PS346	PS334
1975-76	ALL exc. GP	PS348	PS340	PS348	PS334
1973-77	Grand Prix	PS342	PS308	PS338	PS324

PS298 Front Springs w/o AC (AP)..... \$185.00/pr.
PS299 Front Springs w/ AC (AP)..... 185.00/pr.

Note: You must give year, make, model, transmission type, and engine size when ordering PS298 & PS299.

PS300	Front Springs (AP).....	136.00/pr.
PS304	Front Springs (AP).....	106.00/pr.
PS308	Front Springs (AP).....	122.00/pr.
PS310	Front Springs (AP).....	115.00/pr.
PS312	Front Springs (AP).....	116.00/pr.
PS316	Front Springs (AP).....	109.00/pr.
PS320	Front Springs (AP).....	122.00/pr.
PS324	Front Springs (AP).....	142.00/pr.
PS328	Front Springs (AP).....	122.00/pr.
PS332	Front Springs (AP).....	119.00/pr.
PS334	Front Springs (AP).....	Disc.
PS336	Front Springs (AP).....	119.00/pr.
PS338	Front Springs (AP).....	119.00/pr.
PS340	Front Springs (AP).....	99.00/pr.
PS342	Front Springs (AP).....	95.00/pr.
PS344	Front Springs (AP).....	124.00/pr.
PS346	Front Springs (AP).....	124.00/pr.
PS348	Front Springs (AP).....	159.00/pr.

Add 15.00 oversize fee to standard shipping for PS298 & PS299 and \$10.00 oversize fee for PS300-PS348.



SAVE TIME
ORDER ONLINE

24
Hours
A
Day

www.amesperf.com

REAR COIL SPRINGS



YEAR	MODEL & BODY STYLE	w/o AC		w/AC	
		REG	HD	REG	HD
1958-60	ALL	PS349	PS349		
1961-64	ALL	PS370	PS350	PS370	PS350
1965-66	ALL	PS353		PS353	
1967-69	Catalina 2 Dr. HT	PS355		PS355	
1967-68	Catalina Conv.	PS355	PS360	PS355	PS360
1967-68	Bonneville, Executive-ALL Models	PS365	PS360	PS365	PS360
1967	Grand Prix	PS370	PS360	PS370	PS360
1968	Grand Prix	PS355	PS375	PS355	PS375
1969	Catalina Conv.	PS370		PS370	
1969	Bonneville and Executive, 2 Dr. HT	PS365		PS365	
1969	Bonneville and Executive, Conv.	PS380		PS380	
1969-72	Grand Prix.	PS385		PS385	
1970	Catalina ALL 2 Dr.	PS370		PS370	
1970	Bonneville and Executive, ALL 2 Dr.	PS365		PS365	
1971	Catalina, ALL	PS390		PS390	
1971-72	Bonneville & Grandville, Conv.	PS395		PS395	
1971-72	Bonneville & Grandville, 2 Dr. HT	PS390		PS390	
1972	Catalina 2 Dr. HT	PS395		PS390	
1972	Catalina Conv.	PS395		PS395	
1973	ALL exc. Grand Prix	PS395		PS395	
1974-76	ALL exc. Grand Prix	PS397	PS393	PS397	PS393
1973-77	Grand Prix	PS370	PS380	PS370	PS380

PS349 1958-60 Rear Springs (AP)..... \$195.00/pr.

Note: You must give year, make, model, transmission type, and engine size when ordering PS349.

- PS350** Rear Springs (AP)..... 99.00/pr.
- PS353** Rear Springs (AP)..... 159.00/pr.
- PS355** Rear Springs (AP)..... 109.00/pr.
- PS360** Rear Springs (AP)..... 103.00/pr.
- PS365** Rear Springs (AP)..... 122.00/pr.
- PS370** Rear Springs (AP)..... 103.00/pr.
- PS375** Rear Springs (AP)..... 119.00/pr.
- PS380** Rear Springs (AP)..... Disc.
- PS385** Rear Springs (AP)..... 99.00/pr.
- PS390** Rear Springs (AP)..... 69.00/pr.
- PS393** Rear Springs (AP)..... 99.00/pr.
- PS395** Rear Springs (AP)..... 99.00/pr.
- PS397** Rear Springs (AP)..... 119.00/pr.

Add 12.00 oversize fee to standard shipping for PS349 and \$10.00 oversize fee for PS350 - PS397.



SPRING INSULATORS



PS399

- PS398T** 1958 Rear Spring Insulators (RE) 33.00/pr.
 - PS399** 1961-64 & 1967-77 Rear Spring Insulators (GM) 7.50/pr.
 - PS399B** 1965-66 Rear Spring Insulators (RE) 20.00/pr.
- PS398T-PS399B are the insulators that mount between the top of the spring and the frame.
- PS399R** 1961-64 Rear Spring Lower Holddown Kit (RE).. 16.00.kit

1955-60 BODY MOUNTS & HARDWARE



PS401

PS401 1955-57 Body Mount Assembly - HT (RE)..... \$9.00/asm.

Note 1: Each assembly consists of one rubber and steel upper body mount and one rubber lower body mount. Square mount measures 2 1/16" x 2 1/16" x 1/2" thick.

Note 2: These hardtop mounts are supplied with a thin sheet metal spacer designated by original GM part numbers. (Several of our customers' cars do not have this spacer. If your car was assembled without shims, simply remove from our mounts and discard.)

PS402K 1958 Body Mount Assembly - HT (RE)..... 9.00/asm.

Each assembly consists of one rubber and steel upper body mount and one rubber lower body mount. Square mount measures 2 1/16" x 2 1/16" x 1/2" thick.

PS403K 1959 Body Mount Assembly - HT (RE)..... 9.00/asm.

PS404 1960 Body Mount Assembly - HT (RE)..... Inquire



PS405K

PS405K 1955-60 Body Mount Assembly - CVT (RE)..... 6.00/asm.

Each assembly consists of one flat rubber square and one flat rubber round body mount. Square mount measures 1 3/4" x 2 1/4" x 5/16" thick.

Note: We have found some 55-60 convertibles use a square mount with a steel sleeve - measuring about 1/2" in thickness. Please use PS401 if you have this style mount.

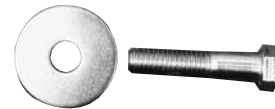

PS407

PS407 1955-60 Body Mount Hardware Assembly - HT and CVT (AP) 1.75/asm.

Each assembly consists of one grade five bolt and one special body mount washer.

Purchase a Gift Certificate for an enthusiast!
(800)421-2637



SUSPENSION/STEERING

1961-72 FULL-SIZE BODY MOUNTS & HARDWARE

1961-72 full-size Pontiacs (except 1969-72 GP's) used several different body mounts in various combinations. With so many variations, we are offering our mounts as individual assemblies in order for each customer to select the correct combination of mounts for his car. Use the following dimensions to identify the mounts for your application.

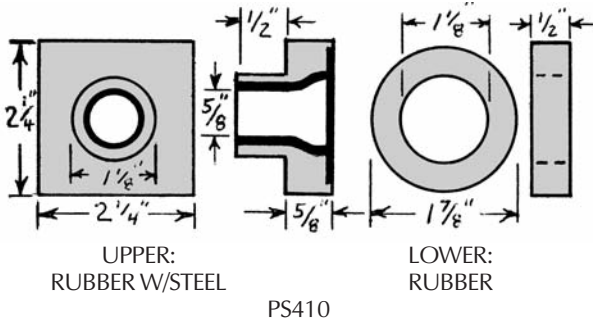

PS410 Body Mount Assembly, Upper & Lower - FS (RE) \$10.00/asm.

Use PS420 body mount hardware with this assembly.

Note: A few original mount assemblies we received had a small thin lower mount (1 5/8" OD). In all cases we will be supplying the large stronger, more common mount illustrated above.

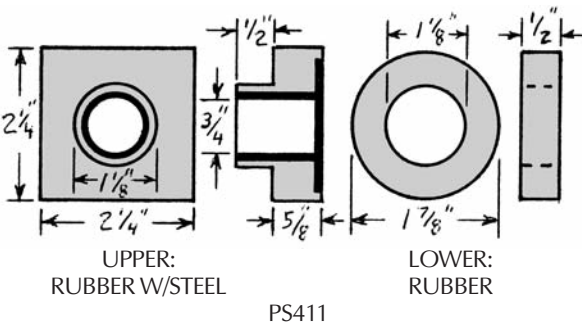

PS411 Body Mount Assembly, Upper & Lower - FS (RE) 9.00/asm.

Use PS420 body mount hardware with this assembly. The upper mount in this assembly is similar to PS410. However, it is distinguished by the much larger inside hole diameter and straight tube hole design.

Note: A few original mount assemblies we received had a small thin lower mount (1 5/8" OD). In all cases we will be supplying the large stronger, more common mount illustrated above.

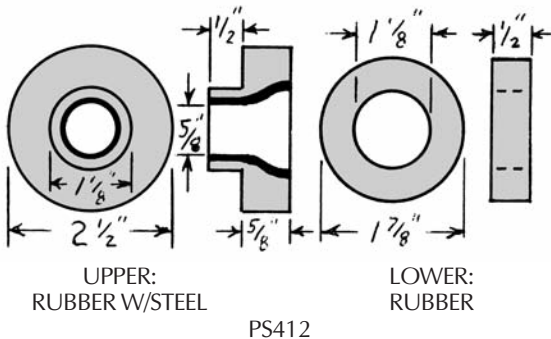

PS412 Body Mount Assembly, Upper & Lower - FS (RE) 10.00/asm.

Use PS420 body mount hardware with this assembly.

Note: A few original mount assemblies we received had a small thin lower mount (1 5/8" OD). In all cases we will supply the large stronger, more common mount illustrated above.

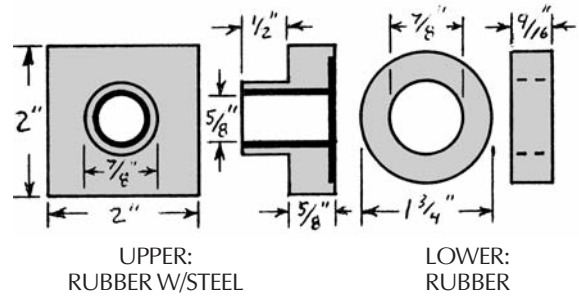

PS413 Body Mount Assembly, Upper & Lower - FS (RE) \$10.00/asm.

Use PS421 body mount hardware with this assembly.

Note: This mount seems to have two applications. In some cases it functions as a true body mount using a lower mount and bolt. In other applications it has no bolt and is simply a rider or dummy (see PS414).

PS414 Body Mount - Upper Only - FS (RE)..... 7.00/ea.
Note: Refer to upper mount diagram for PS413.

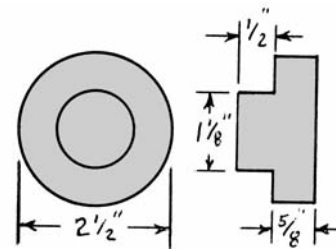

PS415 Upper Body Mount - FS (RE) 5.00/ea.

This mount is rubber only with no hole for a bolt. It is used simply as a rider or dummy.

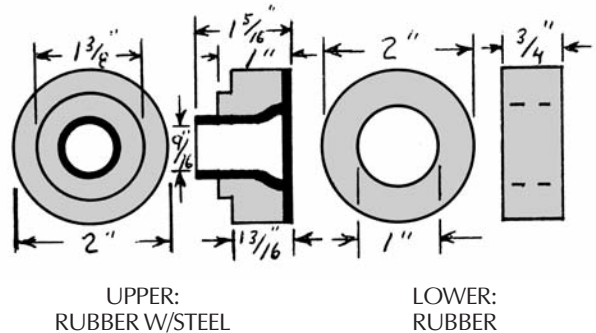

PS416 Body Mount Assembly, Upper & Lower - FS (RE) 9.00/asm.

Use PS422 body mount hardware with this assembly.

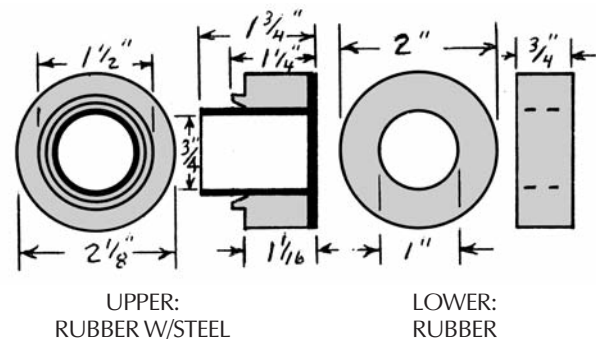

PS417 Body Mount Assembly, Upper & Lower - FS (RE) 9.00/asm.

Use PS422 body mount hardware with this assembly.

SUSPENSION/STEERING



PS420

- PS420** Body Mount Hardware Assembly
- FS (AP)..... \$1.75/asm.

This assembly consists of one 7/16" x 2" bolt and one special 1 7/8" body mount washer.

- PS421** Body Mount Hardware Assembly
- FS (AP)..... 1.75/asm.

This assembly consists of one 7/16" x 2" bolt and one special 1 5/8" body mount washer.

- PS422** Body Mount Hardware Assembly
- FS (AP)..... 1.75/asm.

This assembly consists of one 7/16" x 3" bolt and one special body mount washer.

1969-77 GP BODY MOUNT & HARDWARE KITS

- PS425** 1969-72 Body Mount Set - GP (RE) 89.00/set

This set includes all upper and lower body mounts necessary for one car. See PS441 for core support mounting kit.

- PS426** 1969-72 Body Mount Hardware Kit - GP (AP) 18.00/kit

This kit includes the correct 2" x .525" x .125" washers plus enough grade 5 bolts to install a full set of body mounts.

- PS430** 1973-77 Body Mount Set - GP (GM) Disc.

This set includes all upper and lower body mounts necessary for one car.

- PS431** 1973-77 Body Mount Bolt Kit - GP (AP) 8.00/kit

This kit contains enough bolts to install PS430.

CORE SUPPORT MOUNTING KITS

Note: The following core support kits contain all necessary mounts, bolts, and washers for your restoration.

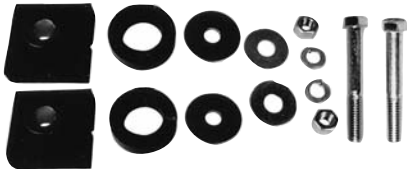

PS435

- PS435** 1961-64 Core Support Mounting Kit - FS (RE) 20.00/kit

- PS435K** 1961-64 Core Support Shims - FS (RE)..... 2.00/ea.

These are the special square shims used to adjust the core support with respect to the frame.

- PS437** 1965 Core Support Mounting Kit - FS (RE) 22.00/kit

This is a one-year only kit. Although the upper mounts look similar to several round body mounts now available, dimensions between the two are not compatible.

- PS437K** 1965 Core Support Shims - FS (RE)..... 1.00/ea.

These are the round shims used to adjust the core support with respect to the frame.

- PS439** 1966-72 Core Support Kit - FS (RE)..... 12.00/kit

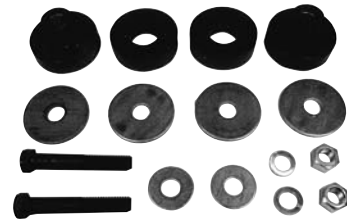

PS441

- PS441** 1969-72 Core Support Kit - GP (RE) \$12.00/kit

- PS441J** 1969-72 Core Support Mount Flange Nuts - GP (RE) 23.00/pr.

- PS443** 1973-74 Core Support Kit - GP (RE) Inquire

- PS445** 1975-77 Core Support Kit - GP (RE) Inquire

FRAME REPAIR KIT



PS448

- PS448** 1969-72 Frame Repair Kit - GP (RP) 29.00/kit

This kit is used to repair rusted-out frame rail body mount holes. This is a common rust area as moisture is trapped between the rubber mount and the frame. Kit contains 14 washers unique in size and gauge.

PAINT & UNDERCOATING



Paint cannot be shipped by air or outside the continental united states.



PS470

- PS470** Chassis Black 15 oz. Aerosol (AP) 14.00/ea.

This coating is used on the front A-arms, frame and other suspension components. We have found this epoxy-hardened, chip-resistant paint to be the best on the market.



PS472

- PS472** 3M Rubberized Undercoating, 20 Oz. Aerosol Can (AP)..... 15.00/ea.

The best aerosol undercoating we've found. Excellent for factory undercoated seams (such as inner and outer rear wheelwell seams, transmission hump seams, etc.).



PS474

- PS474** POR 15 Chassis Coat (AP) 45.00/qt.

Use as a UV-resistant top coat or as an original-style frame and suspension finish. It resists scratches and abrasions extremely well which makes it an excellent finish for frame and suspension components.

- PV842** Power Steering Fluid, 16 oz 7.00/ea.

Light-bodied mineral oil that contains a specially developed additive package to provide good performance in power steering systems.

SUSPENSION / STEERING

WHEELS

8 LUG WHEEL COMPONENTS



PT295



PT297

PT295 1960-63 8-Lug Aluminum Color Drum Paint, 12 oz. Aerosol Can (AP) \$12.00/ea.

There is controversy on whether these early drums were painted or left natural. Many people feel their original drums were painted, so we've decided to supply this bare aluminum color paint.

PT297 1964-68 8-Lug Black Wheel Paint (Semi-Gloss), 12 oz. Aerosol Can (AP) 12.00/ea.

 Paint cannot be shipped by air or outside the continental united states.



PT147

PT147 1960-62 Trim Rings for 8-Lug Wheel (RE) \$26.00/ea.

PT148 1960-62 Trim Rings for 8-Lug Wheel, Set of 4 (RE) 99.00/set



PT149

PT149 1963-68 Trim Rings for 8-Lug Wheel (APE) 79.00/ea.

PT150 1963-68 Trim Rings for 8-Lug Wheels, Set of 4 (APE) 299.00/set

Quality: Shape, fit, and finish are excellent.



PT170



PT170C

PT170 1960-68 8-Lug Hold-Down Plate (APE) 35.00/ea.

Note: This plate is stamped like originals. It is made from the same thickness stock, has the correct crimped notches, and is stamped to have the correct concave contour. The plate was used not only to anchor the eight-lug spare in the trunk, but also to hold the rim securely when mounting and dismounting the tire. Not intended for spin-balancing purposes.

Comments: Best quality available.

PT170C 1960-68 8-Lug Wheel Balancer Adaptor (RE) 75.00/ea.

This precision cut and balanced adaptor plate allows Pontiac 8-Lug wheels to be speed balanced on a conventional tire balancer. Comes painted black with studs installed.



PT152R



PT153R



PT100A

PT152 1960-62 Wheel Lug Nut Set (8-Lug Wheel), 16 LH Thread, 16 RH Thread - 1/2" - Stainless Steel (APE) 169.00/set

PT152L 1960-62 Wheel Lug Nut (8-Lug Wheel), LH - 1/2" - Stainless Steel (APE) 6.00/ea.

PT152R 1960-62 Wheel Lug Nut (8-Lug Wheel), RH - 1/2" - Stainless Steel (APE) 6.00/ea.

PT153 1963 Wheel Lug Nut Set (8-Lug Wheel), 16 LH Thread, 16 RH Thread - 1/2" - Stainless Steel (APE) 169.00/set

PT153L 1963 Wheel Lug Nut (8-Lug Wheel), LH - 1/2" - Stainless Steel (APE) 6.00/ea.

PT153R 1963-68 Wheel Lug Nut (8-Lug Wheel), RH - 1/2" - Stainless Steel (APE) 6.00/ea.

PT154 1964-68 Wheel Lug Nut (8-Lug Wheel), 32 RH Thread - 1/2" - Stainless Steel (APE) 169.00/set

PT152 - PT154 are all highly polished stainless steel.

PT168J 1960-70 Front Wheel Stud - Drum exc. 8-Lug - FS - RH thread 1/2" (RP) 2.00/ea.

PT168L 1965-68 Front Wheel Stud - 8-Lug Drum - FS - RH thread 1/2" (RP) Disc.

PT100A 1955-77 "Correct Style" Valve Stem Cap w/ Nipple (RE) 1.00/ea.



PT140



PT144

PT140 1960-62 8-Lug Wheel Center Cap (APE) 49.00/ea.

PT140A 1960-62 8-Lug Wheel Center Cap Set (APE) 189.00/set

Comments: Excellent.

PT144 1965-68 8-Lug Wheel Center Cap (APE) 55.00/ea.

PT144A 1965-68 8-Lug Wheel Center Cap Set (Set of 4) (APE) 209.00/set

Made to the same quality specs as our highly successful 1960-62 caps.

Quality: Excellent

WHEELS

RALLY II WHEELS & COMPONENTS



New Rally II wheels are being reproduced. Stamped like original, these powder-coated wheels have been safety-tested and approved. As with all factory wheels, these reproductions will have some degree of irregularities in their stampings. Wheels come silver powder-coated with a pre-painted charcoal center, however, charcoal and silver varies from original.

There is no warranty on the finish of these wheels. Therefore, prior to mounting, they should either be re-painted or clear-coated.

Quality: Very good.

PT401	1969-72 14 x 6" Rally II Wheel GP Only (RE).....	Inquire
PT402	1969-72 14 x 7" Rally II Wheel GP Only (RE).....	Inquire
PT403	1969-72 15 x 7" Rally II Wheel GP Only (RE).....	\$179.00/ea.
PT404	1969-72 15 x 8" Rally II Wheel GP Only (RE).....	185.00/ea.
PT405	1969-72 15 x 10" Rally II Wheel GP Only (RE)...	199.00/ea.

Interference issues may result by using non-stock **15X8 & 15X10** wheels. Please inquire for more information

Add \$12.00 oversize fee to standard shipping for wheels.



PT101K



PT103K

These cap components will greatly enhance the appearance of your Rally II Wheels. All components are available separately or as assemblies.

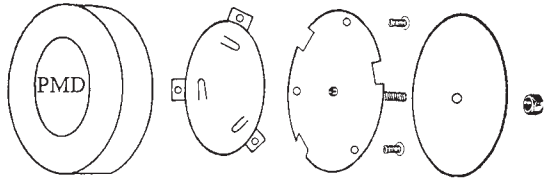

PT101K

PT101K	1967-Early 1970 Black PMD Rally II Complete Caps (APE)	29.00/ea.
PT101L	1967-Early 1970 Black PMD Rally II Complete Caps (Set of 4) (APE).....	116.00/set
PT102	Late 1970-72 Red PMD Rally II Complete Caps (GM)	Disc.
PT102B	Late 1970-72 Red PMD Rally II Complete Cap Set (GM).....	Disc.

PT102 & PT102B are GM caps with the original style clips.

For those requiring original equipment caps, we will continue to offer these products until discontinued by GM.

PT102K	Late 1970-72 Red PMD Rally II Complete Caps (APE)	29.00/ea.
PT102L	Late 1970-72 Red PMD Rally II Complete Caps (Set of 4) (APE).....	116.00/set
PT103K	1967-Early 1970 Black PMD Rally II Lucite Centers (APE)	15.00/ea.
PT104K	Late 1970-72 Red PMD Rally II Lucite Centers (APE)..	15.00/ea.



PT106

PT106	1973-75 Rally II Centers (GM)	Disc.
PT106A	1976-77 Rally II Centers (GM)	Disc.
PT106D	1967-72 Rally II Center Cap Locks (APE).....	\$22.00/set

These locks use the same style locking arrangement as our reproduction Rally II center caps. See diagram above PT101K.

PT106F	1973-75 Rally II Center Cap Loc (AP).....	Disc.
---------------	---	-------

Note: These work only on the early wheels that have three notches on the center hole circumference.



PT156A

PT155	1967-70 Rally II Lug Nut Set, 20 pcs. (Black Center 1/2" Thread) -FS (RE).....	75.00/set
PT155A	1967-70 Rally II Lug Nuts (Black Center 1/2" Thread) - FS (RE).....	4.00/ea.

These chrome-plated steel nuts are excellent down to the black plastic insert.

For red insert see PT155C & PT155D

PT155C	1967-70 Rally II Lug Nut Set 20 pcs. (Red Center 1/2" Thread) -FS (RE)	75.00/set
PT155D	1967-70 Rally II Lug Nuts (Red Center 1/2" Thread) - FS (RE).....	4.00/ea.
PT156	1969-70 Rally II Lug Nut Set 20 pcs. (Black Center 7/16" Thread) - GP (APE).....	49.00/set
PT156A	1969-70 Rally II Lug Nuts (Black Center 7/16" Thread) - GP (APE).....	2.50/ea.
PT157	1969-70 Rally II Lug Nut Set 20 pcs. (Red Center 7/16" Thread) - GP (APE).....	49.00/set
PT157A	1969-70 Rally II Lug Nuts (Red Center 7/16" Thread) - GP (APE).....	2.50/ea.

An exact reproduction using GM's blueprint with correct steel, correct dimensions, and correct threads. We also had these nuts thread-tested by the watch dogs of the after-product market, SEMA and FSI.

Comments: Finest on the market.



PT158

PT158	1971-77 Grand Prix Lug Nuts w/Rally II Wheels 7/16" Thread (GM)	2.00/ea.
PT158A	1971-77 Grand Prix Lug Nut Set w/Rally II Wheels 7/16" Thread, 20 pcs.(GM).....	35.00/set
PT159	1971-77 Full-Size Lug Nuts w/Rally II Wheels - 1/2" Thread (GM)	2.00/ea.
PT159A	1971-77 Full-Size Lug Nut Set w/Rally II Wheels - 1/2" Thread, 20 pcs. (GM).....	35.00/set

PT158-PT159A stainless steel capped nuts can also be used on earlier cars with Rally II wheels.

Rally II wheel components continue on next page.

WHEELS

Rally II wheel components continued.



PT111H

- PT111F** 1967-71 Replacement Trim Rings for 14 x 6-inch Rally II Wheels (GM) \$49.00/ea.
- PT111H** 1967-71 Set of Four PT111F's (GM)..... 196.00/set

This excellent GM replacement is the same as original except that it is polished on all surfaces and has a different clip arrangement.

- PT111K** 1967-77 Trim Ring Set for 14 x 6-inch Rally I & Rally II Wheels, Stainless (AP) Disc.

This is an aftermarket ring and has no resemblance to originals.

- PT112F** 1969-72 Trim Rings for 14 x 7-inch Rally II Wheels (RE) 25.00/ea.
- PT112H** 1969-72 Set of Four PT112F's (RE) 99.00/set

These new reproductions are exact and affordable.

- PT113F** 1969-72 Trim Rings for 14 x 7-inch Rally II Wheels (GM) 49.00/ea.
- PT113H** 1969-72 Set of Four PT113F's (GM) 195.00/set
- PT113K** 1969-72 14 x 7-inch Rally II Trim Rings (GM) 196.00/set

These have the same contours as original, but are 2 1/2" deep instead of 3"-an excellent low-cost alternative.

Note: Original design 1973-'77 14 x 7-inch trim rings are discontinued. PT112H, PT113H, and PT113K can be used as replacements.

- PT113L** 1969-75 Trim Rings for 15 x 6-inch Rally II Wheels (RE) Disc.
- PT113M** 1969-75 Set of Four PT113L's (RE)..... Disc.

These have the correct 2" depth used on 15 x 6" wheels.

- PT113N** 1970-77 Trim Rings for 15 x 7-inch Rally II Wheels (RE) 29.00/ea.
- PT113P** 1970-77 Set of Four PT113N's (RE) 109.00/ea.

These have the same shape as GM's early design. Quality is superb and highly recommended.

- PT114F** 1970-73 Trim Rings for 15 x 7-inch Rally II Wheels (GM) 252.00/ea.
- PT114H** 1970-73 Set of Four PT114F's (GM) 999.00/set
- PT114K** 1973-77 Trim Rings for 15 x 7-inch Rally II Wheels (GM) Disc.

NO ADDITIONAL DISCOUNTS AVAILABLE ON TRIM RING SETS PT111F THROUGH PT114K.



PT301

- PT301** Rally I and Rally II Silver Wheel Paint, 12 oz. Aerosol Can (AP) 8.00/ea.
- PT305** Rally II Charcoal Wheel Paint, 12 oz. Aerosol Can (AP)..... 13.00/ea.

For years, controversy has circulated concerning the Rally II charcoal paints available from various vendors.

In an effort to resolve these questions, we have compared an NOS '71 spare wheel and tire with several spares from low mileage originals.

Comments: Absolutely the best we've seen.

Paint cannot be shipped by air or outside the continental united states.

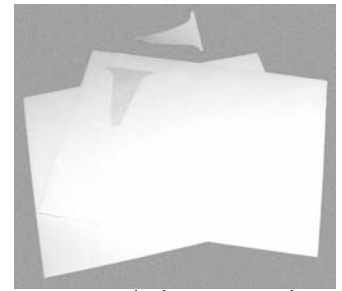

Paint cannot be shipped by air or outside the continental united states.

- PT309** 1967-77 14" Rally II Mask Kit (5 Wheels) (RE)..... \$8.00/kit
- PT311** 1969-77 15" Rally II Mask Kit (5 Wheels) (RE)..... 8.00/kit

The fastest, most sensible way to paint Rally II wheels. Simply sand-blast, prime and paint wheels silver. Apply mask kit, tape off perimeter, and paint the center charcoal.

- PT317** 14" Rally II Paint Kit (AP)..... 35.00/kit
- PT318** 15" Rally II Paint Kit (AP)..... 35.00/kit

PT317 and PT318 contain enough silver and charcoal paint and a masking kit to repaint 5 Rally II wheels.

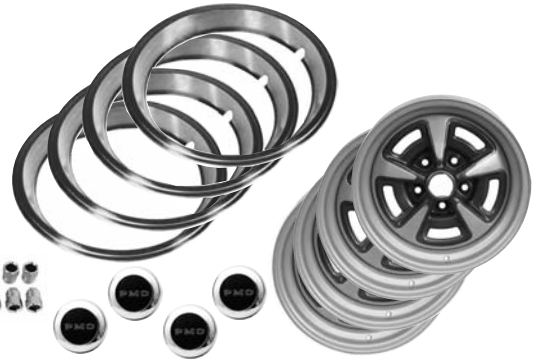

- PT410** 14 x 6" Rally II Wheel Set - GP (RE) Inquire
- PT411** 14 x 7" Rally II Wheel Set - GP (RE) Inquire
- PT412** 15 x 7" Rally II Wheel Set - GP (RE) 939.00/set

Included in this wheel set are four wheels, trim rings, plus your choice of red (PT157) or black (PT156) Rally II lug nuts, and either black (PT101L) or red (PT102L) Rally II center caps. Please specify when ordering.

- PT413** 15 x 8" Rally II Wheel Set - GP (RE)..... 959.00/set
- PT415** 15 x 10" Rally II Wheel Set - GP (RE)..... 1013.00/set

Included in these wheel sets are four 15X8" (PT404) or 15X10" (PT405) wheels, original GM trim rings (PT113P), plus your choice of red (PT157) or black (PT156) Rally II lug nuts, and either black (PT101L) or red (PT102L) Rally II center caps. Please specify when ordering.

No further discounts apply to wheel sets.

Add \$48.00 oversize fee to standard shipping for complete wheel sets.



- PT100A** 1955-77 "Correct Style" Valve Stem Cap w/ Nipple (RE)..... 1.00/ea.

WHEELS

STEEL WHEELS, HUBCAPS & COMPONENTS



PT131

PT131 1969-72 GP 14X6 OEM Style Steel Wheel
Except Disc Brakes..... \$90.00/ea.

PT132 1959-74 15X6 OEM Steel Wheel,
All Except GP..... 97.00/ea.

Add \$12.00 oversize fee to standard shipping for wheels.



PT109

PT109 1963-64 Wire Wheel Hubcap Decal (RE) \$26.00/set

Comments: Excellent—these are anodized red.

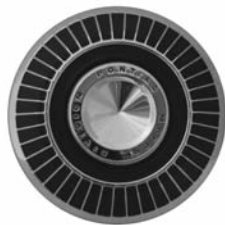

PT125

PT125 1964-71 Pontiac Motor Division
Poverty Hub Cap (APE)..... 72.00/ea.

PT125A 1964-71 Pontiac Motor Division
Poverty Hub Cap Set (APE) 288.00/set

These are the first design standard 10 1/2" diameter 42 rib hubcap used by GM as their base cap.

Quality: Excellent.



PT106BH

PT106BH 1967-70 Wheelcover Lucite Center (Black)
- PMD (2 7/16" dia.) (RE)..... 23.00/ea.

PT106BL 1967-70 Wheelcover Lucite Center (Black)
- PMD (2 3/4" dia.) (RE) 23.00/ea.

PT106BN 1967-70 Wheelcover Lucite Center (Black)
- Power Disc Brake (2 7/16" dia.) (RE) ... 23.00/ea.

PT106BR 1970-72 Wheelcover Lucite Center (Red)
- PMD (2 7/16" dia.) (RE)..... 23.00/ea.

PT106BT 1970-72 Wheelcover Lucite Center (Red)
- PMD (2 3/4" dia.) (RE) 23.00/ea.

PT106BV 1970-72 Wheelcover Lucite Center (Red)
- Power Disc Brake (2 7/16" dia.) (RE) ... 23.00/ea.

Note: These are Lucites only.



PT106BT



PT108RC

PT108RC 1951,53 Wire Wheel Lucite Center
(Silver/Red) (RE)..... 85.00/ea.

PT108RE 1952 Wire Wheel Lucite Center
(Gold/Red) (RE) 85.00/ea.

These lucites are also used for the grille emblem.



PT164S

PT164L 1960-63 Steel Wheel Standard Lug Nut -
LH Thread 1/2" (RP)..... 2.00/ea.

PT164R 1960-77 Steel Wheel Standard Lug Nut - FS
RH Thread 1/2" (RP) 2.00/ea.

PT164S 1969-77 Steel Wheel Standard Lug Nut - GP
RH Thread 7/16" (RP) 1.00/ea.

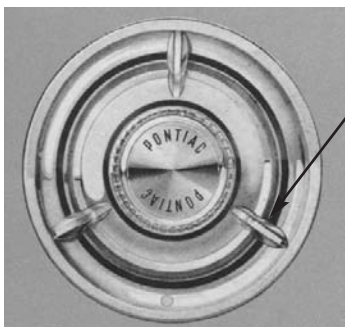

PT120

PT120 1958 Custom Wheel Cover Outer Spokes (RE) 11.00/ea.
Note: 3 required per wheel.



PT100A

PT100A 1955-77 "Correct Style" Valve Stem Cap
w/ Nipple (RE)..... 1.00/ea.

W H E E L S

HONEYCOMB WHEEL COMPONENTS



PT108

PT107	1971	Honeycomb Wheel Ornament - GP (RE).....	\$59.00/ea.
PT108	1972-77	Honeycomb Wheel Ornament - GP (GM).....	169.00/ea.



PT106j

PT106j	1971-76	Honeycomb Cap Loc (AP).....	Inquire
---------------	---------	-----------------------------	---------

PT106F and PT106j are used to keep your caps from falling off or being stolen. The Cap Loc™ fills a long-felt need. They work well; however, if they appear loose, bend the spring retainer on the cap for more tension.



PT158

PT158	1971-77	Grand Prix Lug Nuts w/ Honeycomb Wheels, 7/16" Thread (GM)	\$2.00/ea.
PT158A	1971-77	Grand Prix Lug Nut Set w/ Honeycomb Wheels, 7/16" Thread, 20 pcs.(GM).....	35.00/set



PT115F

PT114P	1973-77	Set of Four PT114K's (RE)	Disc.
PT115F	1971-75	Trim Rings for 14 x 7-inch Honeycomb Wheels (RE)	65.00/ea.
PT115H	1971-75	Set of Four PT115F's (RE)	255.00/set
PT115K	1973-76	Trim Rings for 15 x 7-inch Honeycomb Wheels (RE)	59.00/ea.
PT115P	1973-76	Set of Four PT115K's (RE)	235.00/set

NO ADDITIONAL DISCOUNTS AVAILABLE ON TRIM RING SETS PT114P THROUGH PT115P

WHEEL STUDS



PT168W

PT168J	1960-70	Front Wheel Stud - Drum exc. 8-Lug - FS - RH thread 1/2" (RP).....	2.00/ea.
PT168L	1965-68	Front Wheel Stud - 8-Lug Drum - FS - RH thread 1/2" (RP)	Disc.
PT168N	1969-70	Front Wheel Stud - Disc -FS - RH thread 1/2" (RP)	3.00/ea.
PT168P	1969-70	Front Wheel Stud - Drum - GP 7/16" (RP)	2.00/ea.
PT168R	1969-72	Front Wheel Stud - Disc - GP 7/16" (RP)	2.00/ea.
PT168T	1971-77	Front Wheel Stud - Disc - FS 1/2" (RP)...	2.00/ea.
PT168W	1973-77	Front Wheel Stud - Disc - GP 7/16" (RP)	2.00/ea.
PT169C	1960-70	Rear Wheel Stud - FS - RH thread 1/2" (RP)	2.00/ea.
PT169E	1969-77	Rear Wheel Stud - GP 7/16" (RP).....	2.00/ea.
PT169G	1971-77	Rear Wheel Stud - FS 1/2" (RP)	2.00/ea.



PT162

PT162	1977	Aluminum Wheel Lug Nuts - 7/16" Thread (APE).....	2.50/ea.
PT162A	1977	Aluminum Wheel Lug Nut Set - 7/16" Thread (APE)	45.00/set

Quality: Very good.

VALVE STEM CAP



PT100A

PT100A	1955-77	"Correct Style" Valve Stem Cap w/ Nipple (RE).....	1.00/ea.
---------------	---------	---	----------

W
H
E
E
L
S



ENJOY THE QUALITY!

Quality has always been paramount at Ames Performance
It set us apart in 1976, in 2010, and will continue to set us apart in the future.
Don't settle for second best.

For ordering or questions, please call (800) 421-AMES (2637).
www.amesperf.com

DECALS

The decal section is divided into groups that correspond to the sections of this catalog. In other words, the first group of decals is for the interior, and so forth. Catalog sections for which there are no decals are omitted. We are not responsible for improper application of decals.

INTERIOR DECALS

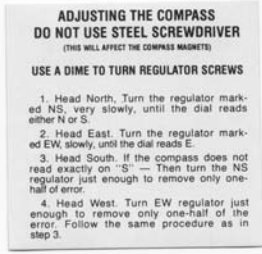

HOW TO SELECT THE PROPER GASOLINE FOR[®]
PERFORMANCE • ECONOMY • ECOLOGY

This vehicle is designed to operate on unleaded or low-lead fuels of at least 91 Research Octane. These fuels will minimize spark plug fouling and emission system deterioration. Leaded regular fuels containing more than 0.5 grams of lead per gallon normally should not be used. The engine does not require premium fuel. Therefore, its use would be an unnecessary additional expense.

If the service station gas pump has a symbol similar to the sample below, preferably use unleaded or low-lead gasoline with a symbol number of 2. A higher number is satisfactory but not required.

Ask your gasoline dealer for information on the fuel you are using both as to lead content and octane rating.

PT. NO. 339203

PX370	1955	Battery Warranty Certificate (RE)	\$4.00/ea.
PX457	1955-60	Delco Battery Owner's Certificate (RE) .	4.00/ea.
PX381	1961-64	Delco Battery Owner's Certificate (RE) .	4.00/ea.
PX382	1965-68	Delco Battery Owner's Certificate (RE) .	4.00/ea.
PX101	1955-59	Service Policy (RE).....	4.00/ea.
PX369	1960-64	Service Policy (RE).....	4.00/ea.
PX803	1959	Service Policy Envelope (RE).....	7.00/ea.
PX804	1960	Service Policy Envelope (RE).....	7.00/ea.
PX805	1961	Service Policy Envelope (RE).....	7.00/ea.
PX313	1955-59	Owner's Identification Card (RE)	4.00/ea.
PX368	1968	Owner's Identification Card (RE)	4.00/ea.
PX233	1955-58	Lighter Instruction Tag (RE).....	4.00/ea.
PX454	1955-56	Hydramatic Instruction Sunvisor Sleeve (RE).....	4.00/ea.
PX103	1955-58	Glove Box Key Decal (RE)	4.00/ea.
PX226	1955-62	Compass Glove Box Instruction Decal (RE).....	4.00/ea.



PX161	1957	Glove Box Paint Instruction Decal (RE).	4.00/ea.
PX458	1957	Lacquer Paint Instruction Card (RE)	4.00/ea.
PX698	1958-63	Power Antenna Instruction Tag (RE).....	4.00/ea.
PX936	1960-66	Seat Belt Instruction Tag (RE).....	4.00/ea.
PX117	1965	Tire Pressure Decal (RE).....	4.00/ea.
PX118	1966	Tire Pressure Decal (RE).....	4.00/ea.
PX119	1967	Tire Pressure Decal (RE).....	4.00/ea.
PX121	1968	Tire Pressure Decal (RE).....	4.00/ea.
PX450	1969	Tire Pressure Decal - GP (RE)	4.00/ea.



PX303	1971	Tire Pressure Decal - GP (RE)	3.00/ea.
PX305	1971	Tire Pressure Decal - FS (RE).....	4.00/ea.
PX333	1974	Tire Pressure Decal - KE (RE)	4.00/ea.
PX472	1974-75	Tire Pressure Decal - KE (RE)	4.00/ea.

PX158	1969-72	Ignition Lock Sunvisor Sleeve, 6" (RE) ...	\$4.00/ea.
PX452	1969-72	Ignition Lock Sunvisor Sleeve, 7" (RE) ...	4.00/ea.
PX468	1972	Seat Belt Instruction Sleeve - GP (RE)	4.00/ea.
PX405	1973-75	Ignition Lock Sunvisor Sleeve (RE).....	4.00/ea.
PX367	1973	Sunvisor Clean Air Decal (RE)	4.00/ea.
PX331	1973	Sunvisor Starting Instructions (RE).....	Disc.
PX330	1974-76	Sunvisor Starting Instructions Decal (RE)	4.00/ea.
PX308	1975-76	Push Start Warning Decal (RE)	4.00/ea.
PX610	1976-78	Hurst Modification Decal (RE)	4.00/ea.
PX162	1971-73	Vehicle Safety Maintenance Decal - FS (RE)	4.00/ea.
PX304	1971	Vehicle Safety Maintenance Decal - GP (RE)	4.00/ea.
PX158	1972-74	Fuel Recommendation Decal (RE)	4.00/ea.
PX505	1966-69	Build Sheet (RE).....	4.00/ea.
PX920	1960	New Car Pre-delivery Sheet (RE)	4.00/ea.
PX502	1968	New Car Inspection Sheet (RE).....	4.00/ea.
PX508	1969	New Car Inspection Sheet (RE).....	4.00/ea.
PX371	1970	New Car Pre-delivery Sheet (RE)	4.00/ea.
PX248	1971	New Car Pre-delivery Sheet (RE)	4.00/ea.
PX464	1972	New Vehicle Inspection Sheet (RE).....	4.00/ea.
PX477	1973	New Vehicle Inspection Sheet (RE).....	4.00/ea.
PX501	1974	New Vehicle Inspection Sheet (RE).....	4.00/ea.
PX500	1975	New Vehicle Inspection Sheet (RE).....	4.00/ea.
PX503	1976	Hurst Hatch Inspec/Warranty Sheet (RE)	4.00/ea.
PX380	1974-78	Superlift Air Shock Glove Box Card (RE)	4.00/ea.
PX536	1976	Catalytic Converter Caution Decal (RE)	4.00/ea.
PX915	1977	Catalytic Converter Caution Decal (RE)	4.00/ea.
PX465	1976-77	Headlight Dimmer Instruction Tag (RE).	4.00/ea.
PX916	1975-77	Cruise Control Instruction Tag (RE)	3.50/ea.

DOOR COMPONENT DECALS



PX186	1967	"GM Mark of Excellence" Turquoise Foil Decal, Stamped Aluminum (RE).....	5.00/ea.
PX186	1968 & Newer	"GM Mark of Excellence" Blue Foil Decal, Foil (RE)	5.00/ea.
PX810	1959	Double Sided Porcelainized Paint Treatment Decal (RE).....	Disc.

DECALS

PX175	1963-66	New Car Window Price Sticker (RE)	\$4.00/ea.
PX177	1967	New Car Window Price Sticker (RE)	4.00/ea.
PX495	1968-69	New Car Window Price Sticker (RE)	4.00/ea.
PX473	1970	New Car Window Price Sticker (RE)	4.00/ea.
PX212	1971	New Car Window Price Sticker (RE)	4.00/ea.
PX213	1972-73	New Car Window Price Sticker (RE)	4.00/ea.
PX620	1974	New Car Window Price Sticker (RE)	4.00/ea.
PX609	1977-79	New Car Window Price Sticker (RE)	4.00/ea.
PX926	1969-74	Vehicle Certification Decal Kit (RE)	Disc.
PX946	1975	Vehicle Certification Decal Kit (RE)	12.00/ea.
PX927	1976-77	Vehicle Certification Decal Kit (RE)	12.00/ea.

CONVERTIBLE TOP DECALS

PX155	1970-73	Convertible Top Bracket Decal (RE).....	4.00/ea.
--------------	---------	---	----------

TRUNK COMPONENT DECALS



PX126



PX140A

PX494	1958	Jack Instructions (RE)	4.00/ea.
PX140	1960	Jack Instructions (RE)	Disc.
PX140A	1960	Trunk Water Test Inspection Decal (RE)	4.00/ea.
PX166	1961	Jack Instructions (RE)	4.00/ea.
PX133	1962	Jack Instructions (RE)	4.00/ea.
PX134	1963	Jack Instructions (RE)	4.00/ea.
PX113	1964	Jack Instructions (RE)	4.00/ea.
PX511	1962-64	Jack Base Decal (Caution) (RE)	4.00/ea.
PX942	1964	Jack Hook Decal (RE)	4.00/ea.
PX125	1965	Jack Instructions (RE)	4.00/ea.
PX126	Early 1966	Jack Instructions exc. CVT (RE)	4.00/ea.

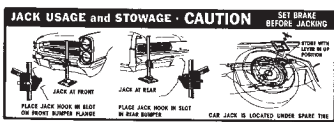

PX623



PX624

PX623	Late 1966	Jack Instructions exc. CVT (RE)	4.00/ea.
PX624	Late 1966	Jack Instructions, CVT (RE)	4.00/ea.
PX111	1967	Jack Usage Instructions (RE)	4.00/ea.
PX112	1967	Jack Stowage Instructions exc. CVT (RE)	4.00/ea.
PX312	1967	Jack Stowage Instructions - CVT (RE)	4.00/ea.
PX217	1968	Jack Instructions - All exc. CVT (RE).....	4.00/ea.
PX529	1968	Jack Stowage Instructions - CVT (RE)	4.00/ea.
PX385	1969	Jack Instructions - GP (RE)	4.00/ea.
PX921	1970	Jack Instructions - GP (RE)	4.00/ea.
PX147	1971-72	Jack Instructions - GP (RE)	4.00/ea.
PX151	1973	Jack Instructions - GP (RE)	4.00/ea.
PX154	1974-77	Jack Instructions - GP (RE)	4.00/ea.
PX625	1973	Jack Instructions - Grandville CVT (RE) .	4.00/ea.
PX335	1955	Jack Base Decal (RE)	4.00/ea.
PX310	1956-57	Jack Head Decal (RE)	4.00/ea.
PX178	1957	Jack Base Decal (RE)	4.00/ea.
PX240	1959	Jack Decal (RE)	4.00/ea.
PX372	1959-61	Jack Base Decal (RE)	4.00/ea.

CAUTION
BEFORE USING JACK, PULL THE "CAR LIFT" CONTROL TO THE FULL OUT POSITION. CONTROL IS LOCATED TO THE LEFT SIDE OF THE STEERING COLUMN ON THE LOWER SURFACE OF THE INSTRUMENT PANEL.

PX229

PX229	1958	Air Suspension Decal (RE)	\$4.00/ea.
PX359	1971-74	Air-Shock Decal (RE)	4.00/ea.
PX286	1975-78	Air-Shock Decal (RE)	4.00/ea.
PX332	1973-77	Space Saver Inflator Bottle Decal (RE)	4.00/ea.
PX326	1973-77	Space Saver Spare Warning Decal (RE)	4.00/ea.
PX595	1977	Space Saver Spare Warning Decal (RE)	4.00/ea.
PX324	1976-77	Anti-Spin Trunk Decal (RE)	4.00/ea.
PX306	1977	Aluminum Wheel Warning Decal (RE)	4.00/ea.

FUEL USAGE DECALS

UNLEADED GASOLINE ONLY

PX109Z

PX108Z	Unleaded Gasoline Only 5" Straight, White(RE) ..	4.00/ea.
PX109Z	Unleaded Gasoline Only 5" Straight, Black(RE)...	4.00/ea.
PX113Z	Unleaded Gasoline Only 5" Straight, Black-White(RE).....	4.00/ea.
PX112Z	Unleaded Fuel Only 4" Straight, Black-Silver(RE)	4.00/ea.
PX110Z	Unleaded Fuel Only 3" Curved, White(RE)	4.00/ea.
PX111Z	Unleaded Fuel Only 3" Curved, Black(RE)	4.00/ea.

ELECTRICAL RELATED

PX172	1963-67	Transistor Ignition Coil Decal (RE)	4.00/ea.
PX173	1963-66	Transistor Amplifier Decal (RE)	4.00/ea.
PX614	1967	Transistor Amplifier Decal (RE)	4.00/ea.
PX336	1963-67	Breakerless Ignition Decal (RE)	4.00/ea.

ENGINE COMPONENT & COMPARTMENT DECALS



PX228

PX348	1955	2 BBL Air Cleaner Service Decal (RE) ...	4.00/ea.
PX132	1955-57	4 BBL Air Cleaner Service Decal w/Oil Bath Air Cleaner (RE)	4.00/ea.
PX378	1956	2 BBL Oil-Bath Air Cleaner Decal (RE) .	4.00/ea.
PX131	1957	Air Cleaner Service Decal w/Paper Element (RE)	4.00/ea.
PX554	1957	Tri-Power Air Cleaner Service Decal (RE)	4.00/ea.
PX347	1958-60	4 BBL and 1958 2 BBL Air Cleaner Decal (RE)	4.00/ea.
PX350	1959-60	Tri-Power Air Cleaner Service Decal w/ A59C element (RE)	4.00/ea.
PX555	1958	Tri-Power Air Cleaner Service Decal (RE)	Disc.
PX349	1959-64	Air Cleaner Service Instruction Decal, Red w/A96C (RE)	4.00/ea.
Use this decal with foam and screen element.			
PX580	1959-64	Air Cleaner Service Instruction Decal, White w/A96C (RE)	4.00/ea.
Use this decal with foam and screen element.			
PX196	1962-63	421 HO Air Cleaner Decal (RE)	5.00/ea.



		PX197	
PX197	1962-63	421 SD Air Cleaner Decal (RE).....	\$5.00/ea.
PX198	1962-63	421 GP Air Cleaner Decal (RE).....	5.00/ea.
PX705	1963-64	389 Air Cleaner Service Decal w/ A96C (RE)	4.00/ea.
PX150	1964	Tri-Power Air Cleaner Service Decal (RE)	4.00/ea.
PX556	1965	389 Tri-Power & Police 421 Air Cleaner Service Decal (RE)	4.00/ea.
PX557	1965	Calif. 389 Tri-Power & Police 421 Air Cleaner Service Decal (RE)	4.00/ea.
PX558	1965	421 Tri-Power Non-Police Air Cleaner Service Decal (RE)	4.00/ea.
PX559	1965	Calif. 421 Tri-Power Non-Police Air Cleaner Service Decal (RE)	4.00/ea.
PX159	1965-66	389/421 Air Cleaner Service Decal w/A96C (RE)	4.00/ea.
		Use this decal with foam and screen element.	
PX170	1965-70	Air Cleaner Service Decal w/A98 (RE) ..	4.00/ea.
		Use with pancake filter only.	
PX917	1967	Air Cleaner Service Decal - GP (RE).....	4.00/ea.
PX210	1968	350 - 2 BBL Air Cleaner Service Decal w/A331C (RE)	4.00/ea.
PX183	1968-69	2 BBL Heavy Duty Air Cleaner Service Decal w/A277C (RE).....	4.00/ea.
PX184	1968	400 - 4 BBL Air Cleaner Service Decal (RE).....	4.00/ea.
PX182	1968	428 - 4 BBL Air Cleaner Service Decal exc. GP (RE)	4.00/ea.
PX886	1968-69	428 - 4 BBL Air Cleaner Service Decal - GP (RE)	4.00/ea.
PX228	1967-70	Keep Your GM Car All GM Air Cleaner Decal (RE)	4.00/ea.
PX383	1971	Keep Your GM Car All GM Air Cleaner Decal (RE)	4.00/ea.
PX455	1972-73	V8 - 2 BBL Keep Your GM Car All GM Air Cleaner Decal (RE)	4.00/ea.
PX439	1972-73	V8 - 4 BBL Keep Your GM Car All GM Air Cleaner Decal (RE)	4.00/ea.
PX328	1974	Keep Your GM Car All GM Air Cleaner Decal (RE)	4.00/ea.
PX440	1975	Keep Your GM Car All GM Air Cleaner Decal exc. 455 (RE)	4.00/ea.
PX622	1975	Keep Your GM Car ALL GM Air Cleaner Decal - 455 (RE)	4.00/ea.
PX441	1976	Keep Your GM Car All GM Air Cleaner Decal (ALL exc. 400 engine) (RE).....	4.00/ea.
PX534	1976	Keep Your GM Car All GM Air Cleaner Decal (400-FS) (RE).....	4.00/ea.
PX604	1976	Keep Your GM Car All GM Air Cleaner Decal (400-GP) (RE)	4.00/ea.
PX582	1977	Keep Your GM Car All GM Air Cleaner Decal (400-4V) (RE).....	4.00/ea.
PX593	1977	Keep Your GM Car All GM Air Cleaner Decal 2BBL (RE)	4.00/ea.
PX171	1970	Regular Fuel Engine Valve Cover Decal (RE).....	4.00/ea.
PX104	1955-58	AC Oil Filter Decal (RE).....	4.00/ea.
PX309	1955-60	Oil Filter Decal (RE).....	4.00/ea.

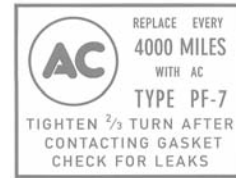

		PX309A	
PX309A	1960-67	PF7 Oil Filter Decal (RE)	\$4.00/ea.
		This decal can be used on spin-on oil filters to make them look original.	
PX311	1955-57	Oil Filler Cap Decal Pink (RE)	4.00/ea.
PX438	1955-57	Oil Filler Cap Decal Orange (RE)	4.00/ea.
PX311A	1958-60	Oil Filler Cap Decal (RE).....	4.00/ea.
PX234	1955-63	Generator Warning Tag (RE).....	4.00/ea.
PX532	1960	Caution Fan Decal (RE)	4.00/ea.
PX533	1961	Caution Fan Decal (RE)	4.00/ea.



		PX115	
PX115	1962-63	Caution Fan Decal (Horiz.) (also '64 GP) (RE)	4.00/ea.
PX143	1962-63	Caution Fan Decal (Vert.) (RE).....	4.00/ea.
PX114	1964	Caution Fan Decal (RE)	4.00/ea.
PX128	1965-66	Caution Cooling Decal (RE)	4.00/ea.
PX129	1967-68	Caution Cooling Decal (RE)	4.00/ea.
PX144	1970-72	Caution Cooling Decal (RE)	4.00/ea.
PX157	1973	Caution Cooling Decal (RE)	4.00/ea.
PX285	1974-78	Engine Coolant Decal (RE).....	4.00/ea.
PX469	1963	Caution Radiator Cap Decal - GP (RE) ..	4.00/ea.
PX116	1963-65	Battery Warning Decal (RE)	4.00/ea.
PX187	1955-56	Power Steering Lid Decal (RE)	4.00/ea.
PX188	1955-56	Power Steering Pulley Decal (RE)	4.00/ea.
PX506	1955-60	Methanol Anti-Freeze Tag (RE)	4.00/ea.
PX142	1964-65	Anti-Freeze Tag (RE)	4.00/ea.
PX287		GM Dealer Installed Anti-Freeze Decal (RE).....	4.00/ea.



		PX287A	
PX287A	1957-66	GF-61-P Fuel Filter Decal (RE)	4.00/ea.
		Make your afterproduct fuel filter look like original with this correctly printed decal.	
PX203	1957	Paint Finish Decal (RE)	4.00/ea.



		PX105	
PX105	1955-58	Trico Windshield Washer Decal (RE)	4.00/ea.
PX351	1955-60	GM Windshield Washer Bracket Decal (RE).....	4.00/ea.
PX352	1961-63	GM "Kleer-view" Windshield Washer Label (RE)	4.00/ea.

DECALS

4. Do not use in GM cars until 1988 model year. Use only on GM cars with GM electrical systems. Do not use on cars with other electrical systems. Do not use on cars with other electrical systems.

5. Do not use in GM cars until 1988 model year. Use only on GM cars with GM electrical systems. Do not use on cars with other electrical systems. Do not use on cars with other electrical systems.

6. Do not use in GM cars until 1988 model year. Use only on GM cars with GM electrical systems. Do not use on cars with other electrical systems. Do not use on cars with other electrical systems.

General Motors Approved
 Optikleen®
 Windshield Washer Solvent

CAUTION: KEEP CHILDREN OFF THIS PRODUCT. DO NOT USE IN THE NEARBY OF OPEN FLAMES OR FIRE. DO NOT USE IN THE NEARBY OF OPEN FLAMES OR FIRE.

ANTIFOULING: If antifoulant is recommended by manufacturer, use recommended amount. Do not use more than recommended amount. Do not use less than recommended amount. Do not use more than recommended amount. Do not use less than recommended amount.

DANGER: FLAMMABLE. VAPOR HARMFUL. MAY BE IRRITANT OR CAUSE BLINDNESS IF SWALLOWED.

NOT FOR RESALE

CAUTION: FOR WINTER USE ONLY. THE FOLLOWING QUANTITIES OF Solution are applied to the Windshield to reduce freezing action. In freezing temperatures, the Solution has been formulated to prevent windshield freezing.

KEEPER-VIEW® WINDSHIELD WASHER ANTI-FREEZE and BUG REMOVER

FOR REPLACEMENT OF WINDSHIELD WASHER FLUID, INSURE THAT NUMBER 112121 OF 982111 APPLIES TO YOUR MODEL. GENERAL MOTORS CORPORATION

CAUTION: FOR SUMMER USE. Add a splash of Solution to Washer Reservoir. Top off with water for improved cleaning.

CAUTION: FLAMMABLE MIXTURE. DO NOT USE NEAR FIRE OR FLAME.

VEHICLE EMISSION CONTROL INFORMATION

PONTIAC MOTOR DIVISION GENERAL MOTORS CORP.

SEE SERVICE MANUAL FOR ADDITIONAL INFORMATION

	PX355	1964-67 GM Optikleen Windshield Washer Label (RE)	4.00/ea.
	PX353	1968-72 GM Windshield Washer Bottle Label (RE)	4.00/ea.
	PX361	1964-67 GM "Pontiac Klee-view" Windshield Washer Label.....	4.00/ea.
	PX497	1960 Heater Box Inspection Decal (under hood) (RE)	4.00/ea.
	PX470	1963 Air Conditioner Compressor Belt Instruction Decal (RE).....	4.00/ea.
	PX937	1960-69 Freon Charge Air Compressor Tag (RE) .	4.00/ea.
	PX149	1957-65 Air Compressor Warning Decal (RE).....	4.00/ea.
	PX204	1964-65 Frigidaire Air Compressor Decal (RE) ...	4.00/ea.
	PX205	1966 Frigidaire Air Compressor Decal (RE) ...	4.00/ea.
	PX206	1967 Frigidaire Air Compressor Decal (RE) ...	4.00/ea.
	PX207	1968-70 Frigidaire Air Compressor Decal (RE) ...	4.00/ea.



	PX208	1971 Frigidaire Air Compressor Decal (RE) ...	4.00/ea.
	PX209	1972 Frigidaire Air Compressor Decal (RE) ...	4.00/ea.
	PX215	1973 Frigidaire Air Compressor Decal (RE) ...	4.00/ea.
	PX236	1974 Frigidaire Air Compressor Decal (RE) ...	4.00/ea.
	PX594	1977 Delco Air Compressor Decal (RE)	4.00/ea.
	PX314	1965 Harrison AC Evaporator Decal (RE)	4.00/ea.
	PX315	1966 Harrison AC Evaporator Decal (RE)	4.00/ea.
	PX316	1967 Harrison AC Evaporator Decal (RE)	4.00/ea.
	PX317	1968 Harrison AC Evaporator Decal (RE)	4.00/ea.
	PX318	1969 Harrison AC Evaporator Decal (RE)	4.00/ea.
	PX319	1970 Harrison AC Evaporator Decal (RE)	4.00/ea.
	PX320	1971 Harrison AC Evaporator Decal (RE)	4.00/ea.
	PX321	1972 Harrison AC Evaporator Decal (RE)	4.00/ea.
	PX322	1973 Harrison AC Evaporator Decal (RE)	4.00/ea.
	PX375	1974 Harrison AC Evaporator Decal (RE)	4.00/ea.
	PX376	1975 Harrison AC Evaporator Decal (RE)	4.00/ea.
	PX377	1976 Harrison AC Evaporator Decal (RE)	4.00/ea.
	PX596	1977 New Refrigerant AC Evaporator Decal (RE).....	4.00/ea.



	PX600	1969 Cruise Control Transducer Decal (RE)...	4.00/ea.
	PX913	1966-67 California Air Injection Reactor Decal (RE).....	4.00/ea.

	PX139	1968 350-2V Emission Decal (RE)	4.00/ea.
	PX138	1968 400-2V Emission Decal (RE)	4.00/ea.
	PX168	1968 350-4V, 428-4V Emission Decal (RE).....	4.00/ea.
	PX939	1968 400-4V Emission Decal (RE)	4.00/ea.
	PX890	1969 All 2 bbl V8 Emission Decal (RE).....	4.00/ea.
	PX891	1969 All 4 bbl V8 Emission Decal (RE).....	4.00/ea.
	PX192	1970 All 2 bbl V8 Emission Decal (RE).....	4.00/ea.
	PX185	1970 All 4 bbl V8 Emission Decal exc. 455 (RE).....	4.00/ea.
	PX239	1970 455-4V Emission Decal (RE)	4.00/ea.
	PX379	1971 400-4V AT Emission Decal (RE)	4.00/ea.
	PX200	1971 400-4V MT Emission Decal (RE)	4.00/ea.
	PX689	1971 350-2V AT/MT Emission Decal (RE)	4.00/ea.
	PX357	1972 350 AT Emission Decal (RE).....	4.00/ea.
	PX167	1972 400-2V AT Emission Decal, exc. GP (RE).....	4.00/ea.
	PX202	1972 400-4V Emission Decal (RE)	4.00/ea.
	PX201	1972 455-4V Emission Decal (RE)	4.00/ea.
	PX530	1972 400-2V Emission Decal - GP (RE).....	4.00/ea.
	PX524	1973 400-AT Emission Decal (RE)	4.00/ea.
	PX553	1973 400-MT Emission Decal (RE)	4.00/ea.
	PX528	1973 455-AT Emission Decal (RE)	4.00/ea.
	PX245	1973 455-MT Emission Decal (RE)	4.00/ea.
	PX327	1974 350-AT Emission Decal (RE)	4.00/ea.
	PX302	1974 350-MT Emission Decal (RE)	4.00/ea.
	PX241	1974 400-AT Emission Decal (RE)	4.00/ea.
	PX230	1974 400-MT Emission Decal (RE)	4.00/ea.
	PX531	1974 455-AT Emission Decal (RE)	4.00/ea.
	PX957	1975 400-4V AT Emission Decal (RE)	5.00/ea.
	PX929	1975 350-4V AT Emission Decal (RE)	5.00/ea.
	PX496	1976 400-AT Emission Decal (RE)	4.00/ea.
	PX611	1976 400-MT Emission Decal (RE)	4.00/ea.
	PX525	1976 455-MT Emission Decal (RE)	4.00/ea.
	PX523	1977 400-AT Emission Decal w/Perf. Option (RE)	4.00/ea.
	PX922	1977 400-MT Emission Decal (RE)	5.00/ea.

AFTERMARKET AIR CLEANER & VALVE COVER DECALS



	PX412	326-2V Air Cleaner Decal (AP)	5.00/ea.
	PX407	326-4V Air Cleaner Decal (AP)	5.00/ea.
	PX408	350-2V Air Cleaner Decal (AP)	5.00/ea.
	PX409	350-4V Air Cleaner Decal (AP)	5.00/ea.
	PX410	389-2V Air Cleaner Decal (AP)	5.00/ea.
	PX411	389-4V Air Cleaner Decal (AP)	5.00/ea.
	PX412	400-2V Air Cleaner Decal (AP)	5.00/ea.
	PX413	400-4V Air Cleaner Decal (AP)	5.00/ea.
	PX414	421-4V Air Cleaner Decal (AP)	5.00/ea.
	PX416	428-4V Air Cleaner Decal (AP)	5.00/ea.
	PX417	455-4V Air Cleaner Decal (AP)	5.00/ea.
	PX418	455-4V Hi Perf. Air Cleaner Decal (AP)	5.00/ea.
	PX419	Pontiac 389 Ram Air 360 HP Valve Cover Decal (AP)	4.00/ea.
	PX732	Pontiac 421 Tri-Power 425 HP Valve Cover Decal (AP)	4.00/ea.
	PX354		

DECALS

INDEX

-A-

A/C Components.....	162-165
A/C Seal Kit.....	164,165,169
A/C Vent Deflector.....	40
Accelerator Linkage.....	133
Accessory Floor Mats.....	26
Adhesive:	
Headliner.....	43
Weatherstrip.....	96
A-frame Seals.....	168-169
Air Cleaners.....	125
Air Filter Elements.....	124
Air Filter Recharge Kit.....	124
Air Horn Repair Kits.....	125
Alternator Brackets.....	139
Alternator Related.....	114,139,146
Antenna Components.....	109-110
Anti-Freeze Tester.....	162
Anti-Sway Bar Kits.....	204-205
Apparel.....	7
Armrest Pads & Bases.....	23-25
Armrest Panels- Convertible.....	24
Ash Tray.....	25
Assembly Manual.....	12
ATC Components.....	166
Axle Tags.....	198
Axle Vent Tube.....	198

-B-

B-Pillar Panels.....	92
Backing Plates.....	193
Backlock Components.....	177
Batteries.....	115
Battery Cables.....	115-116
Battery Float Charger.....	115
Battery Tray & Components.....	159-160
Bearing Kit - Rear End.....	198
Belts, Engine.....	143
Blower Motor Case.....	165
Blower Motors.....	165
Blower Motor Resistors.....	164
Blower Motor Switches.....	165
Bolt Kits:	
A-Frame.....	201
Bell Housing to Block.....	180
Body Mount.....	209
Bucket Seat.....	20
Carburetor.....	125,133
Connecting Rod.....	157
Core Support.....	209
Crossmember.....	182
Door Hinge.....	63
Engine Head.....	154
Exhaust Manifold.....	144-145
Fan.....	168
Fan Shroud Top Plate.....	167
Flywheel.....	179
Flywheel Cover.....	180
Front End.....	53
Fuel Pump.....	127
Hood Hinge.....	58
Hood Latch.....	59
Intake Manifold.....	138
Oil Pan.....	153
Pressure Plate to Flywheel.....	179
Rear End Cover.....	198
Seat Belt.....	20
Shock.....	206
Starter.....	146
Steering Box.....	202
Thermostat Housing.....	140
Timing Chain Cover.....	141
Torque Converter Cover.....	180
Transmission.....	180
Transmission Oil Pan.....	175
Valve Cover.....	122
Water Pump.....	141

Body Mounts.....	207-208
Body Plugs.....	30,91,170
Body Side Molding Clips.....	56,75,91
Brake Booster Components.....	185
Brake Boosters.....	185-186
Brake Calipers.....	195
Brake Line Clips.....	187-188
Brake Lines.....	188-190
Brake Line Tubing & Shielding.....	188
Brake Pads.....	193
Brake Pedal Pads.....	171
Brake Repair Kits.....	191-192
Brake Shoes.....	192-193
Brake Drums.....	192-193
Breakers.....	112
Bucket Seat Panels.....	17-18
Bumper Bolts.....	53,108
Bumper Stop Kits.....	8

-C-

Caliper Lines.....	189
Caliper Mounting Brackets.....	195
Camshafts.....	155-156
Cancel Cams.....	111
Caps, Wheel Center.....	210-214
Caps, Wheel Grease.....	197
Carburetors.....	130-131
Carburetor Fittings.....	135
Carburetor Floats.....	133
Carburetor Jets.....	132
Carburetor Rebuilding Kit.....	131
Car Care Products.....	5-7,84
Car Covers.....	4
Car Jackets.....	4
Carpets.....	27-28
Center Cap Locks.....	211
Choke Components.....	134
Choke Lines.....	135
Choke Pull-Offs.....	134
Cigarette Lighters.....	39
Clamps.....	127,166
Climate Control Cables.....	165
Clips - Steel Line.....	129,187-188
Clocks - Display.....	8
Clutch Components.....	179-181
Clutch Kits.....	179
Clutch Pedals & Components.....	180-181
Coat Hooks.....	45
Coil - Ignition.....	147
Coil Brackets.....	147
Coil Springs.....	206-207
Column Shift Components.....	176
Console Components.....	40-41
Console Inserts.....	36-37
Control Arm Components.....	200-201
Converter & Flywheel Covers.....	180
Convertible Armrest Bezels.....	45
Convertible Armrest Covers.....	24
Convertible Armrest Panels.....	24
Convertible Top Cleaner.....	84
Convertible Top Components.....	82-86
Convertible Top Switches.....	39,85
Coolant Additive.....	162
Core Support Mounting Kits.....	209
Cowl Drain Gutter.....	58
Cowl Grilles & Screens.....	57
Cowl Panel Drains & Plugs.....	80
Cowl Seals.....	58
Cylinder Heads.....	154

-D-

Dash Circuits.....	116
Dash Inserts.....	35-37
Dash Insulation.....	30
Dash Knobs & Components.....	38-39
Dash Pads & Covers.....	34
Dash Pots.....	137

Decals.....	4,23,170,215-218
Deck Lid Arrowheads.....	100
Deck Lid Latch.....	98
Dipsticks & Tubes.....	152,175
Disc Brake Spindle Kit.....	195
Distributor Caps.....	147
Distributors.....	146
Distributor Tag Fasteners.....	146
Dome Lamp Components.....	45-46
Door Badges.....	62
Door Components.....	61-77
Door Handles & Gaskets.....	61-62
Door Handle Reinforcements.....	77
Door Handle Shields.....	62
Door Hinges - Front Door.....	63
Door Jamb Edging.....	45
Door Jamb Louvers.....	91
Door Jamb Reinforcement.....	92
Door Panels.....	21-22
Door Panel Carpeting.....	23
Door Panel Fasteners.....	22
Door Panel Watershields.....	23
Door Patch Panels.....	77
Door Sill Plates.....	75
Door Skins.....	77
Door Strikers.....	64
Door Window Stops.....	64
Drain Plugs.....	30,91,99,153
Drain Seals - Door.....	64
Drip Rail Moldings - Front.....	78
Dusters.....	6
Dynamat©.....	7

-E-

Edelbrock© Components.....	131,138,154,156
Electrical Related.....	109-119
Emblems:	
Console.....	41
Deck Lid.....	100-101
Door.....	62
Front End.....	48-49
Front Fender.....	54-55
Grille.....	49
Hood.....	57
Horn Button.....	31
Instrument Panel.....	40
Radiator Shroud.....	167
Rear 1/4.....	87-88
Tail Panel.....	100-101
Engine Bearings.....	157
Engine Belts.....	143
Engine Compartment	
Components.....	159-170
Engine Components.....	120-158
Engine Cradle.....	151
Engine Gasket Sets.....	158
Engine Mounts.....	151
Exhaust Manifold	
Components.....	144-145
Exhaust Manifold Coating.....	120,144
Exhaust Hangers & Clamps.....	103
Exhaust System.....	145

-F-

Fan Clutch.....	168
Fan Shrouds and Guards.....	167
Fender Covers.....	4
Fender Shims.....	56
Firewall Pads.....	30
Firewall Plugs & Grommets.....	165,170
Firewall Wiring Harness Gutter.....	169
Flex Hose.....	1961
Flexplates.....	179
Flipper Components - Door.....	70
Floor Insulation.....	28
Floor Pans & Braces.....	28-29
Flowmaster Mufflers.....	145

Flywheel & Converter Covers	180
Flywheels.....	179
Frame Repair Kit	209
Freeze Plugs.....	158
Front End Trim.....	48-53
Front Fender Components.....	54-56
Fuel & Vacuum Line Clamps.....	127
Fuel Filters.....	129
Fuel Gauge Sending Unit.....	106
Fuel Hose.....	127
Fuel Injection Grommet Kit	170
Fuel Lines	126-129
Fuel Line Clips	129
Fuel Line Tubing.....	129
Fuel Pump.....	127
Fuel Pump Eccentric	156
Fuel Tanks & Insulation	106
Fuel Tank Repair Kits	5
Fuses.....	112

-G-

Gas Doors.....	107
Gas Gauge Sending Units.....	106
Gas Hose	127
Gas Lines.....	126-129
Gas Line Clips.....	129
Gas Line Tubing.....	129
Gas Tanks	106
Gas Tank Insulation	106
Gas Tank Straps	107
Gaskets:	
Axle Flange.....	193
Brake Backing Plate.....	193
Carburetor	133
Carb to Air Cleaner.....	125
Distributor	147
Door Handle and Lock.....	62
Exhaust Manifold	145
Fender Skirt to Body	92
Fuel Pump	127
Head	154,158
Heater Box	165
Hood Tach	59
Intake Manifold	138
Muncie 4-Speed	177
Oil Pan	153
Overhaul Sets	158
Rear End Cover.....	198
Rear Main.....	158
Tailshaft	177
Thermostat.....	140
Timing Chain Cover	141
Valley Pan	138
Valve Cover.....	122
Water Pump	140
Generator Tag Fasteners	114,146
Glass Channel Guide Plates & Staples.....	71
Glove Boxes.....	34
GM Vehicle Care & Shop Products.....	5,148,157,177,185,198
Grant Steering Wheels	33
Grease Caps.....	197
Ground Straps.....	168

-H-

Harmonic Balancers	158
Hats.....	7
Hazard Light knobs & Flashers	111
Headers	144
Headlight Components.....	49-51
Headlight Door Components.....	49
Headliners	43
Headliner Sound Deadener	43
Headrests	19
Heater Control Valves.....	164
Heater Cores	165
Heatshield:	
Battery Cable.....	146
Starter Solenoid	146

Hoggrings and Pliers.....	17
Hood Components	57-60
Hood Hinges & Components.....	58
Hood to Windshield Frame Pad	58
Horns and Relays.....	114
Hose Clamps	127,166
Hurst Pit Pack	177

-I-

Idle Stop Solenoid & Brackets.....	137
Ignition Components	150
Ignition Switches	112-113
Inner Fenderwell Nuts	56
Inner Panel Water Shield	23
Instrument Cluster Lens.....	34
Instrument Panel Script.....	40
Insulation, Underhood.....	60
Intake Manifolds & Components	138
Interior Paint	14

-J-

Jack Packs & Components	95
Joe Gibbs Oil	151
Junction Blocks	114
Junction Block Starter Cables.....	116

-K-

Keys:	
Console	98
Door.....	113-114
Glove Box.....	98
Ignition.....	113-114
Trunk	98
Key Chains.....	7
Kick Panels & Components.....	41
K & N Air Filters.....	124

-L-

Lamp Kit:	
Console	40
Glove Box.....	34
License Plate.....	108
Underhood.....	59
Trunk	97
Lenses:	
Back-up	105
Console Courtesy	3340
Interior Lamp	46
Rear 1/4 Side Marker.....	88
Side Marker	53
License Lamp.....	108
Parking Light.....	522
Shift Indicator	40
Taillight.....	104
License Lamp Components.....	108
License Plates.....	8
Lifters	156
Light Bulbs	112
Line Clips	129,187-188
Light Sockets	116
Literature	10-13
Lock Pillar Weatherstrip.....	91
Lock Pulls & Ferrules.....	69-70
Locks:	
Console	40
Door.....	62-63,113
Glove Box.....	35
Ignition	113
Trunk	98
Lock Sets.....	9
Lug Nuts	210-214

-M-

Main Bearing Caps	157
Manifolds:	
Exhaust	144
Intake.....	138
Master Cylinder Components.....	182-184
Mirror Components	47,65-66
Mity Mount©	151

Moldings:	
Rear Window Reveal.....	78
Rocker Panel	76
Windshield Reveal	78
MSD Performance Ignition©.....	150
Muncie Transmission Components.....	178

-O-

Oil Breather Caps.....	122-123
Oil Dipsticks & Tubes.....	152
Oil Filters	151
Oil Filter Adapters.....	151
Oil Pans	153
Oil Pumps.....	157

-P-

Package Trays.....	42-43
Padded Dashes	34
Paint:	
Chassis	159,209
Engine.....	120
Engine Compartment.....	120,159
Interior Paint	14
POR-15© Products.....	5,33,107,209
Radiator	159
Shock Absorber Paint	206
Trunk Spatter.....	96-97
Wheel.....	210,212
Parking Brake Components	187
Parking Light Components	52-53
Patch Panels:	
Floor.....	48-29
Rear Window	108
Trunk	99
PCV Components	137
PCV Hose	137
Pedal Pads and Trim.....	171-172
Pertronix Ignition	150
Piston Rings.....	157-158
Plastigage©.....	157
Points	146
POR15 Products.....	5,33,107,209
Posi-Traction Carriers.....	197
Posters.....	8
Power Antenna Components.....	109-110
Power Antenna Switch & Bezels.....	39
Power Steering Boxes	201-202
Power Steering Hoses	202
Power Window Motors	68,89
Power Steering Pumps	202
Pre-Heater Components	145
Printed Circuits	116
Proportioning Valves	185
Pulley Sets.....	142
Pushrods & Guideplates	155

-R-

Radiator Caps	162
Radiator and Heater	
Hoses and Clamps.....	166
Radiators	160-161
Radiator Support Baffles.....	53
Radio Components.....	38-39
Radios.....	110
Radio Speaker Components	43,110,113
Rally II Wheels	211-212
Rear Control Arms	203
Rear End Bearing Kit.....	198
Rear End Components	198
Rear End Trim.....	100-108
Rear Glass Channel & Drains	80
Rear Main Seals	158
Rear Seat Divider Panel.....	95-96
Rear Seat Padding.....	17
Rear Window Panels	108
Rear 1/4 Trim.....	87-92
Rearview Mirrors and	
Components.....	47,65-66
Relays	112
Remote Mirror Components	23,66

Reverb & Speaker Bezels	39
Rocker Arms	155
Rocker Panel Components	76-77
Rubber Bumpers:	
Seat	19
Console	41
Control Arm.....	200
Door	64
Gas Door.....	107
Glove Box.....	35
Hood	58
Kits.....	8
Rear Axle.....	200
Trunk	97

-S-

Sash Channels & Screws	73,90
Screw Kits:	
Armrest	25
Convertible Top.....	82
Door Sill Plate.....	75
Headlight Adjusters	51
Interior	45
Vent Window	75
Wheelwell Molding.....	56
Window Frame.....	74
Window Track.....	74
Seals:	
Air Conditioner	165,168-169
Clutch Rod	180
Heater Box	165
Rear Body Panel to Bumper	108
Rear Main	158
Shift Lever.....	172
Splash.....	168-169
Steering Column.....	30
Tail Shaft.....	177
Wheel Bearing.....	197
Seam Sealer	30,92,99
Seat Belts & Components	20-21
Seat Brackets.....	20
Seat Components.....	15-21
Seat Frames.....	17
Seat Padding	17
Seat Piping	18
Seat Springs.....	16
Seat Tracks.....	20
Seat Upholstery	15-16
Sending Units:	
Oil Pressure	113
Temperature	113
Gas Gauge.....	106
Shift Cables	174
Shift Knobs	173
Shift Porches	172
Shifter Plate	176
Shock Absorbers	205
Shop Manuals	12-13
Side Marker Lamp Components	53,88
Spare Tire Covers.....	95
Spark Plugs	149
Spark Plug Wires, Looms and Brackets.....	148-149
Speakers	110,113
Speaker Enclosures	113
Speaker Grilles.....	43
Speed Bleeders	195
Speedometer Cables	176
Spindle Components.....	195
Splash Seals	168-169
Spotweld Cutter	5
Springs:	
Clutch	181
Coil	206-207
Hood Hinge.....	58
Throttle	135
SSBC	196
Stabilizer Bars	203,204
Starters	146

Starter Solenoids	146
Starter Tag Fasteners	114,146
Steel Line Clips.....	129,187-188
Steering Box	201-202
Steering Column Cancel Cam.....	111
Steering Column	31
Steering Column Plate	30
Steering Column Seals	30
Steering Couplers.....	203
Steering Wheel Components & Assemblies	31-33
Studs, Wheel.....	214
Suspension & Steering Components.....	199-209
Sunshade Components	44
Sway Bar Kits.....	204-205
Switches:	

Back-up Light	173
Blower Motor	165
Convertible Top.....	39,85
Directional Signal	111
Door Jamb	65
Headlight.....	111
Headlight Dimmer.....	111
Ignition.....	112-113
Neutral Safety	111
Oil Pressure	113
Power Antenna	39
Power Window	25
Stop Light.....	112
Temperature	113
Thermostatic Vacuum	136
Transmission Kickdown.....	112
Trunk Release.....	97
Windshield Wiper	81

-T-

T-Shirts	7
Tachometers	34,59
Tailgate Components.....	102
Taillight Lenses	104
Tailpipe Extensions	103
Tailshaft Output Seal.....	176
Thermostat Housings.....	139-140
Thermostatic Vacuum Control Switch	136
Throttle Components.....	134-135
Tilt Levers.....	31
Timing Chain Sets	156
Timing Chain Cover & Components.....	141
Traction Bars.....	205
Transmission Cooling Lines.....	174-175
Transmission Crossmembers.....	182
Transmission Filter Kits	175
Transmission Mounts.....	182
Transmission Oil Pans	175
Transmission Rebuild Kits.....	177
Transmission Vacuum Lines	175
Trim Adhesive.....	43
Trim Rings	210,212,214
Tri-Power Components	123-126,130-136,139
Trunk Components	93-99
Trunk Floors.....	99
Trunk Mats	93-94
Trunk Side Panels	94-95
Trunk Spatter Paint	96-97
Turn Signal Levers.....	31

-U-

Underdash Insulation.....	30
Underhood Insulation.....	60
Universal Joints	197
Urethane Suspension Components	200-201,203,204,205

-V-

V-Belts	143
Vacuum & Fuel Line Clamps	127
Vacuum Advance	147
Vacuum Advance Lines	136

Vacuum Check Valve, Brake Booster	185
Vacuum Hose	136
Vacuum Line Components	136
Vacuum Modulator Lines	175
Vacuum Operated Door Lock Components	69
Valley Pan.....	138
Valve Cover Plugs.....	122
Valve Covers.....	121
Valve Spring Sets	155
Valvetrain Components	154
Vanity Mirrors.....	44
Vapor Canister & Filter	130
Vent Window Cranks	66-67
Vent Window Latches.....	75
Vinyl Harness Wrap.....	116
Vinyl Tops.....	86
Vinyl Yardage	14
Visors and Components.....	44
Voltage Regulators	114

-W-

Water Blades.....	6
Waternecks.....	139-140
Water Pumps	140
Water Pump Divider Plates.....	141
Weatherstrips:	
Adhesive	96
Convertible Top.....	86
Door	72
Door Hinge "J"	74
Glass Channel	71
Hood to Cowl.....	58
Lock Pillar.....	91
Pillar Post.....	86
Roof Rail.....	70
Sash Channel.....	72
Trunk	96
Vent Window	74
Rear 1/4 Window	89-90
Wheel Bearings & Seals.....	197
Wheel Components	210-214
Wheel Cylinders	194
Wheelhouse Panels - Inner	92
Wheel Paints.....	210,212
Wheel Seals.....	197
Wheel Sets.....	212
Wheelwell Moldings:	
Front	56
Windage Tray	153
Window Frames:	
Door	73
Rear 1/4 Window	90
Vent Window	75
Window Guides	70,71
Window Lace	45
Window Motors.....	68,89
Window Regulators	6
Window Regulator Handles	66-67,88
Window Rollers.....	67,89
Window Setting Channel.....	90
Window Stop Kits	64
Windshield Channels	79-80
Windshield Washer Components.....	169-170
Windshield Washer Nozzles	169
Windshield Wiper Blades	81
Windshield Wiper Components	80-81
Windshield Wiper Motors	81
Windshield Moldings.....	78
Wire Loom.....	116
Wire Retainers	149
Wiring Harnesses	117-119
Wiring Harness Gutter	169
Wiring Harness Grommet.....	92
Wiring Harness Straps & Retainers	159

SHOP ONLINE AT WWW.AMESPERF.COM

Home
About Us
Free Catalog
Parts Search
Place Order!
Order Help
Show Dates
Nationals
Download
New Products
Cars Wanted
News
Tech Help
Cool Links
Tracking
Clubs

800-421-AMES

Mon Jun 08
2009 08:18:55
GMT-0400
(EDT).

Ames Performance Engineering
Nation's Largest Supplier of Classic Pontiac Parts

Pontiac Owners
GET A FREE
PONTIAC PARTS CATALOG
1967-81 Firebird
Trans Am
1964-77
GTO
LeMans
1955-77
Fullsize
Grand Prix

or Call
1-800-421-2637

ORDER ONLINE
Over 18,000 (click here)
Ames Part Numbers
4 Search Methods
Find the Parts you need, FAST!

Ames Performance
Logo T-Shirts

New Products

Download
Click Here to Download
Our Latest Catalogs
In .pdf Format

Ames Performance
Tel Power
Pontiac Nationals

WHY ORDER FROM AMES ON THE INTERNET?

- All GTO, Firebird and Full-size available.
- All 20,000+ Ames part #'s available.
- 24 hour 365 days/year service.
- Completely secure website.
- No phone machines.
- No time lost on hold.
- No busy signals.
- No inter-office phone transfers.

<http://www.amesperf.com>

GTO OWNERS!

Our NEW GTO, LeMans, Tempest catalog is available!

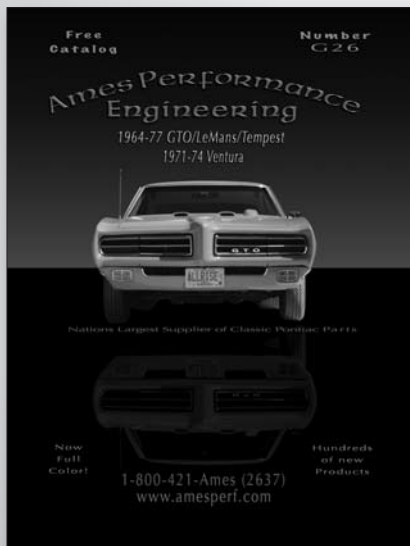

REQUEST THE "GTO CATALOG"

BIRD LOVERS!

Ask for the newest Firebird/Formula/Tran Am Catalog



REQUEST THE "FIREBIRD CATALOG"

APPROXIMATE DELIVERY TIME TO YOUR AREA

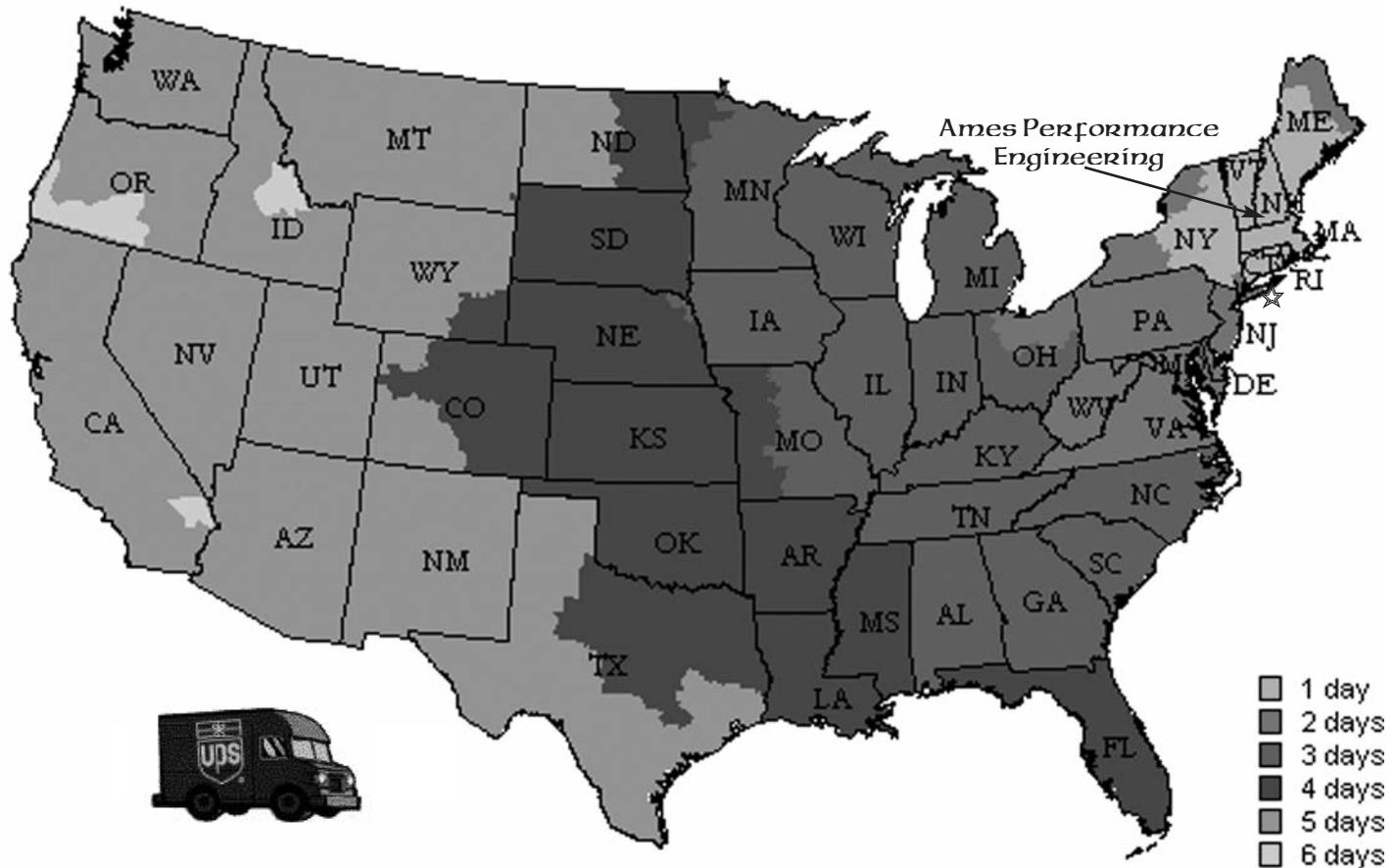

Although we stock most items in this catalog and ship most orders within 24 hours, you should factor in delivery time as well. Above are approximate ground shipping times to your area. Please call for delivery time estimate for locations outside the continental US.

Please note that these approximate times do not apply to truck freight orders.

Next Day, 2nd Day, and 3-Day shipping are also available upon request at an additional charge.

When in doubt . . . Document it!

PHS Automotive Services "PHS" Documentation

As many classic Pontiac owners are aware, it is now possible to authenticate the originality of 1961-99 Pontiacs. An independent firm has been authorized by Pontiac Motor Division to fill the increasing demand for historic information from Pontiac owners, restorers, collectors, enthusiasts and buffs who are looking for specific information on their Pontiac. PHS Automotive Services is comprised of Pontiac enthusiasts who are extremely knowledgeable and capable of handling your requests. With the value of Pontiac cars escalating rapidly, this service is not only informational but can enhance the value of your classic. We highly recommend PHS Automotive Services and their product.

There are now 2 ways to order your information packet.

<http://www.phs-online.com>

phs@phs-online.com

By Mail

Send Your VIN#, Name, Address, Phone Number, Check or Credit Card Number (MC or Visa) and Expiration Date to:

PHS Automotive Services P.O. Box 183251
Shelby Township, MI 48318
1-586-781-5164

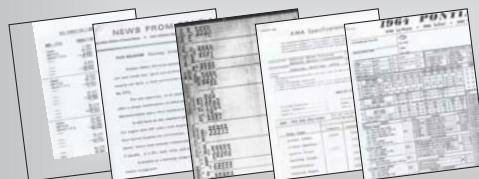

By Fax

Fax Your VIN#, Name, Address, Phone Number, Credit Card Number (MC or Visa) and Expiration Date to:
1-586-781-5167 (orders only please)

\$50.00 packet to be sent by mail - US Orders Only
\$65.00 packet to be sent back to you by fax (reply the next business day) - US Orders Only

\$60.00 packet to be sent by mail - Foreign Orders
\$75.00 packet to be sent back to you by fax (reply the next business day) - Foreign Orders

The information packet from PHS Automotive Services will include:

- A copy of the factory invoice or billing history.
- A letter decoding the options (where necessary).
- A copy of a dealer order form for that year.